

TRS

TWIN PROFILE RAIL STAGE

STROKE CONFIGURABLE ACTUATOR



TRS165STD

TRS100C2C
(C2C: Carrier to Carrier)

TRS100STD

**ENCLOSED DESIGN
PROFIED RAIL ACTUATOR**

LINEAR SOLUTIONS MADE EASY

TRS Twin Rail Stage Actuator

TRS: A Rugged, Accurate Stage

The TRS is a highly capable stage product and is the perfect for a base in multi-axis systems. The machined, rigid design handles high moment loading while providing reliable positioning along the length of travel.



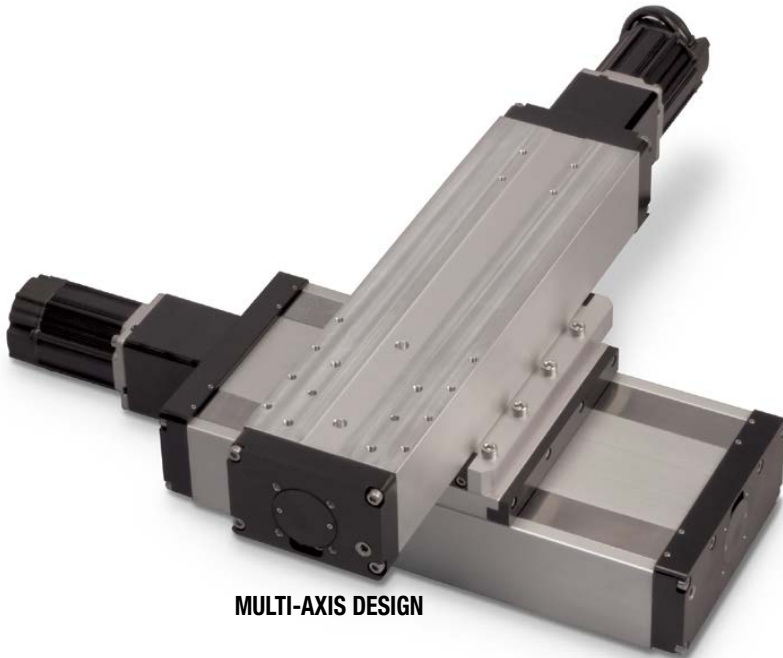

Maximum flexibility is achieved through stroke configurable design, ensuring the right stroke length can be selected to minimize footprint. Online CAD and Sizing tools enable rapid design iterations throughout the design process.

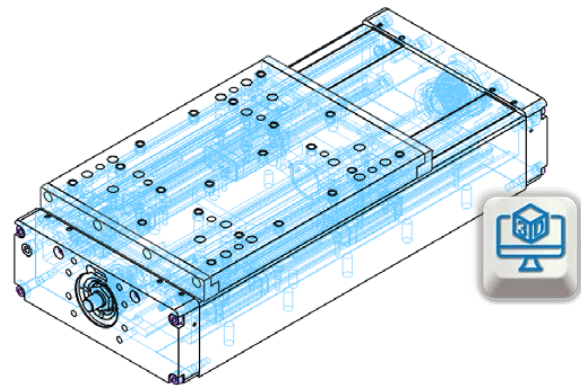
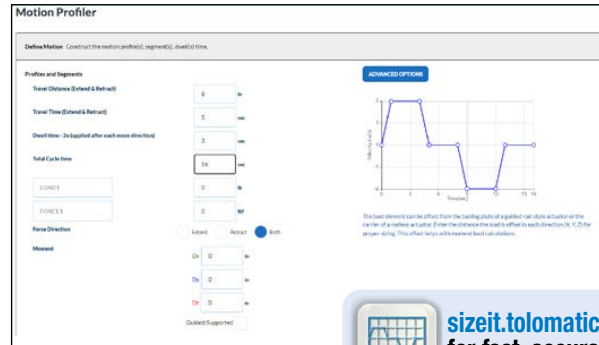

MULTI-AXIS DESIGN



A Comparison of Screw Drive Actuators

	TRS	B3S	MXE-S	MXE-P
				
Features:	Superior rigidity, high moment load capacities	Internal bearing, highest load and bending moments	Basic guidance and support	High load and bending moment capacities
Load up to: <i>(with options)</i>	1,356 lb [615 kg]	8,000 lb [3,629 kg]	1,040 lb [472 kg]	2,584 lb [1,172 kg]
Thrust up to:	562 lbf [2.5 kN]	2,700 lbf [12 kN]	4,300 lbf [19.1 kN]	4,300 lbf 19.1 kN]
Speed up to:	36 in/sec [910 mm/sec]	60 in/sec [1,500 mm/sec]	60 in/sec [1,500 mm/sec]	60 in/sec [1,500 mm/sec]
Stroke Length up to:	43 in [1,090 mm]	179 in [4,550 mm]	179 in [4,550 mm]	179 in [4,550 mm]
Screw/Nut Type	Ball & Roller	Solid & Ball	Solid & Ball	Solid & Ball
www.tolomatic.com for complete information, search by literature number:				
Literature Number:	3600-4222	3600-4176	8300-4000	8300-4000

(Not all models deliver ALL maximum values listed, i.e.: Maximum thrust may not be available with maximum speed)

TRS Twin Rail Stage Actuator

Storage & Retrieval

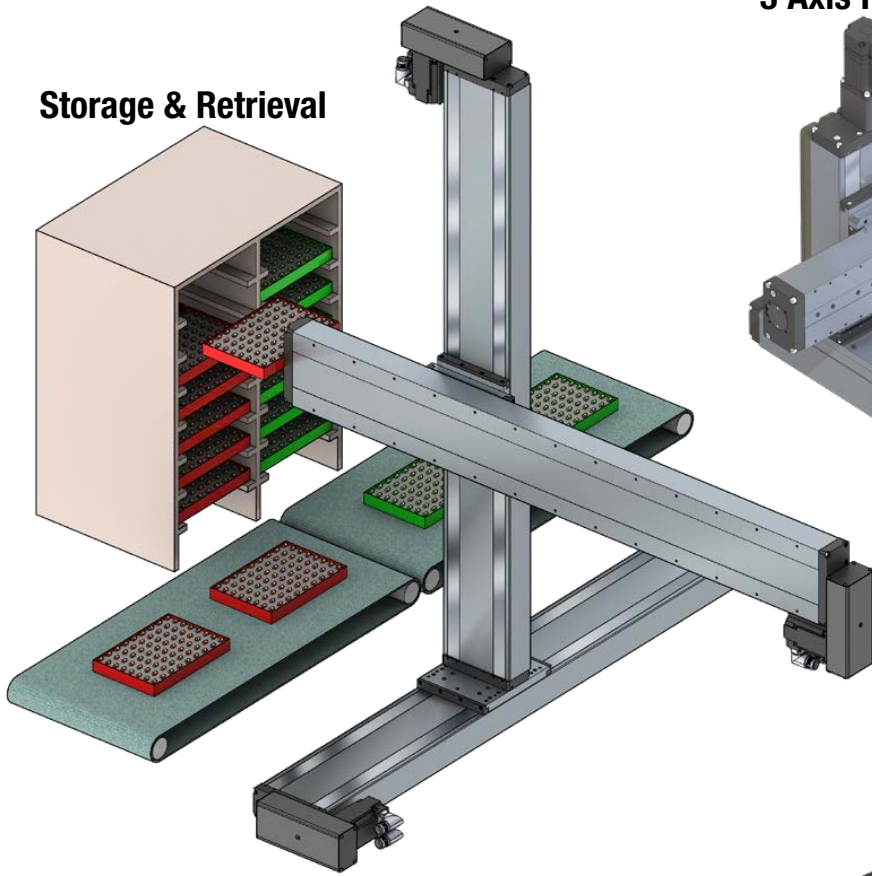

3 Axis Positioning

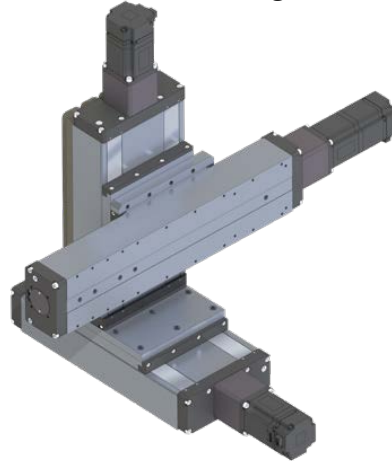

CONTENTS

Rodless ComparisonTRS_2

Applications.....TRS_3

TRS FeaturesTRS_3

TRS SpecificationsTRS_6

TRS Dimensions.....TRS_11

SwitchesTRS_13

Application Data
Worksheet.....TRS_17

Selection Guidelines ...TRS_18

TRS OrderingTRS_19

Other Tolomatic
Products.....TRS_20

Robot Arm Positioning

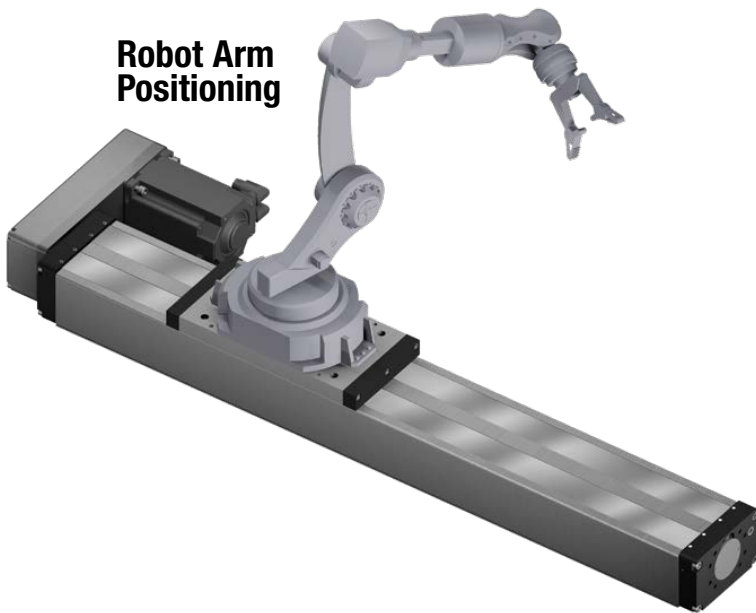

Laser Engraving

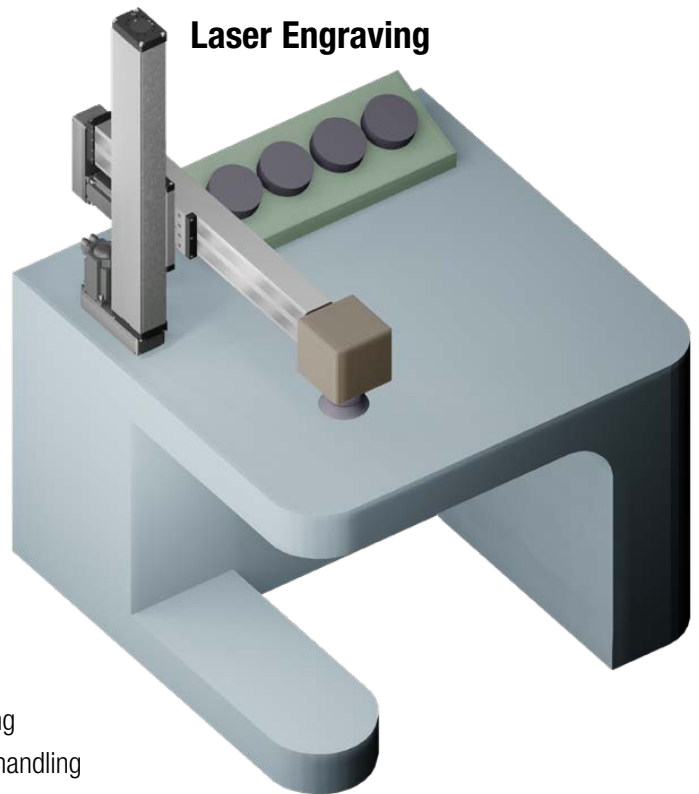

- Inspection and measurement
- Medical equipment
- Pick and place
- Precision grinders
- Stage motion control
- Table positioning
- Test stands
- Machine centers
- Machine tools
- Drilling
- Cutting
- Positioning
- Material handling systems
- Pick and place
- X Y Z axis (2 and 3 axis configurations)

TWIN RAIL STAGE ENCLOSED DESIGN PROFILED RAIL ACTUATOR

ENDURANCE TECHNOLOGYSM

A Tolomatic Design Principle

REDUCE UNPLANNED DOWNTIME: Endurance Technology features are designed for maximum durability to provide extended service life.

The TRS Twin profile rail stage with enclosed design is built from the ground up to be highly rigid and accurate. Available in 100 and 165 sizes and capable of handling loads up to 1,356 lb (615 kg). To maximize design flexibility, the TRS actuator is stroke configurable to minimize overall machine footprint.

CARRIER TO CARRIER MOUNTING

- Build a multi-axis system with reduced components by leveraging this standard mounting option
- Tolomatic representatives are available to assist with the sizing

HIGH RIGIDITY

Twin rails each with 2 bearings minimizes deflection for reliable and accurate positioning along the length of travel

MULTIPLE SCREW TECHNOLOGIES

ROLLER NUT

Roller nuts provide the highest thrust and life ratings available



BALL NUT

Ball nuts offer efficiency at a cost effective price



SCREW ACCURACY

$\pm 0.0102\text{mm}/300\text{mm}; \pm 0.0004\text{"/ft.}$

SCREW ACCURACY

$\pm 0.051\text{mm}/300\text{mm}; \pm 0.002\text{"/ft.}$

BREATHER/PURGE PORTS

Positive pressure with air lines and filters helps reduce contamination of the interior of the actuator

IP44 RATED WITH STAINLESS STEEL DUST BANDS

- Perfect for industrial environments
- Limits the amount of contaminants that enter the actuator, which protects components for reduced maintenance and increased uptime

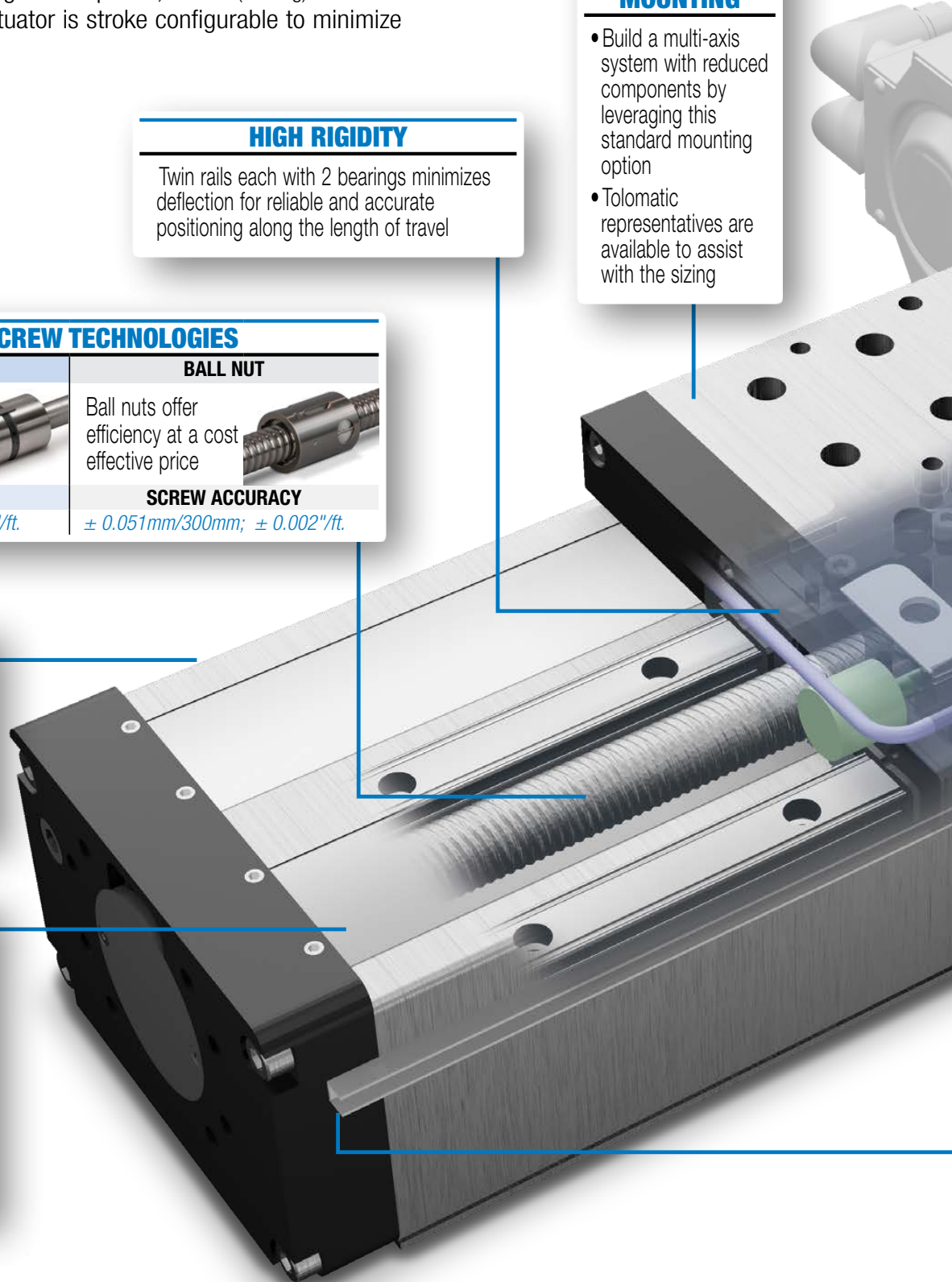

YOUR MOTOR HERE

- For maximum design flexibility, specify the motor or gearbox to be installed with in-line or reverse parallel mounting.
- For out of the box installation, the TRS actuator ships with the proper mounting hardware

STANDARD MOUNTING FEATURES

- **Threaded mounting holes:** Evenly spaced along the base of the actuator
- **Dowel pin holes:** Ensures the actuator can be aligned without additional modification

CLEAN SMOOTH DESIGN

- Smooth and flat surface to create the cleanest sealing design in the industry
- Wiper and seal are integrated in carrier design to enable clean and smooth operation

OPTIONAL TOE CLAMP MOUNTING

Slot and clamps provide convenient mounting option for fast installation



OPTIONAL SWITCH WITH RAIL

- 12 switch choices in normally open or closed; with flying leads or quick-disconnect



- Easily adjust the location of switches along the length of the actuator

TRS Twin Rail Stage Actuator



BENDING MOMENTS

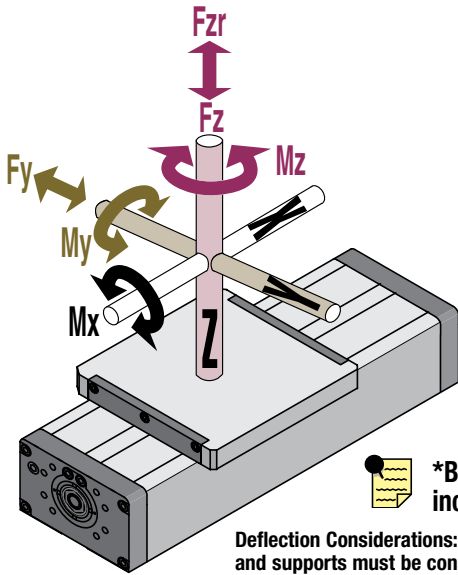

MAX. BENDING MOMENTS AND LOADS*					
		Metric		U.S. Conventional	
Max. Bending Moments		100	165	100	165
Mx (Roll)	N-m	101	294	lb-in	895, 2,604
My (Pitch)	N-m	194	284	lb-in	1,718, 2,512
Mz (Yaw)	N-m	175	256	lb-in	1,551, 2,269
Max. Loads					
Fz (Radial)	kg	492	615	lb	1,085, 1,356
Fzr (Reverse Radial)	kg	421	526	lb	928, 1,160
Fy (Lateral)	kg	380	475	lb	838, 1,048

*Bending moments & load specifications are based on (5,000 kM) 200,000,000 linear inches of carrier travel.

Deflection Considerations: In applications where substantial Mx or My moments come into play, deflection of the actuator frame, carrier and supports must be considered. The deflection values shown in the Load Deflection charts, are based on actuator mounted with its base fully restrained to a surface.

LOAD DEFLECTION

DEFLECTION ABOUT THE Y-AXIS

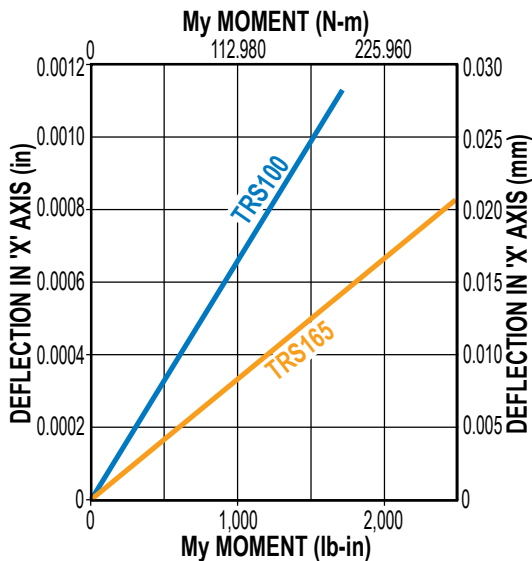
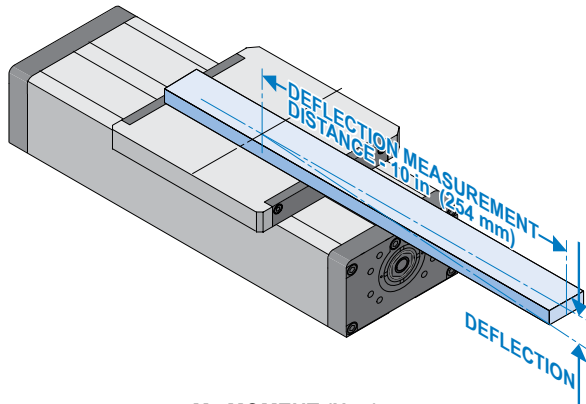

DEFLECTION ABOUT THE X-AXIS

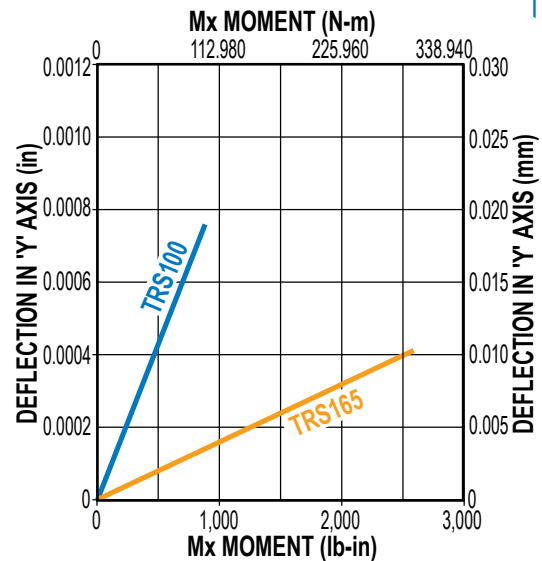
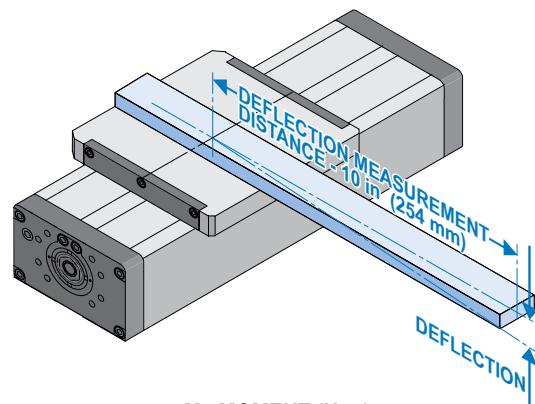

TRS Twin Rail Stage Actuator



TRS SPECIFICATIONS

SPECIFICATIONS RELATED TO ACTUATOR SIZE AND SCREW SELECTION

TRS LEAD SCREWS METRIC											
ACTUATOR	SCREW CODE	LEAD (mm)	MOTOR CONFIG	LEAD ACCURACY (mm/300)	BACKLASH (mm)	MAXIMUM THRUST (N)	MAXIMUM STROKE (mm)	INERTIA			DYNAMIC FRICTION TORQUE (N-m)
								BASE ACTUATOR		PER/in OF STROKE (kg-m ² x 10 ⁻⁶)	
								In Line (kg-m ² x 10 ⁻⁶)	Rev. Parallel (kg-m ² x 10 ⁻⁶)		
TRS100	BNM05	5	BOTH	0.100	0.07 - 0.12	2,500	750	40.82	135.32	1.29	0.18
	BNM10	10	BOTH	0.100	0.07 - 0.12	2,500	750	45.35	139.85	1.29	0.19
TRS165	BNM05	5	BOTH	0.100	0.07 - 0.12	2,500	1,100	40.67	135.17	1.29	0.18
	BNM10	10	BOTH	0.100	0.07 - 0.12	2,500	1,100	43.30	137.80	1.29	0.19
	RN05	5	LMI	0.010	0.03	2,500	575	38.48	—	0.99	0.21
	RN05	5	RP	0.010	0.03	2,500	557	—	132.98	0.99	0.23
	RN10	10	LMI	0.010	0.03	2,500	575	41.67	—	0.99	0.21
	RN10	10	RP	0.010	0.03	2,500	557	—	136.16	0.99	0.23

TRS LEAD SCREWS U.S. CONVENTIONAL											
ACTUATOR	SCREW CODE	LEAD (mm)	MOTOR CONFIG	LEAD ACCURACY (in/ft)	BACKLASH (in)	MAXIMUM THRUST (lbf)	MAXIMUM STROKE (in)	INERTIA			DYNAMIC FRICTION TORQUE (lb-in)
								BASE ACTUATOR		PER/in OF STROKE (lb-in ²)	
								In Line (lb-in ²)	Rev. Parallel (lb-in ²)		
TRS100	BNM05	5	BOTH	0.004	0.0028 - 0.0050	562	29.5	0.1397	0.4631	0.0044	1.56
	BNM10	10	BOTH	0.004	0.0028 - 0.0050	562	29.5	0.1552	0.4786	0.0044	1.69
TRS165	BNM05	5	BOTH	0.004	0.0028 - 0.0050	562	43.3	0.1392	0.4626	0.0044	1.56
	BNM10	10	BOTH	0.004	0.0028 - 0.0050	562	43.3	0.1482	0.4716	0.0044	1.69
	RN05	5	LMI	0.0004	0.0012	562	22.6	0.1317	—	0.0034	1.88
	RN05	5	RP	0.0004	0.0012	562	21.9	—	0.4551	0.0034	2.00
	RN10	10	LMI	0.0004	0.0012	562	22.6	0.1426	—	0.0034	1.88
	RN10	10	RP	0.0004	0.0012	562	21.9	—	0.466	0.0034	2.00

SCREW TYPE DESCRIPTION
 RN Roller Nut
 BN Ball Nut

Contact the factory for higher accuracy and lower backlash options.

TRS CARRIER TO CARRIER MAX. LOAD

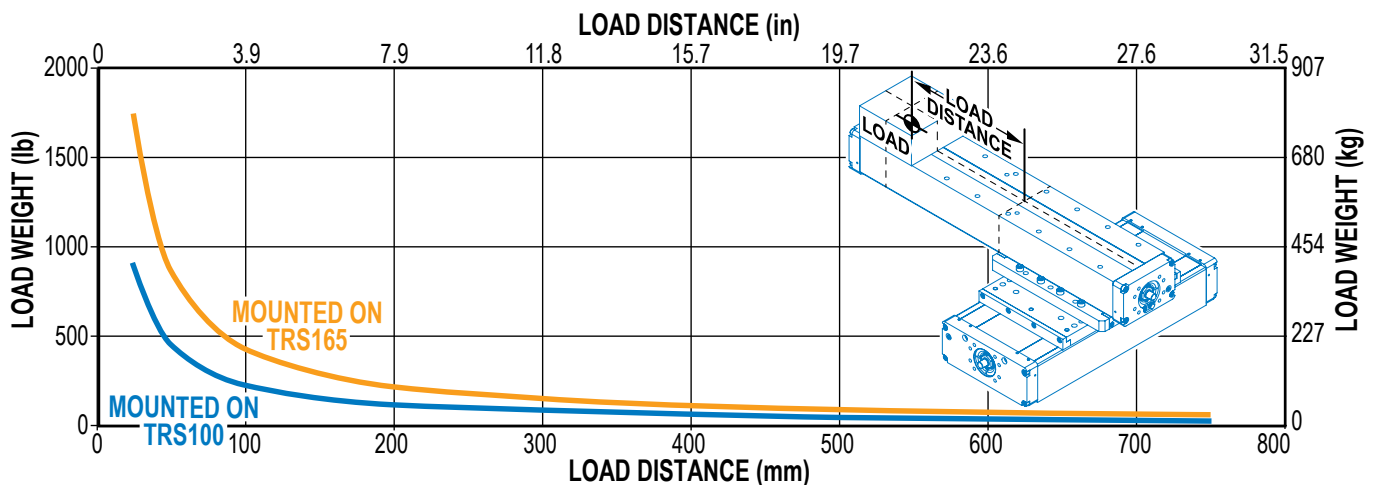

TRS Twin Rail Stage Actuator



ACTUATOR SPECIFICATIONS

		TRS100		TRS165			
		Ball Nut		Ball Nut		Roller Nut	
		LMI	RP	LMI	RP	LMI	RP
Carrier Assembly Weight	kg	2.16	2.16	3.20	3.20	3.55	3.55
Base Weight (incl. carrier)	kg	5.97	7.79	8.44	10.26	8.74	10.56
Weight per unit of stroke	kg/mm	0.010	0.010	0.015	0.015	0.014	0.014
Carrier Assembly Weight	lb	4.75	4.75	7.06	7.06	7.82	7.82
Base Weight (incl. carrier)	lb	13.17	17.18	18.61	22.62	19.28	23.29
Weight per unit of stroke	lb/in	0.56	0.56	0.81	0.81	0.80	0.80
Temperature Range	4-54 °C; 40-130 °F						

FRICTION FORCE

$$N = 0.003 \times \text{LOAD (kg)} + 17.6$$

$$\text{lbf} = 0.0003 \times \text{LOAD (lb)} + 3.96$$

STRAIGHTNESS AND FLATNESS

Length of Travel	mm	60	120	180	240	300	360	420	480	540	600	660	720	780	840	900	960	1,020	1,080	1,100
	in	2.4	4.7	7.1	9.5	11.8	14.2	16.5	18.9	21.3	23.6	26.0	28.4	30.7	33.1	35.4	37.8	40.2	42.5	43.3
Straightness/Flatness	µm	20	21	22	23	24	26	27	28	29	30	32	33	34	35	36	38	39	40	40



- Listed values are intended for reference purposes only, and not as an engineering standard of absolute tolerance for a given actuator. Reference values are measured in ideal conditions. Actual values in the field may vary due to temperature, mounting surface, or other environmental factors.
- Heat generated by the motor and drive should be taken into consideration as well as linear velocity and work cycle time. For applications that require operation outside of the recommended temperature range, contact the factory.
- An option is available at additional cost to document the straightness and flatness values specific to the actuator, contact the factory prior to ordering.

TRS SUPPORT RECOMMENDATIONS

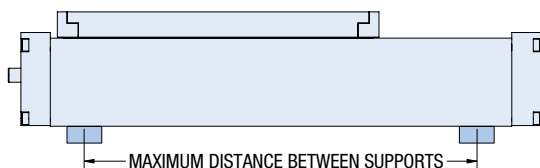
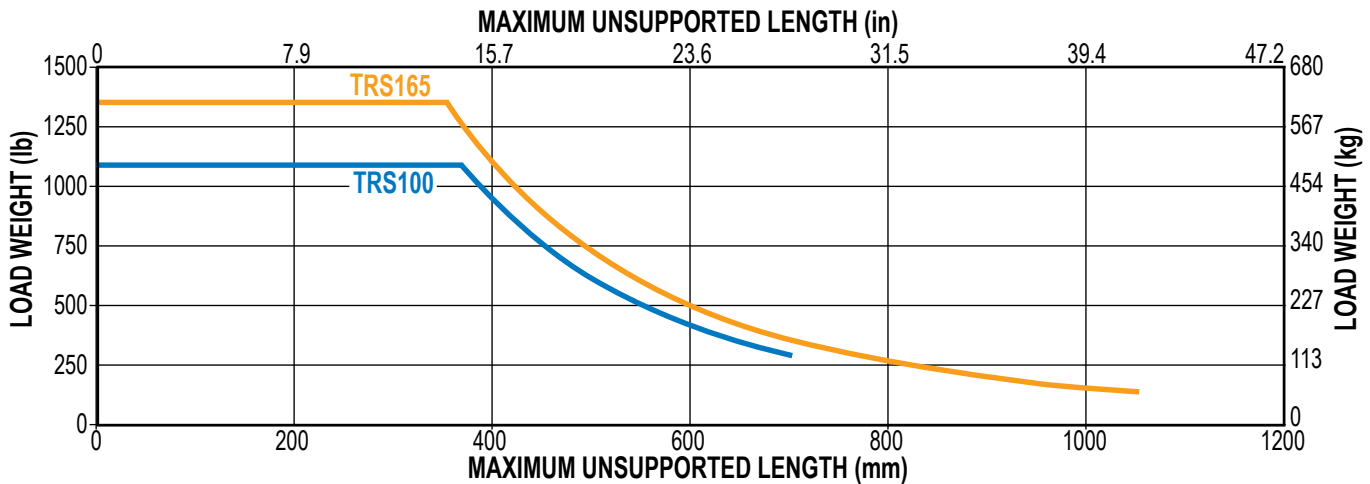

Actuator body theoretical axial deflection will not exceed 0.015 in (0.38mm)

TRS Twin Rail Stage Actuator



SCREW/NUT COMBINATIONS

TRS BALL & ROLLER SCREW CRITICAL SPEED CAPACITIES

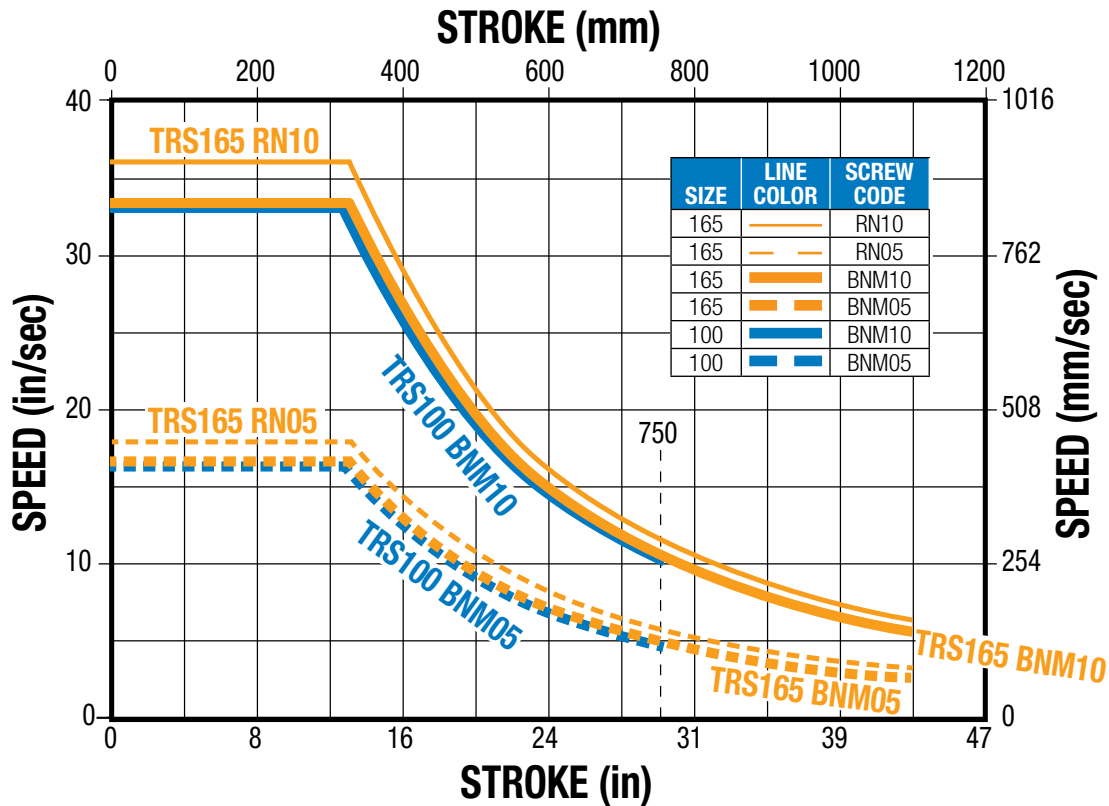

SCREW LIFE CALCULATION

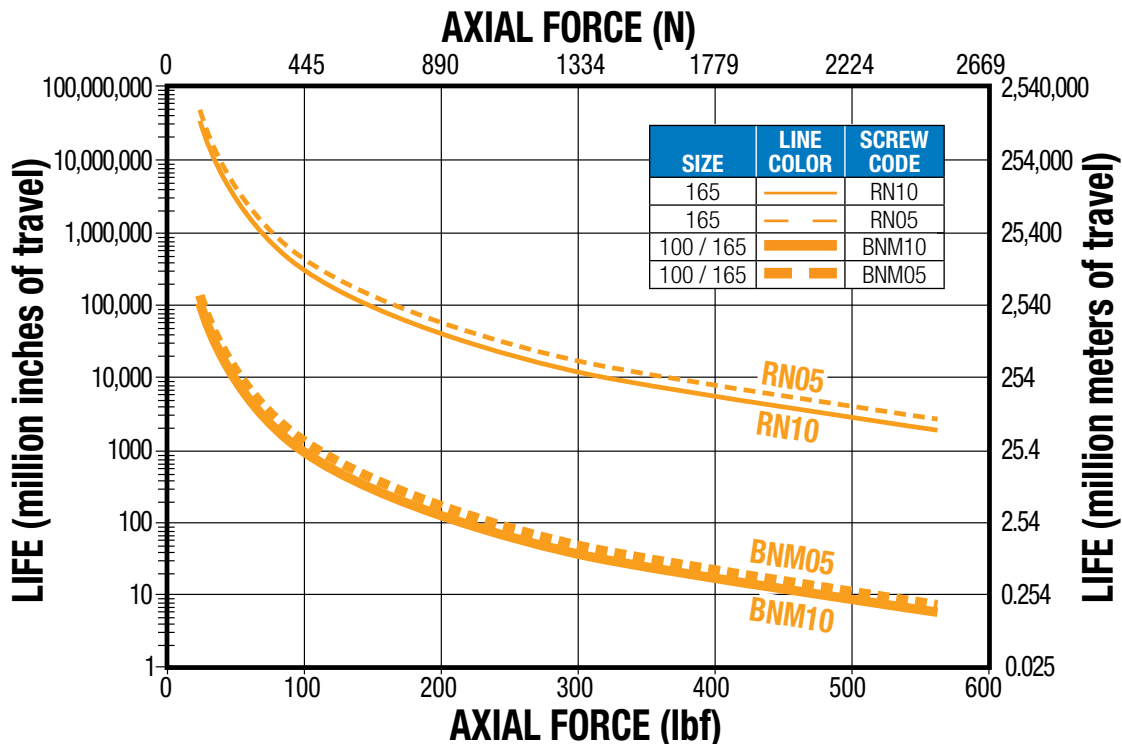

SCREW TYPE DESCRIPTION
 RN Roller Nut
 BN Ball Nut

**Life indicates theoretical maximum life of screw only, under ideal conditions and does not indicate expected life of actuator.

TRS Twin Rail Stage Actuator



DIMENSIONS, Top View

TRS165

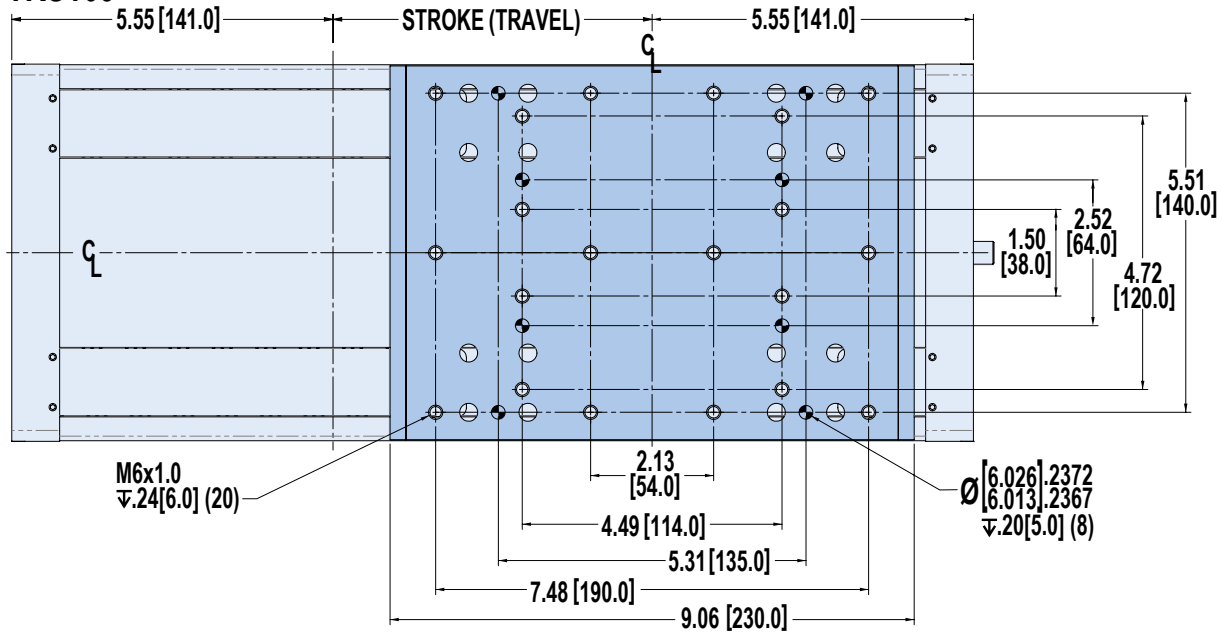

TRS100 C2C

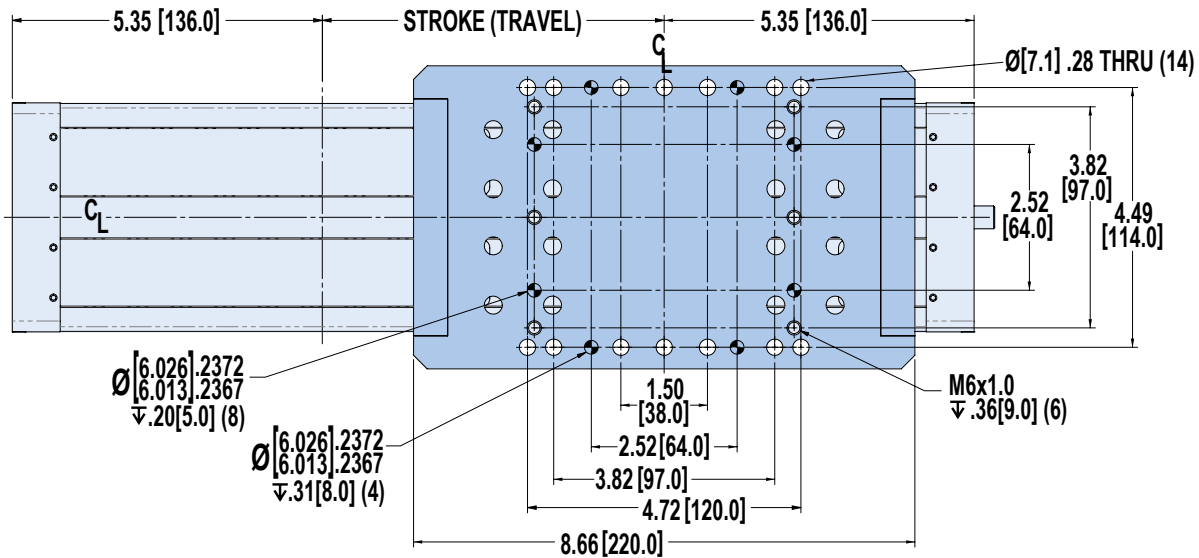

TRS100

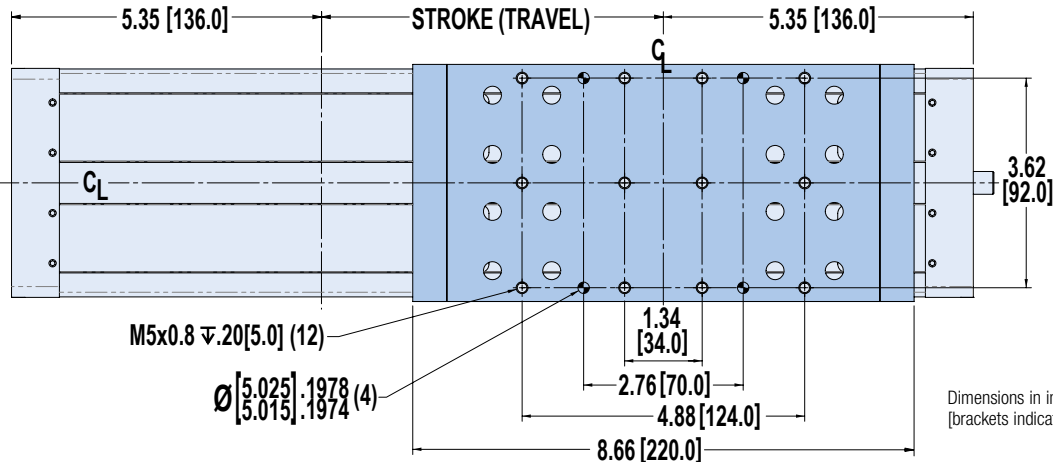

Dimensions in inches
[brackets indicate dimensions in mm]

TRS Twin Rail Stage Actuator

DIMENSIONS, End & Bottom Views



TRS165

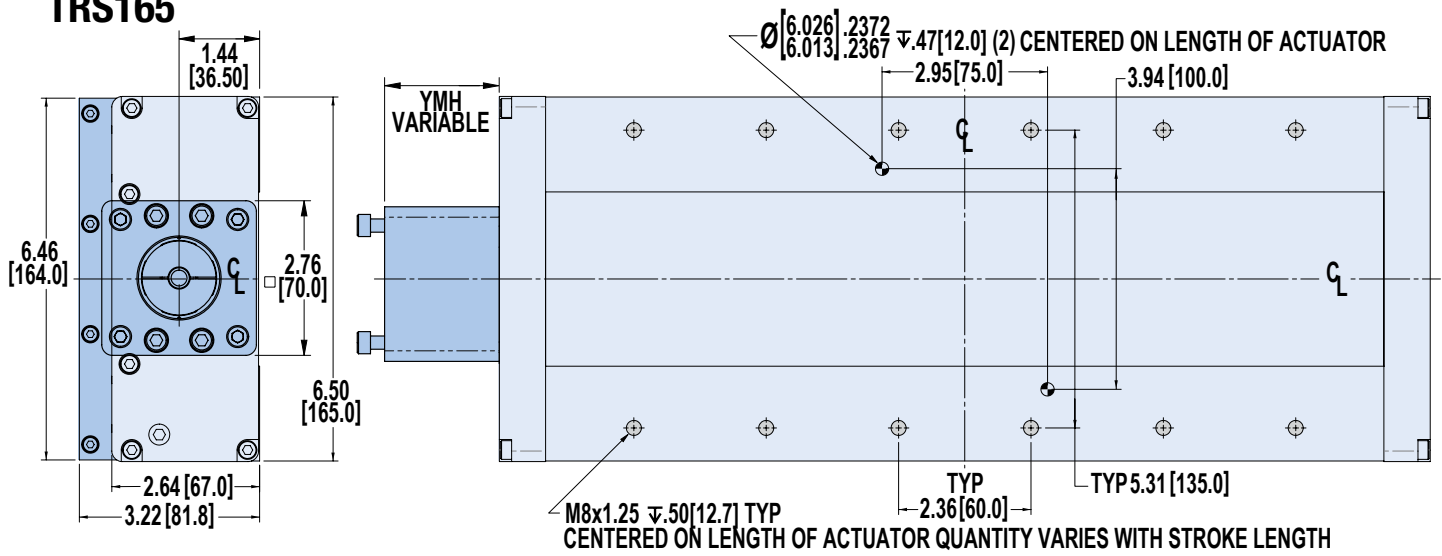

TRS100 C2C

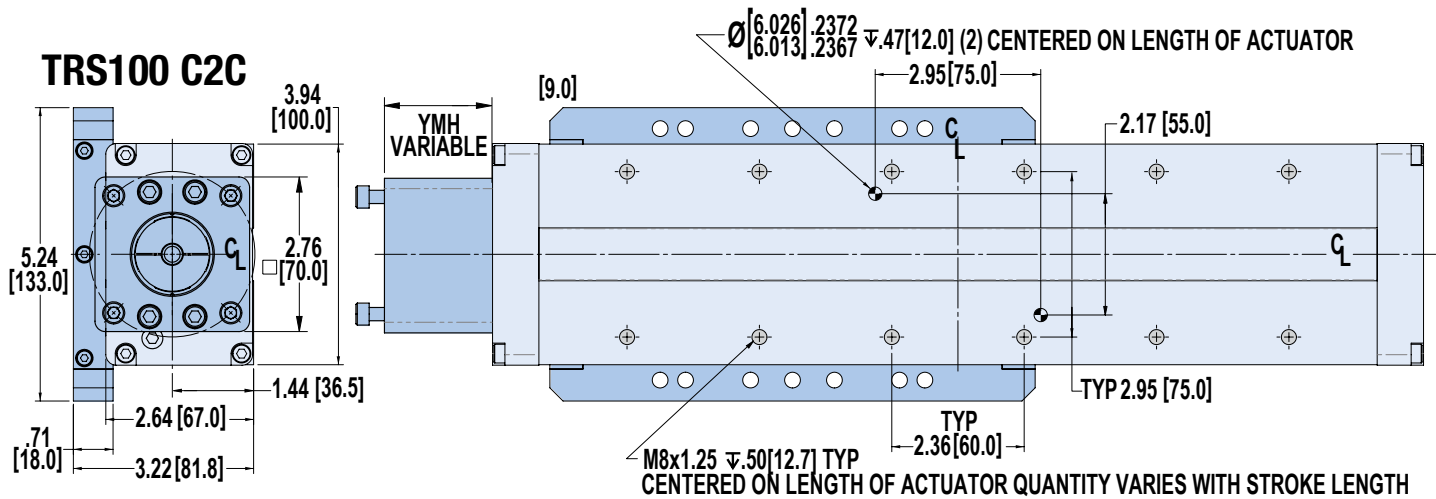

TRS100

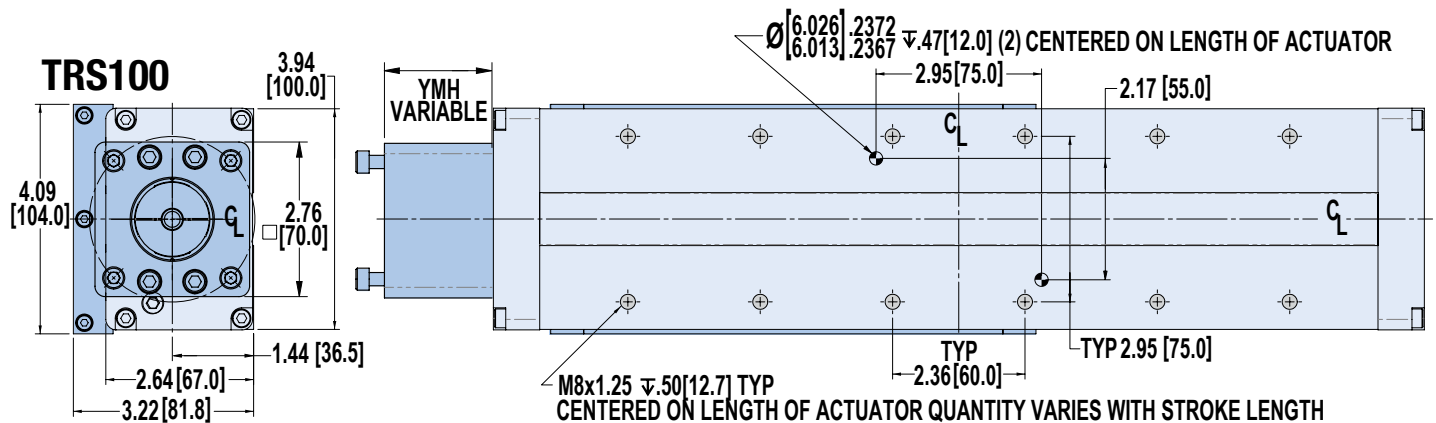

Dimensions in inches [brackets indicate dimensions in mm]

TRS Twin Rail Stage Actuator

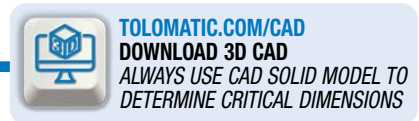

DIMENSIONS: Toe Clamps

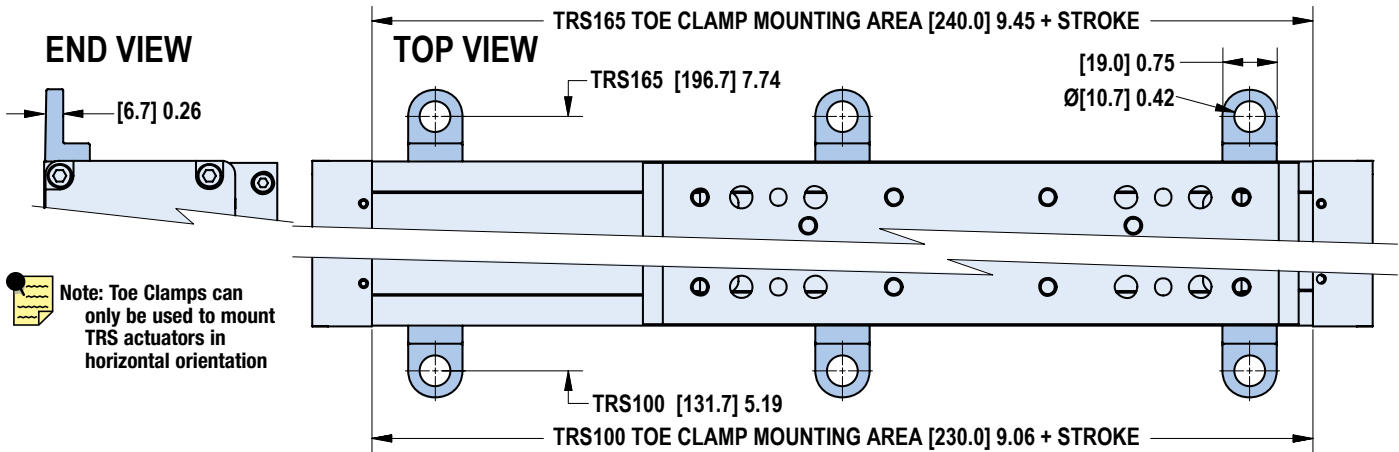

Note: Toe Clamps can only be used to mount TRS actuators in horizontal orientation

DIMENSIONS: Switch Rail

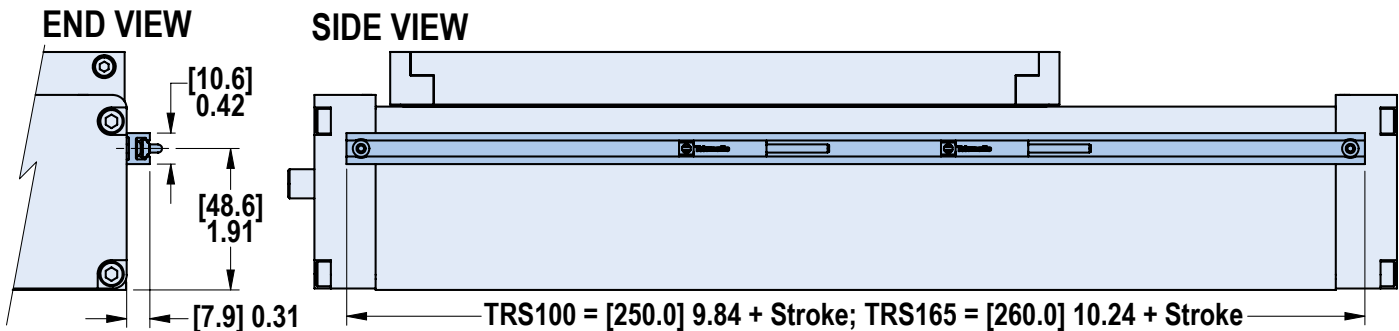

Note: Switch rail is installed on the right side of the actuator (from the motor end) for all motor mounting configurations except RPR1 where it is installed on the left side of the actuator.

DIMENSIONS: No Motor Mount (threaded holes and bolt circle; when no motor mount is selected)

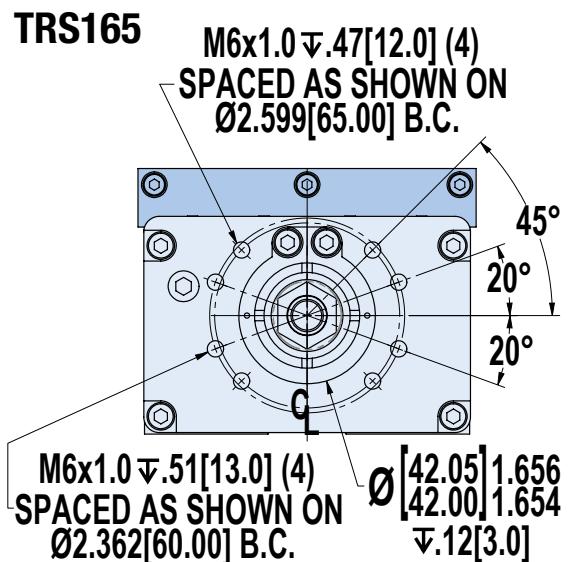
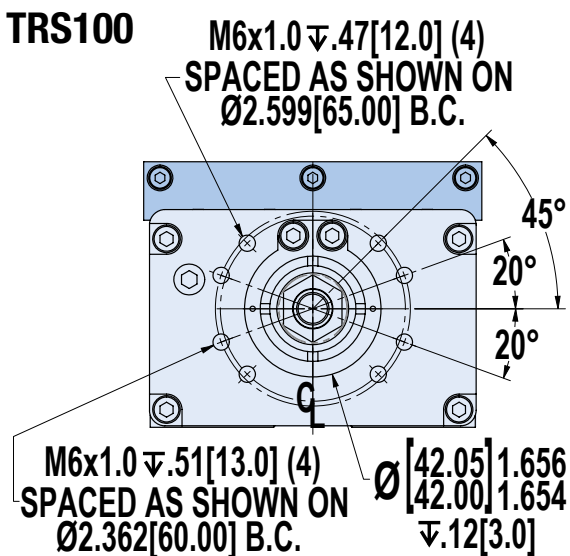

Dimensions in inches [brackets indicate dimensions in mm]

TRS Twin Rail Stage Actuator

DIMENSIONS: RP Motor Mounts: TRS100

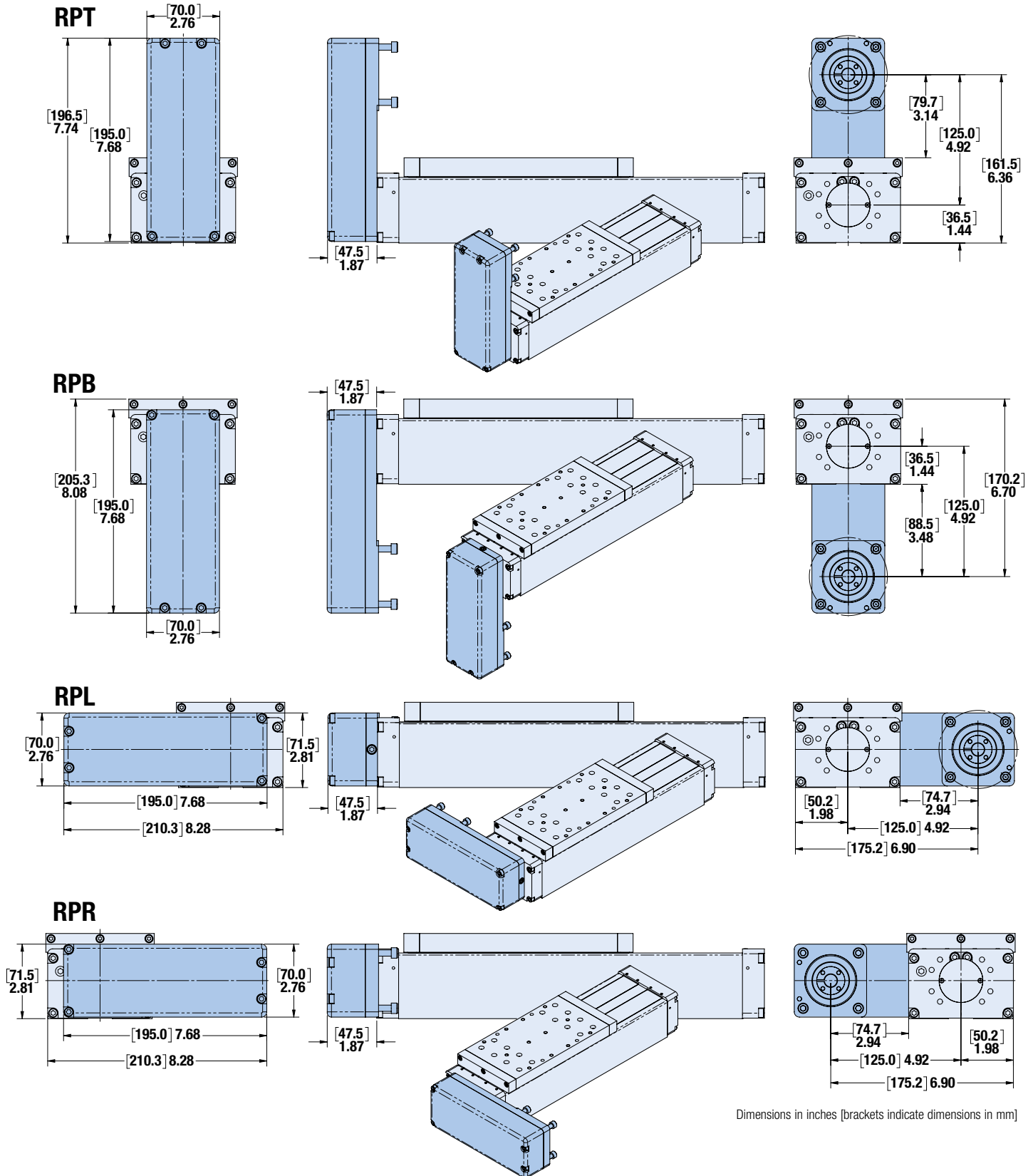

Dimensions in inches [brackets indicate dimensions in mm]



***LARGE FRAME MOTORS AND SMALLER SIZE ACTUATORS:** Cantilevered motors need to be supported, if subjected to continuous rapid reversing duty and/or under dynamic conditions.

TRS Twin Rail Stage Actuator



DIMENSIONS: RP Motor Mounts: TRS165

RPT

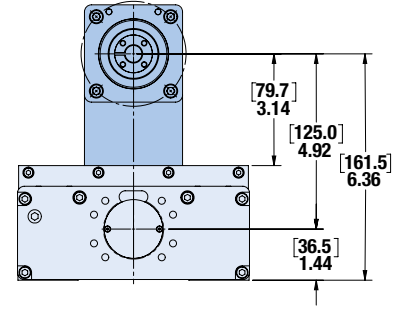
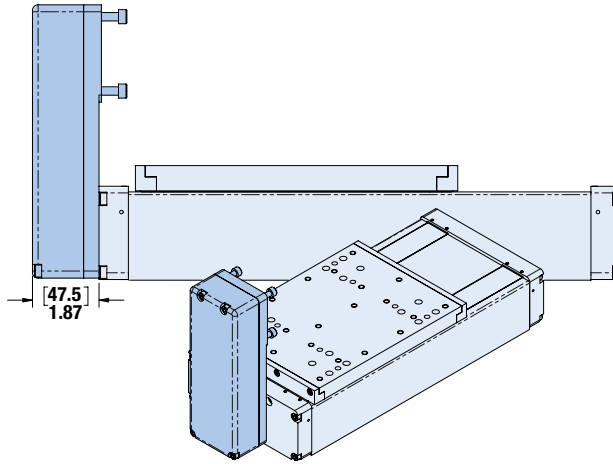
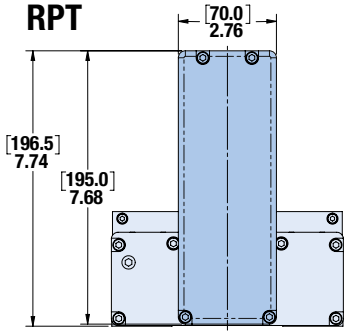

RPB

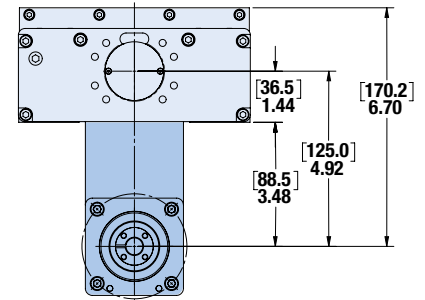
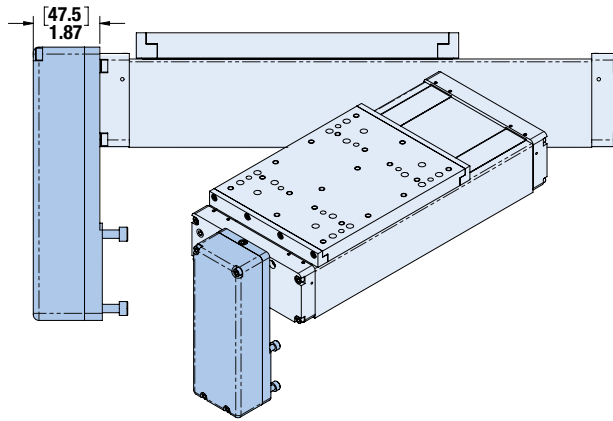
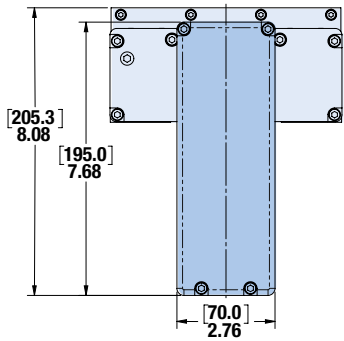

RPL

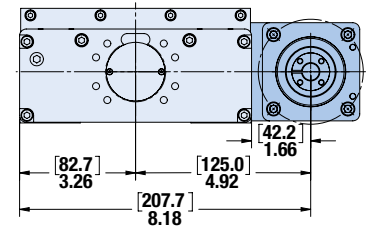
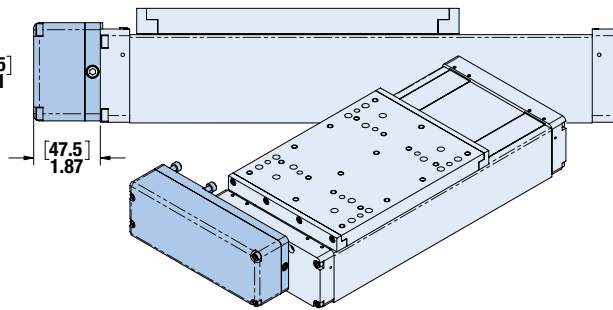
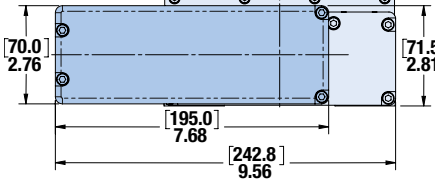

RPR

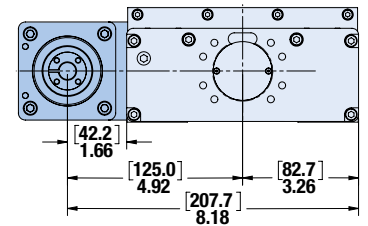
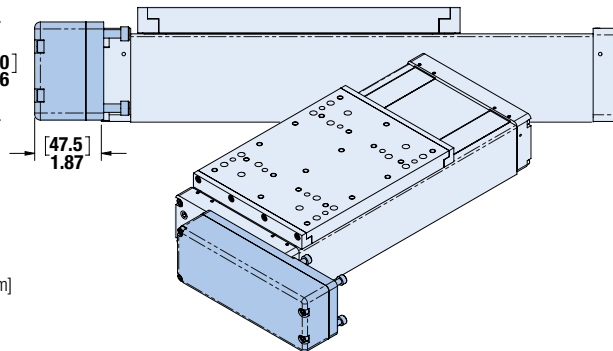
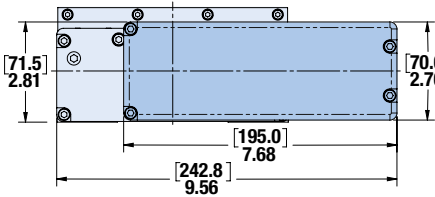

Dimensions in inches [brackets indicate dimensions in mm]



*LARGE FRAME MOTORS AND SMALLER SIZE ACTUATORS: Cantilevered motors need to be supported, if subjected to continuous rapid reversing duty and/or under dynamic conditions.

TRS Twin Rail Stage Actuator

SWITCHES

SPECIFICATIONS







TRS products offer a wide range of sensing choices. There are 12 switch choices: reed, solid state PNP (sourcing) or solid state NPN (sinking); in normally open or normally closed; with flying leads or quick-disconnect.

Commonly used for end-of-stroke positioning, these switches allow drop-in installation anywhere along the rail on the side of the actuator. The one-piece design includes the retained fastening hardware.

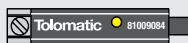
Switches are used to send digital signals to PLC (programmable logic controller), TTL, CMOS circuit or other controller device. Switches contain reverse polarity protection. Solid state QD cables are shielded; shield should be terminated at flying lead end.

All switches are CE rated and are RoHS compliant. Switches feature bright red or yellow LED signal indicators; solid state switches also have green LED power indicators.

	Order Code	Lead	Switching Logic	Power LED	Signal LED	Operating Voltage	**Power Rating (Watts)	Switching Current (mA max.)	Current Consumption	Voltage Drop	Leakage Current	Temp. Range	Shock / Vibration
REED	R Y	5m	SPST Normally Open	—	Red	5 - 240 AC/DC	**10.0	100mA	—	3.0 V max.	—	14 to 158°F [-10 to 70°C]	50 G / 9 G
	R K	QD*											
	N Y	5m	SPST Normally Closed	—	Yellow	5 - 110 AC/DC							
	N K	QD*											
SOLID STATE	T Y	5m	PNP (Sourcing) Normally Open	Green	Yellow	10 - 30 VDC	**3.0	100mA	20 mA @ 24V	2.0 V max.	0.05 mA max.		
	T K	QD*											
	K Y	5m	NPN (Sinking) Normally Open	Green	Red								
	K K	QD*											
	P Y	5m	PNP (Sourcing) Normally Closed	Green	Yellow								
	P K	QD*											
	H Y	5m	NPN (Sinking) Normally Closed	Green	Red								
	H K	QD*											

*QD = Quick-disconnect Enclosure classification IEC 529 IP67 (NEMA 6) CABLES: Robotic grade, oil resistant polyurethane jacket, PVC insulation

⚠️WARNING:** Do not exceed power rating (Watt = Voltage x Amperage). Permanent damage to sensor will occur.

TRS Twin Rail Stage Actuator

WIRING DIAGRAMS

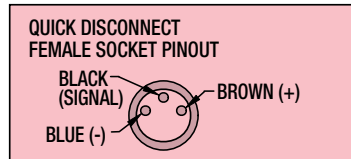
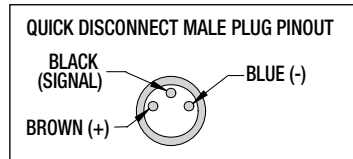
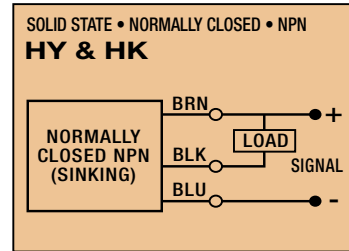
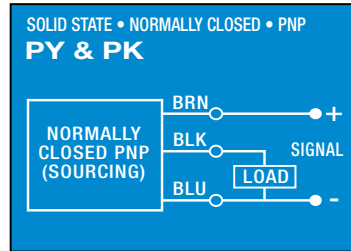
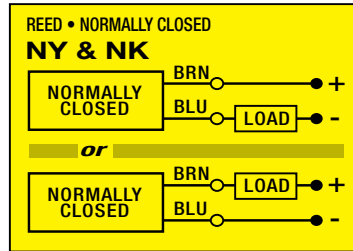
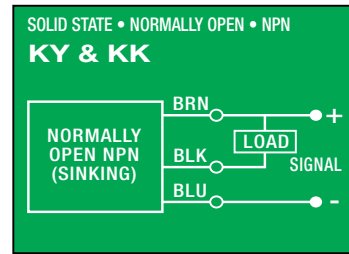
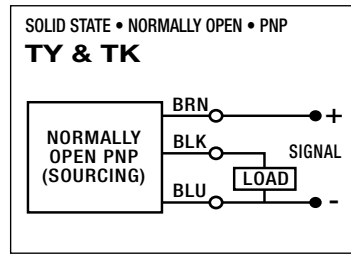
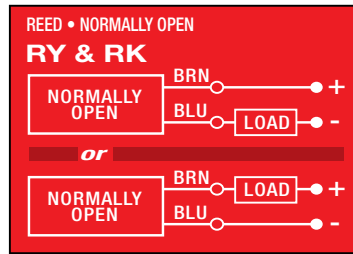

SWITCH INSTALLATION AND REPLACEMENT

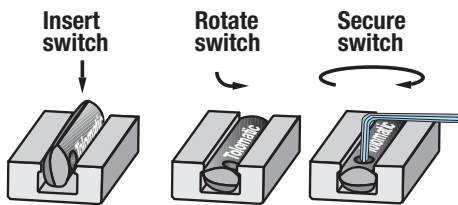

Place switch in side groove on tube at desired location with "Tolomatic" facing outward. While applying light pressure to the switch, rotate the switch halfway into the groove. Maintaining light pressure, rotate the switch in the opposite direction until it is fully inside the groove with "Tolomatic" visible. Re-position the switch to the exact location and lock the switch securely into place by tightening the screw on the switch.

SWITCH DIMENSIONS

Y - direct connect

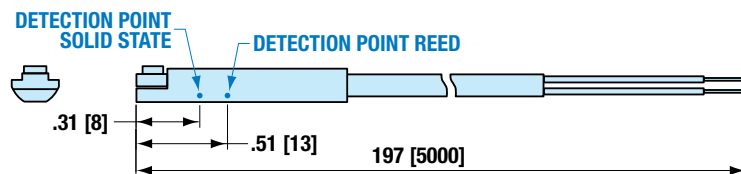

X - QD (Quick-disconnect) switch

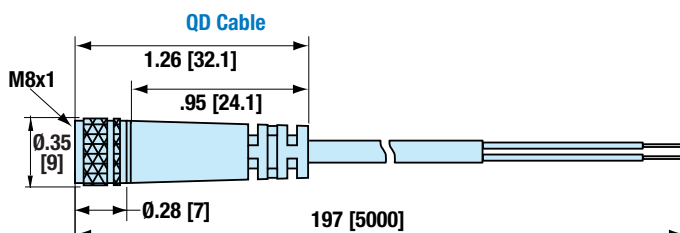
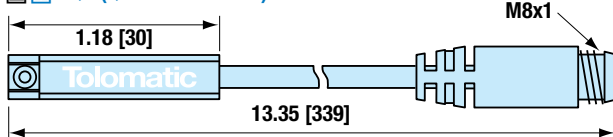

See Page 12 for Switch Rail Dimensions

Dimensions in inches [brackets indicate dimensions in millimeters]

COMPILE APPLICATION REQUIREMENTS

APPLICATION DATA WORKSHEET

Fill in known data. Not all information is required for all applications

ORIENTATION

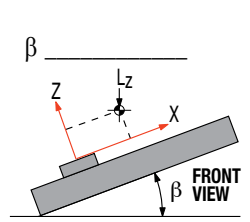
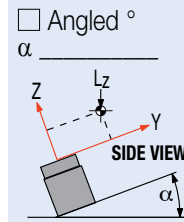
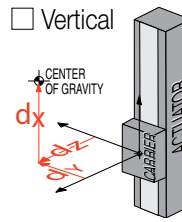
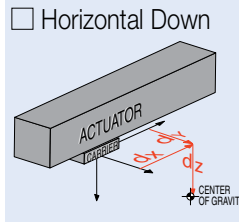
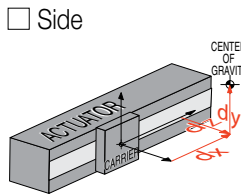
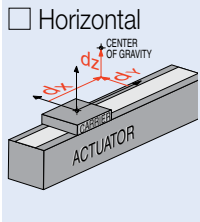

Load attached to carrier OR Load supported by other mechanism

DISTANCE FROM CENTER OF CARRIER TO LOAD CENTER OF GRAVITY

d_x _____
 d_y _____
 d_z _____

inch (U.S. Standard) millimeter (Metric)

STROKE LENGTH

inch (S) (U.S. Standard) millimeters (M) (Metric)

NOTE: If load or force on carrier changes during cycle use the highest numbers for calculations

LOAD

lb. (U.S. Standard) kg. (Metric)

THRUST REQUIRED

lbf. (U.S. Standard) N (Metric)

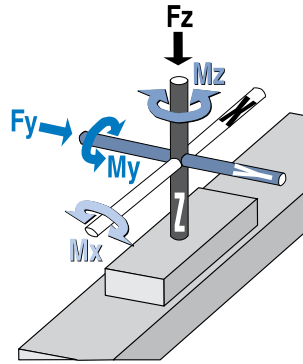

BENDING MOMENTS APPLIED TO CARRIER

in.-lbs. (U.S. Standard) N-m (Metric)

M_x _____
 M_y _____
 M_z _____

PRECISION

Repeatability _____
 inch millimeters

OPERATING ENVIRONMENT

Temperature, Contamination, etc.

MOVE PROFILE

Move Distance _____

inch millimeters

Dwell Time After Move _____

Max. Speed _____

in/sec mm/sec

MOVE TIME

sec

NO. OF CYCLES

per minute per hour

SCREW DRIVE

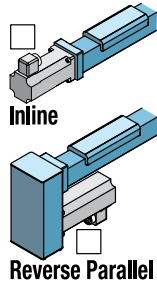

MOTION PROFILE

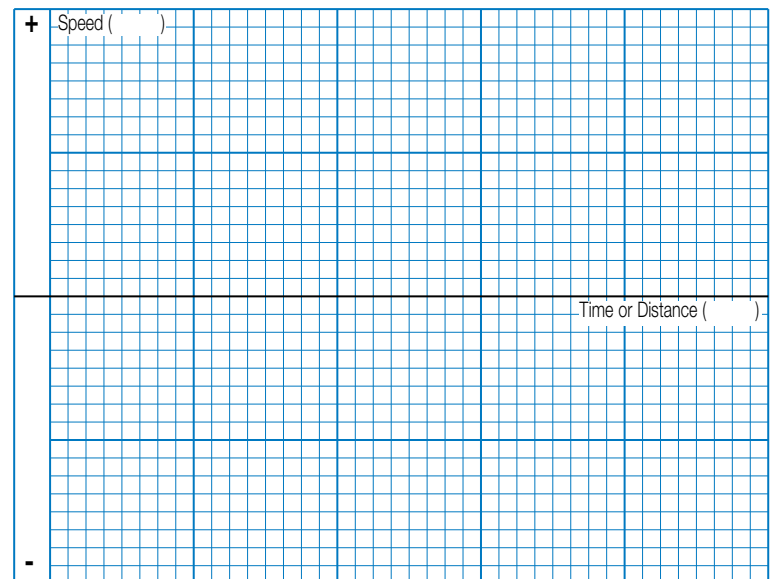

Graph your most demanding cycle, including accel/decel, velocity and dwell times. You may also want to indicate load variations and I/O changes during the cycle. Label axes with proper scale and units.



USE THE TOLOMATIC SIZING AND SELECTION SOFTWARE AVAILABLE ONLINE AT www.tolomatic.com OR... CALL TOLOMATIC AT 1-800-328-2174.

We will provide any assistance needed to determine the proper actuator for the job.

FAX 1-763-478-8080

EMAIL help@tolomatic.com

CONTACT INFORMATION

Name, Phone, Email _____
 Co. Name, Etc. _____

SELECTION GUIDELINES

The process of selecting a load bearing actuator for a given application can be complex. It is highly recommended that you contact Tolomatic or a Tolomatic Distributor for assistance in selecting the best actuator for your application. The following overview of the selection guidelines are for educational purposes only. The Tolomatic Sizelt Software is also available on Tolomatic.com

1 CHOOSE ACTUATOR SIZE

Choose an actuator that has the thrust, speed and moment load capacity to move the load. Use the Critical Speed graph (page TRS_9) for the screw and the Moment and Load Capacity table (pg. TRS_6) for the actuator.

2 COMPARE LOAD TO MAXIMUM LOAD CAPACITIES

Calculate the application load (combination of load mass and forces applied to the carrier) and application bending moments (sum of all moments Mx, My, and Mz applied to the carrier). Be sure to evaluate the magnitude of dynamic inertia moments. When a rigidly attached load mass is accelerated or decelerated, its inertia induces bending moments on the carrier. Careful attention to how the load is decelerated at

the end of the stroke is required for extended actuator performance and application safety. If either load or any of your moments exceed figures indicated in the Moment and Load Capacity table (pg. TRS_6) for the actuator consider:

- 1) Higher capacity bearing style
- 2) A larger actuator size
- 4) External guide system

3 CALCULATE LOAD FACTOR LF

For loads with a center of gravity offset from the carrier account for both applied (static) and dynamic loads. The load factor (LF) must not exceed the value of 1.0

$$L_f = \frac{M_x}{M_{x_{max}}} + \frac{M_y}{M_{y_{max}}} + \frac{M_z}{M_{z_{max}}} + \frac{F_y}{F_{y_{max}}} + \frac{F_z}{F_{z_{max}}} \leq 1.0$$

If LF exceeds the value of 1.0, consider the four choices listed in step #2.

4 ESTABLISH YOUR MOTION PROFILE AND CALCULATE ACCELERATION RATE

Using the application stroke length and maximum carrier velocity (or time to complete the linear motion), establish the motion profile. Select either triangular (accel-decel) or trapezoidal (accel-constant speed-decel) profile. Now calculate the maximum acceleration and deceleration rates of the move. A TRS twin rail screw-driven actuator speed should not exceed the value in the critical speed capacity graph (page TRS_9) for the screw/nut combination chosen. Also, do not exceed safe rates of dynamic inertia moments determined in step #3.

5 SELECT THE LEAD SCREW

Based on the application requirements for accuracy,

backlash, quiet operation, life, etc. select the appropriate screw type (ball screw or roller screw) and the pitch (lead). For additional information on screw selection, consult "Selecting the Optimal Screw Technology" (#9900-4644) available at www.tolomatic.com.

6 SELECT MOTOR AND DRIVE

To help select a motor and drive, leverage the Tolomatic Sizelt software, available on Tolomatic.com to calculate the application thrust and torque requirements.

7 CONSIDER OPTIONS

- TC_ Toe clamps
- C2C Carrier-to-carrier mounting
- Switches - Reed, Solid State PNP or NPN, all available normally open or normally closed

SPEED FACTOR

FOR APPLICATIONS WITH HIGH SPEED OR SIGNIFICANT SHOCK AND VIBRATION: Loads and bending moments must be multiplied by speed factor from the graph below to obtain full rated life of profiled rail bearing system.

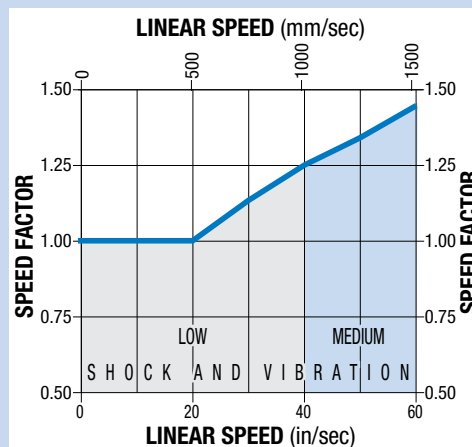

sizeit.tolomatic.com
for fast, accurate
actuator selection

Use Tolomatic Sizing Software to determine available options and accessories based on your application requirements.

TRS Twin Rail Stage Actuator

ORDERING

BASE MODEL SPECIFICATIONS

TRS 100 BNM05 SM200.50 RPL1

MODEL
TRS Twin Rail Stage

SIZE
100 or **165**

NUT/SCREW CONFIGURATION
 BNM05 Ball Nut, 5 mm lead
 BNM10 Ball Nut, 10 mm lead
 RN05 Roller Nut, 5 mm lead
 RN10 Roller Nut, 10 mm lead

STROKE LENGTH
SM Stroke, then enter desired stroke length in millimeters

	MAX. STROKE	
TRS100	750	29.5
TRS165	1100	43.3
	mm	in

MOTOR MOUNTING / REDUCTIONS

⚠ The length on the leadscrew and coupling device is determined by motor selection. Motor type and frame size must be specified when ordering.
(must choose one)

LMI In-Line mount
RPL1 1:1 Reverse-Parallel mount left
RPR1 1:1 Reverse-Parallel mount right
RPB1 1:1 Reverse-Parallel mount bottom
RPT1 1:1 Reverse-Parallel mount top

FIELD RETROFIT

ITEM	
Dust Band Repair Kit	RK then Model & Stroke in millimeters DB
	<i>Example: RK TRS 100 SM200.50 DB</i>

OPTIONS SPECIFICATIONS

TC6 C2C RY1 RK2 YM_x_x_x_x_x_x

BASE MOUNTING
Blank Standard bottom threaded holes, no Toe clamp mounting slots
TCx Toe clamps + mounting slots*
 *x = number of toe clamps

CARRIER MOUNTING
Blank Standard Carrier
C2C Carrier-to-carrier mounting**
 **Only available with 100 mm frame size
⚠ Due to the complexity of the moment loads in a carrier to carrier system, Tolomatic recommends working with a Tolomatic representative to size the system

MOTOR
YM_ Your Motor Here (≤ 70 mm flange)

⚠ Not all codes listed are compatible with all options.

SWITCHES

RY_ Reed Switch (Normally Open) with 5-meter lead, & enter quantity desired
RK_ Reed Switch (Normally Open) with 5-meter lead/QD, & quantity
NY_ Reed Switch (Normally Closed) with 5-meter lead, & quantity
NK_ Reed Switch (Normally Closed) with 5-meter lead/QD, & quantity
TY_ Solid State Switch PNP (Normally Open) with 5-meter lead, & quantity
TK_ Solid State Switch PNP (Normally Open) with 5-meter lead/QD, & quantity
KY_ Solid State Switch NPN (Normally Open) with 5-meter lead, & quantity
KK_ Solid State Switch NPN (Normally Open) with 5-meter lead/QD, & quantity
PY_ Solid State Switch PNP (Normally Closed) with 5-meter lead, & quantity
PK_ Solid State Switch PNP (Normally Closed) with 5-meter lead/QD, & quantity
HY_ Solid State Switch NPN (Normally Closed) with 5-meter lead, & quantity
HK_ Solid State Switch NPN (Normally Closed) with 5-meter lead/QD, & quantity



tolomatic.com/yhm
YOUR MOTOR HERE
 Motor Mounts
 Made-to-Order



sizeit.tolomatic.com
 for fast, accurate
 actuator selection



tolomatic.com/ask
 Technical support
 before and after
 purchase

Available FREE at www.tolomatic.com

The Tolomatic Difference Expect More From the Industry Leader:



INNOVATIVE PRODUCTS

Unique linear actuator solutions with Endurance TechnologySM to solve your challenging application requirements.



FAST DELIVERY

The fastest delivery of catalog products... Built-to-order with configurable stroke lengths and flexible mounting options.



ACTUATOR SIZING

Online sizing that is easy to use, accurate and always up-to-date. Find a Tolomatic electric actuator to meet your requirements.



YOUR MOTOR HERE

Match your motor with compatible mounting plates that ship with any Tolomatic electric actuator.



3D CAD LIBRARY

Easy to access CAD files available in the most popular formats to place directly into your assembly.



TECHNICAL SUPPORT

Extensive motion control knowledge: Expect prompt, courteous replies to any application and product questions from Tolomatic's industry experts.

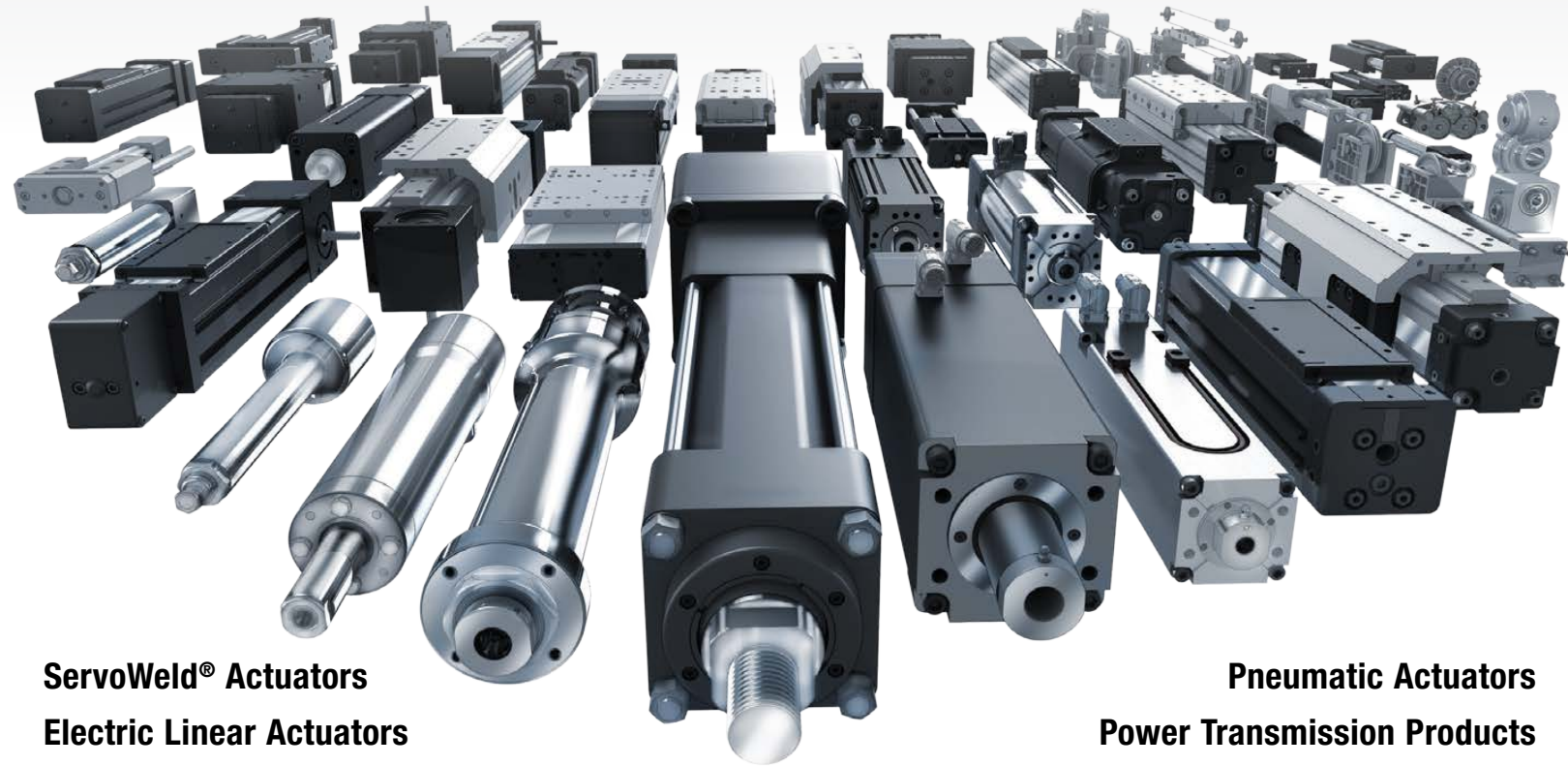

ServoWeld[®] Actuators
Electric Linear Actuators

Pneumatic Actuators
Power Transmission Products

TolomaticTM
EXCELLENCE *IN* MOTION

COMPANY WITH
QUALITY SYSTEM
CERTIFIED BY DNV GL
= ISO 9001 =
Certified site: Hamel, MN

USA - Headquarters

Tolomatic Inc.
3800 County Road 116
Hamel, MN 55340, USA
Phone: (763) 478-8000
Toll-Free: **1-800-328-2174**
sales@tolomatic.com
www.tolomatic.com

MEXICO

Centro de Servicio
Parque Tecnológico Innovación
Int. 23, Lateral Estatal 431,
Santiago de Querétaro,
El Marqués, México, C.P. 76246
Phone: +1 (763) 478-8000
help@tolomatic.com

EUROPE

Tolomatic Europe GmbH
Elisabethenstr. 20
65428 Rüsselsheim
Germany
Phone: +49 6142 17604-0
help@tolomatic.eu

CHINA

Tolomatic Automation Products (Suzhou) Co. Ltd.
No. 60 Chuangye Street, Building 2
Huqiu District, SND Suzhou
Jiangsu 215011 - P.R. China
Phone: +86 (512) 6750-8506
TolomaticChina@tolomatic.com

All brand and product names are trademarks or registered trademarks of their respective owners. Information in this document is believed accurate at time of printing. However, Tolomatic assumes no responsibility for its use or for any errors

that may appear in this document. Tolomatic reserves the right to change the design or operation of the equipment described herein and any associated motion products without notice. Information in this document is subject to change without notice.

Visit www.tolomatic.com for the most up-to-date technical information