

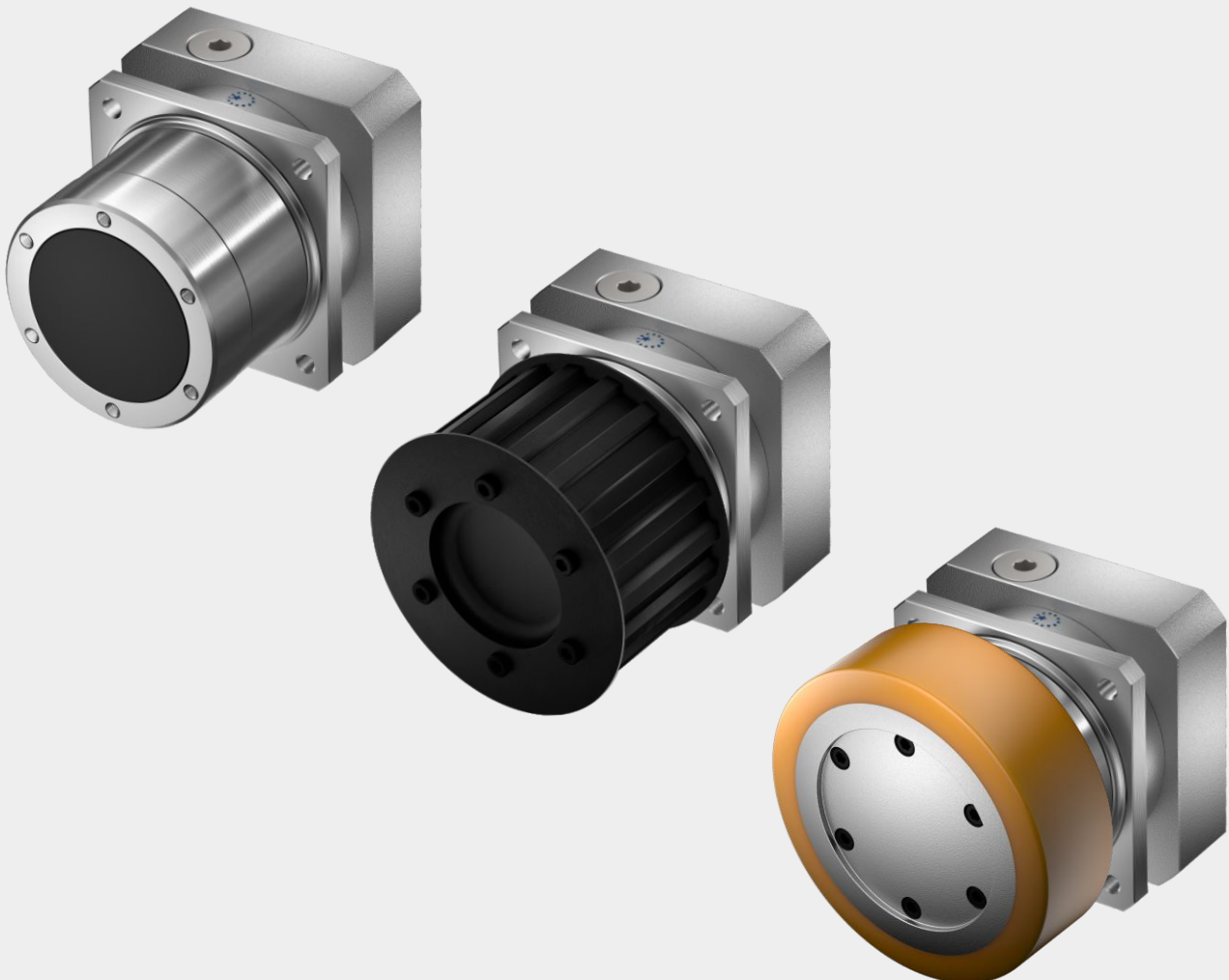

APEX DYNAMICS, INC.

**NEW GENERATION
PLANETARY GEARBOX**

GL / GLS - SERIES



Gearbox Series - GL

► Features:

- High radial load
- Rotating housing
- High efficiency
- Low noise
- Reduced backlash
- Optimized Inertia moment
- Limited temperature rise
- Long service life
- Optimized output torque

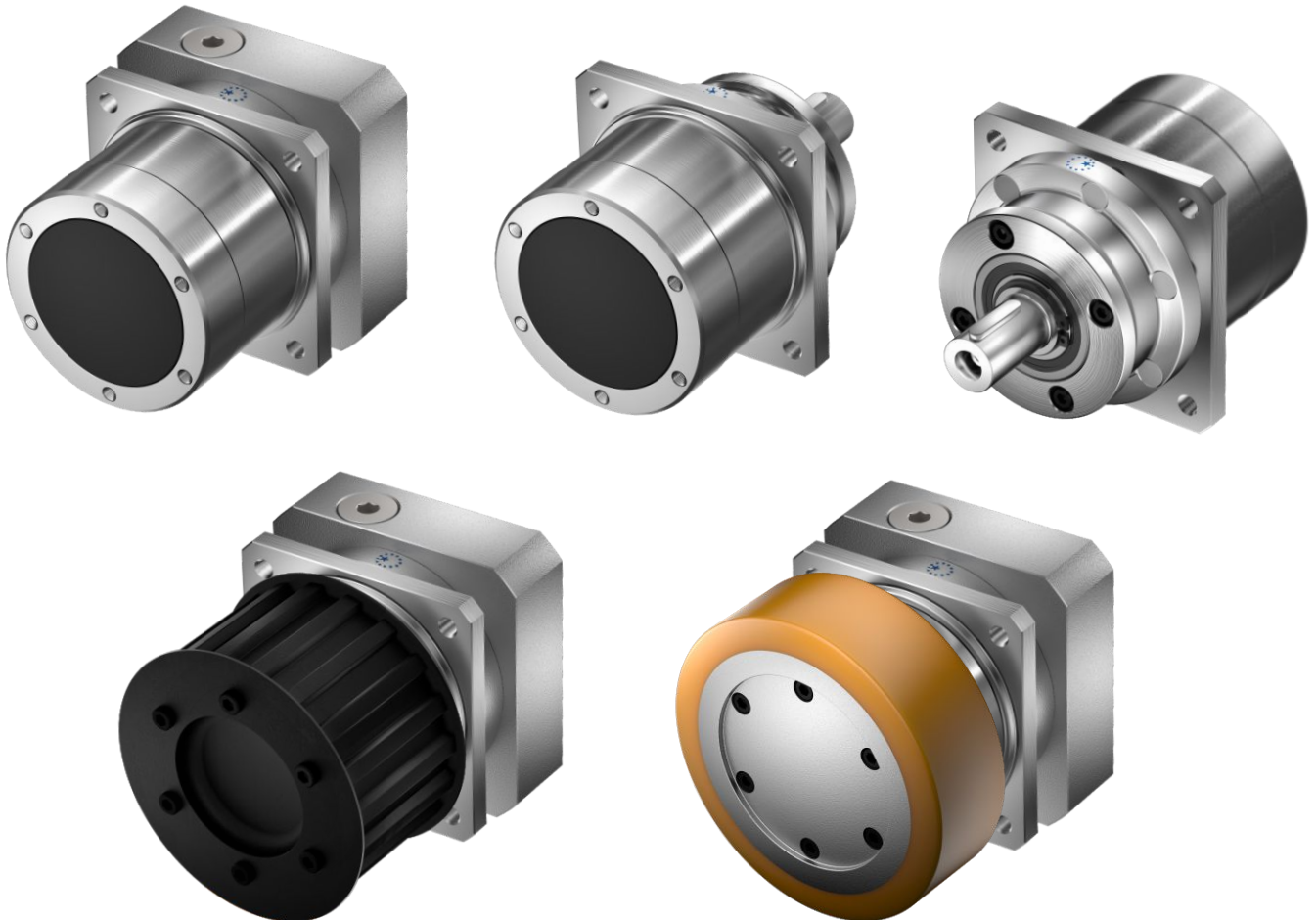

Ordering Code - GL / GLS Gearbox

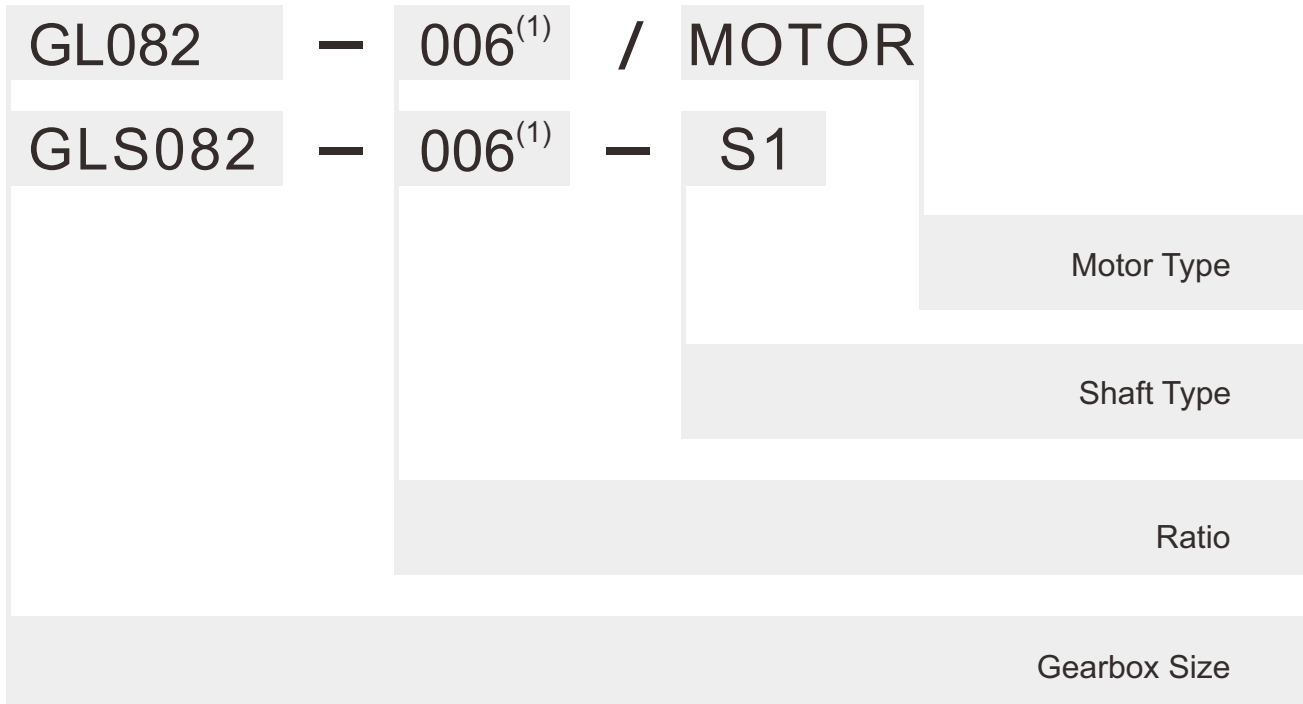

GLS is the GL version with option input “SHAFT” instead of input “HUB”

Gearbox Size
 GL 082 / 100 / 132
 GLS 082 / 100 / 132

Ratio⁽²⁾
 GL 2 / 3 / 4 / 6 / 9
 10 / 15 / 20 / 24 / 30 / 36 / 40 / 45 / 60 / 90
 GLS 3 / 4 / 6 / 9
 10 / 15 / 20 / 24 / 30 / 36 / 40 / 45 / 60 / 90

Shaft Type : S1 = Smooth Input Shaft
 S2 = Input Shaft with Key

Motor Type
Manufacturer and Model

(1) Ratio ($i = N_{in} / N_{out}$).

(2) Please refer to the specifications for the ratios provided in each series.



Performance - GL Gearbox

| Model No. | | Stage | Ratio ⁽¹⁾ | GL082 | GL100 | GL132 |
|---|-----------|-------|----------------------|------------------------------|-----------|-----------|
| Nominal Output Torque T_{2N} | Nm | 1 | 2 | 60 | 102 | 280 |
| | | | 3 | 90 | 155 | 355 |
| | | | 4 | 83 | 168 | 308 |
| | | | 6 | 54 | 115 | 252 |
| | | | 9 | 21 | 50 | 145 |
| | | 2 | 10 | 60 | 102 | 280 |
| | | | 15 | 90 | 155 | 355 |
| | | | 20 | 83 | 168 | 308 |
| | | | 24 | 54 | 115 | 252 |
| | | | 30 | 54 | 115 | 252 |
| | | | 36 | 21 | 50 | 145 |
| | | | 40 | 53 | 96 | 229 |
| | | | 45 | 21 | 50 | 145 |
| | | | 60 | 54 | 115 | 252 |
| | | | 90 | 21 | 50 | 145 |
| Emergency Stop Torque T_{2NOT} | Nm | 1,2 | 2~90 | 3 times T_{2N} | | |
| Max. Acceleration Torque T_{2B} | Nm | 1,2 | 2~90 | 1.5 times T_{2N} | | |
| No Load Running Torque ⁽²⁾ | Nm | 1 | 2~9 | 0.45 | 0.7 | 1.4 |
| | | 2 | 10~90 | 0.2 | 0.3 | 0.6 |
| Backlash ⁽³⁾ | arcmin | 1 | 2~9 | ≤ 3 | ≤ 3 | ≤ 3 |
| | | 2 | 10~90 | ≤ 5 | ≤ 5 | ≤ 5 |
| Torsional Rigidity | Nm/arcmin | 1,2 | 2~90 | 8 | 22 | 60 |
| Nominal Input Speed n_{1N} | rpm | 1 | 2~9 | 5,000 | 3,600 | 3,600 |
| | | 2 | 10~90 | 5,000 | 4,600 | 4,600 |
| Max. Input Speed n_{1B} | rpm | 1 | 2~9 | 7,000 | 6,000 | 6,000 |
| | | 2 | 10~90 | 7,000 | 7,000 | 7,000 |
| Max. Radial Load F_{2r} ⁽⁴⁾ | N | 1,2 | 2~90 | 2,860 | 3,400 | 7,200 |
| Max. Axial Load F_{2a} ⁽⁴⁾ | N | 1,2 | 2~90 | 1,430 | 1,700 | 3,600 |
| Max. Tilting Moment M_{2k} ⁽⁴⁾ | Nm | 1,2 | 2~90 | 117 | 155 | 452 |
| Operating Temp | °C | 1,2 | 2~90 | -10° C ~ 90° C | | |
| Degree of Gearbox Protection | | 1,2 | 2~90 | IP65 | | |
| Lubrication | | 1,2 | 2~90 | Synthetic lubrication grease | | |
| Mounting Position | | 1,2 | 2~90 | All directions | | |
| Running Noise ⁽²⁾ | dB(A) | 1 | 2~9 | ≤ 58 | ≤ 59 | ≤ 64 |
| | | 2 | 10~90 | ≤ 58 | ≤ 59 | ≤ 60 |
| Efficiency η | % | 1 | 2~9 | $\geq 97\%$ | | |
| | | 2 | 10~90 | $\geq 94\%$ | | |

(1) Ratio ($i = N_{in} / N_{out}$).

(2) The dB values are measured by gearbox with ratio 9 (1-stage) or ratio 90(2-stage),
No loading at 3,000 RPM or at the respective Nominal Input Speed by bigger model size.
By lower ratio and/or higher RPM, the noise level could be 3 to 5 dB(A) higher

(3) Backlash is measured at 2% of Nominal Output Torque T_{2N} .

(4) Applied to the output flange center at 100 rpm. The calculation formula please refer to Fig 1.

(5) Continuous operation is not recommended.

Inertia - GL Gearbox

| Model No. | GL082 | | GL100 | | GL132 | |
|---------------------|----------|----------|----------|----------|----------|----------|
| $\varnothing^{(A)}$ | 1-stage. | 2-stage. | 1-stage. | 2-stage. | 1-stage. | 2-stage. |
| 8 | - | 0.1 | - | - | - | - |
| 11 | 0.21 | 0.16 | - | 0.17 | - | - |
| 14 | 0.24 | 0.2 | 0.54 | 0.21 | - | 0.42 |
| 19 | 0.64 | - | 0.79 | 0.6 | 2.51 | 0.66 |
| 24 | - | - | 4.06 | - | 4.78 | 3.94 |
| 28 | - | - | - | - | 6.15 | - |
| 32 | - | - | - | - | 8.03 | - |
| 35 | - | - | - | - | 14.72 | - |
| 38 | - | - | - | - | 17.38 | - |
| 42 | - | - | - | - | - | - |
| 48 | - | - | - | - | - | - |

(A) \varnothing = Input shaft diameter.

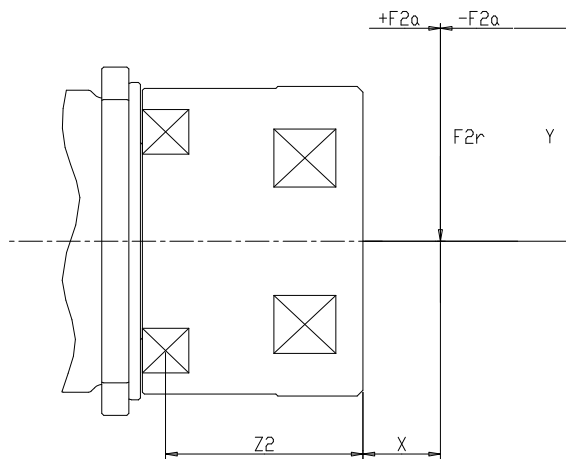

Fig.1

$$\text{Max. Tilting Moment } M_{2k} = \frac{F_{2a} * Y + F_{2r} * (X + Z2)}{1000}$$

M_{2k} : [Nm]
 F_{2a}, F_{2r} : [N]
 $X, Y, Z2$: [mm]

| GL | 082 | 100 | 132 |
|---------|-----|-----|------|
| Z2 [mm] | 51 | 57 | 78.5 |

Note : Applied to the output flange center at 100 rpm.

Dimension - GL Gearbox

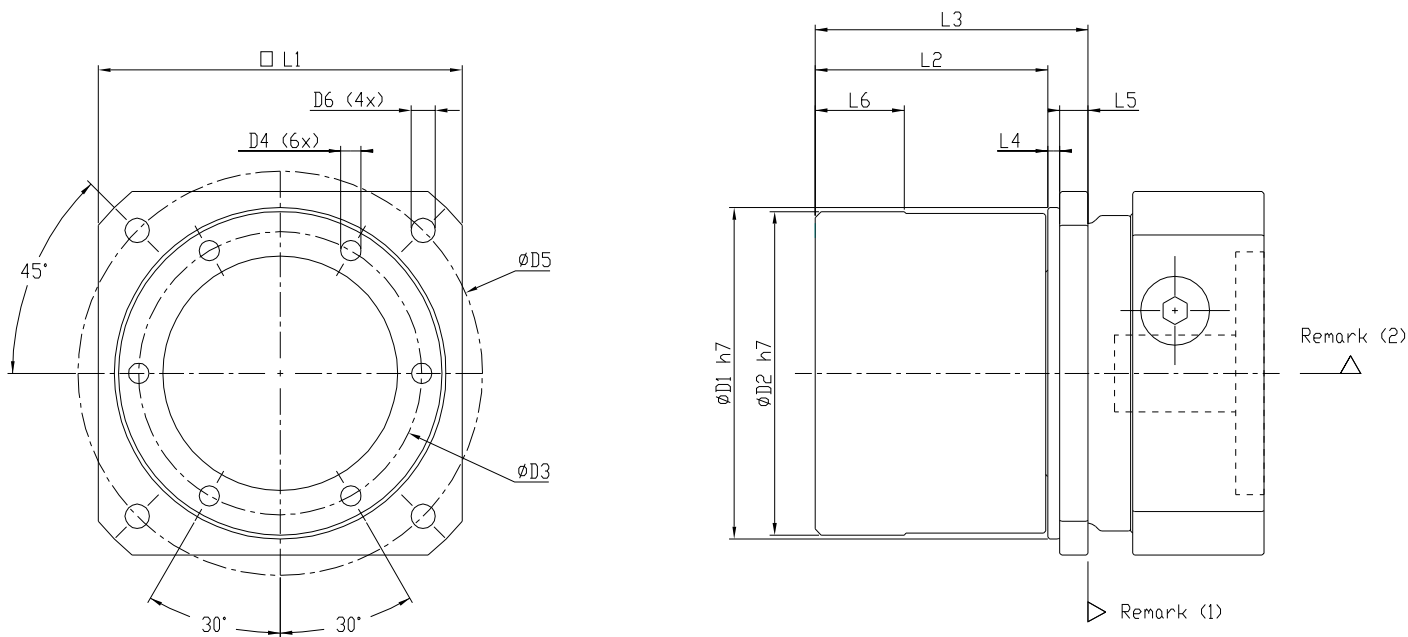

| Dimension | GL082 | GL100 | GL132 |
|-------------------|-----------|----------|---------------|
| D1 h7 | 82 | 100 | 132 |
| D2 h7 | 80 | 96 | 128 |
| D3 | 70 | 84 | 114 |
| D4 x Pitch x Deep | M5x0.8Px8 | M6x1Px10 | M8x1.25Px12.5 |
| D5 | 100 | 122 | 166 |
| D6 | M6x1P | M8x1.25P | M10x1.5P |
| L1 | 90 | 108 | 140 |
| L2 | 57.5 | 62.5 | 85.5 |
| L3 | 67.5 | 75.5 | 101.5 |
| L4 | 3 | 3.5 | 4 |
| L5 | 7 | 9.5 | 12 |
| L6 | 22 | 24 | 34 |

(1) Dimensions are related to motor interface. Please contact APEX for details.

(2) As alternative to input "HUB", input "SHAFT" is also available, please find in page 06.

Dimension - GLS (Input Shaft as Option)

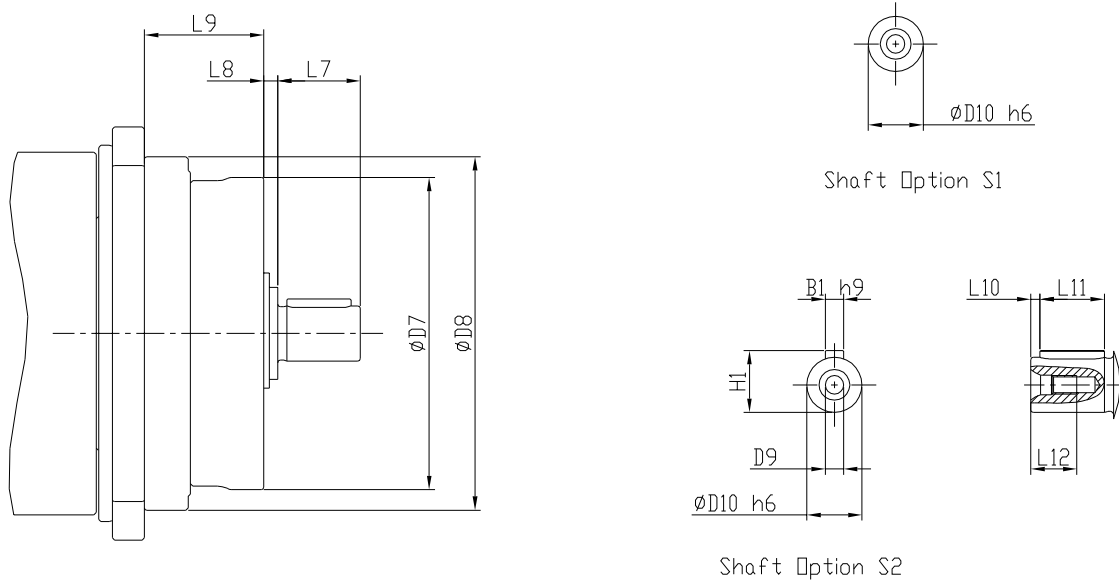

| Dimension | Stage | GLS082 | GLS100 | GLS132 |
|-----------|-------|---------|----------|----------|
| D7 | 1 | 68 | 84 | 93 |
| | 2 | 60 | 68 | 84 |
| D8 | 1,2 | 77 | 100 | 136 |
| D9 | 1 | M4x0.7P | M8x1.25P | M10x1.5P |
| | 2 | M3x0.5P | M4x0.7P | M8x1.25P |
| D10 h6 | 1 | 12 | 22 | 28 |
| | 2 | 10 | 12 | 22 |
| L7 | 1 | 18 | 36 | 42 |
| | 2 | 15 | 18 | 36 |
| L8 | 1 | 3 | 3 | 4 |
| | 2 | 3 | 3 | 3 |
| L9 | 1 | 26 | 38 | 45.5 |
| | 2 | 44.5 | 54 | 67.5 |
| L10 | 1 | 2 | 3 | 5 |
| | 2 | 2 | 2 | 3 |
| L11 | 1 | 14 | 28 | 32 |
| | 2 | 10 | 14 | 28 |
| L12 | 1 | 10 | 19 | 22 |
| | 2 | 9 | 10 | 19 |
| B1 h9 | 1 | 4 | 6 | 8 |
| | 2 | 3 | 4 | 6 |
| H1 | 1 | 13.5 | 24.5 | 31 |
| | 2 | 11.2 | 13.5 | 24.5 |

Performance - GLS (Input Shaft as Option)

| Model No. | | Stage | Ratio ⁽¹⁾ | GLS082 | GLS100 | GLS132 |
|---|--------------------|-------|----------------------|--------|--------|--------|
| Max. Radial Load F_{1rB} ⁽²⁾ | N | 1 | 3~9 | 460 | 600 | 800 |
| | | 2 | 10~90 | 275 | 460 | 600 |
| Max. Axial Load F_{1aB} ⁽²⁾ | N | 1 | 3~9 | 230 | 300 | 400 |
| | | 2 | 10~90 | 137 | 230 | 300 |
| Moment of Inertia | kg.cm ² | 1 | 3~9 | 0.19 | 0.62 | 1.78 |
| | | 2 | 10~90 | 0.06 | 0.19 | 0.62 |

(1) Ratio ($i = N_{in} / N_{out}$).

(2) Applied to the input shaft center at 1000 rpm.

Selection of the optimum gearbox

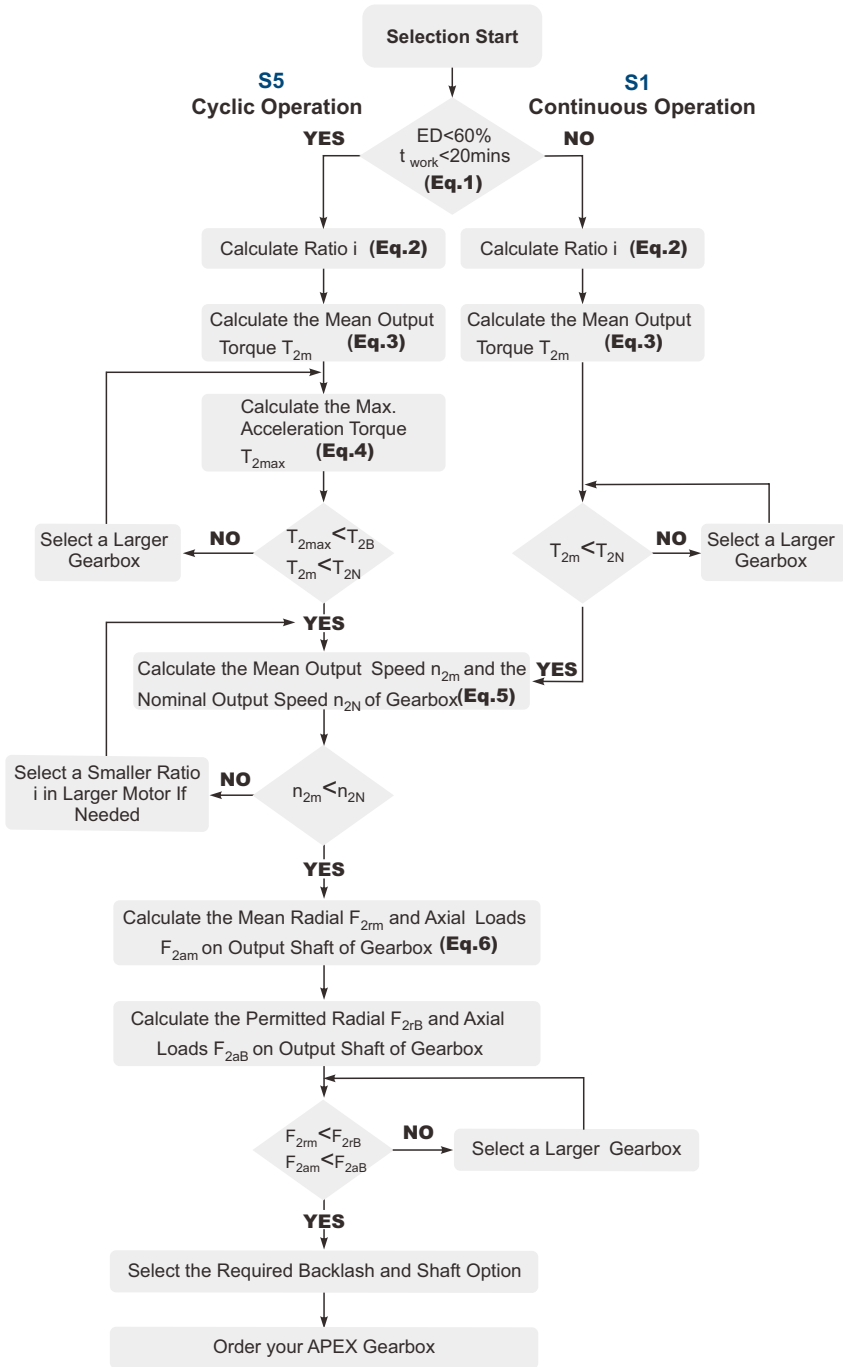

Recommended (for S5 Cycle Operation)

The general design is given for

$$\frac{J_L}{i^2} \leq 4 \times J_m$$

The optimal design is given for

$$\frac{J_L}{i^2} \cong J_m$$

J_L Load Inertia

J_m Motor Inertia

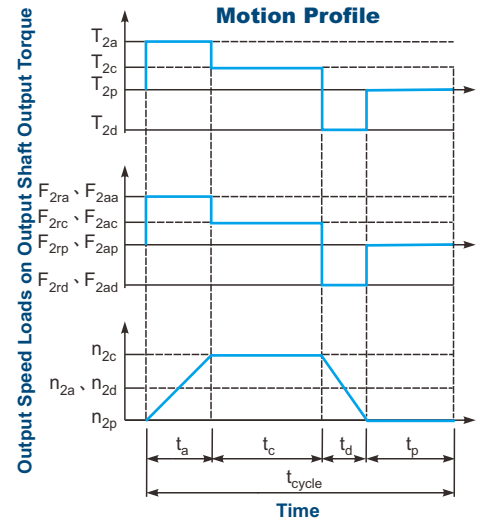

$$1. ED = \frac{t_a + t_c + t_d}{t_{cycle}} \times 100\%, t_{work} = t_a + t_c + t_d$$

Index : a. Acceleration, c. Constant,
d. Deceleration, p. Pause **(Eq.1)**

$$2. i \cong \frac{n_m}{n_{work}}$$

n_m Output Speed of the Motor
 n_{work} Working Speed **(Eq.2)**

$$3. T_{2m} = 3 \sqrt{\frac{n_{2a} \times t_a \times T_{2a}^3 + n_{2c} \times t_c \times T_{2c}^3 + n_{2d} \times t_d \times T_{2d}^3}{n_{2a} \times t_a + n_{2c} \times t_c + n_{2d} \times t_d}}$$

(Eq.3)

$$4. T_{2max} = T_{mB} \times i \times K_s \times \eta$$

where K_s is

| K_s | No. of Cycles / hr |
|-------|--------------------|
| 1.0 | 0 ~ 1,000 |
| 1.1 | 1,000 ~ 1,500 |
| 1.3 | 1,500 ~ 2,000 |
| 1.6 | 2,000 ~ 3,000 |
| 1.8 | 3,000 ~ 5,000 |

T_{mB} Max. Output Torque of the Motor

η Efficiency of the Gearbox **(Eq.4)**

$$5. n_{2a} = n_{2d} = \frac{1}{2} \times n_{2c}$$

$$n_{2m} = \frac{n_{2a} \times t_a + n_{2c} \times t_c + n_{2d} \times t_d}{t_a + t_c + t_d}$$

$$n_{2N} = \frac{n_{1N}}{i}$$

(Eq.5)

$$6. F_{2rm} = 3 \sqrt{\frac{n_{2a} \times t_a \times F_{2ra}^3 + n_{2c} \times t_c \times F_{2rc}^3 + n_{2d} \times t_d \times F_{2rd}^3}{n_{2a} \times t_a + n_{2c} \times t_c + n_{2d} \times t_d}}$$

$$F_{2am} = 3 \sqrt{\frac{n_{2a} \times t_a \times F_{2aa}^3 + n_{2c} \times t_c \times F_{2ac}^3 + n_{2d} \times t_d \times F_{2ad}^3}{n_{2a} \times t_a + n_{2c} \times t_c + n_{2d} \times t_d}}$$

(Eq.6)

Glossary

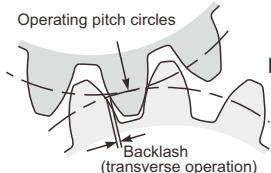
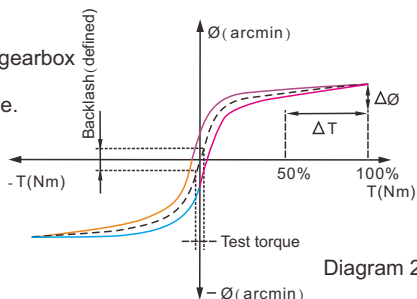
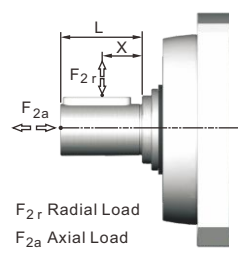
| | | |
|-----------------------------------|--------------------|--|
| Emergency Stop Torque T_{2NOT} | Nm | The Emergency Stop Torque is the maximum permitted torque at the output of gearbox. This may happen only occasionally and may not exceed 1,000 times during the whole service life. |
| Max. Acceleration Torque T_{2B} | Nm | Under the Cyclic Operation (S5), the Max. Acceleration Torque is the maximum torque which can be transmitted only briefly to the output of gearbox up to 1,000 cycles/hr. |
| No Load Running Torque | Nm | The No Load Running Torque is the min. torque to overcome the internal friction of a gearbox without loading*. |
| Nominal Input Speed n_{1N} | rpm | The Nominal Input Speed is the permitted input speed of gearbox by the Continuous Operation (S1) while the housing temperature does not exceed 90°C. This value is measured at environment temperature 25°C. |
| Max. Input Speed n_{1B} | rpm | The Max. Input Speed is the max. permitted input speed of gearbox by the Cyclic operation (S5). This value is measured at environment temperature 25°C and serves as the absolute limit of the gearbox. |
| Backlash | arcmin | <p>The Backlash is the maximum angular measurement between two teeth of gears when the transverse operation occurs (refer to Diagram 1). The arcmin is the measurement unit for the backlash. One arcmin equals 1/60 degree, symbolized as 1'.</p>  |
| Torsional Rigidity | Nm/arcmin | <p>Torsional Rigidity is the quotient ($\Delta T / \Delta \theta$) between the applied torque and resulting torsion angle. This value indicates how much torque is needed on the gearbox to rotate the output shaft for 1 arcmin. The Torsional Rigidity can be determined by Hysteresis Curve.</p> <p>Hysteresis Curve When the input shaft is locked, increase torque at the output slowly up to T_{2B} in both directions and then release the torque gradually. According to the measured torque and torsion angle, a closed curve will be acquired as in the Diagram 2.</p>  |
| Radial Load And Axial Load | N | <p>The permitted radial and axial loads on output shaft of the gearbox depend on the design of the gearbox supporting bearings.</p> <p>For more information, please refer to APEX website.</p>  |
| Efficiency η | % | The transmission efficiency of the gears inside a gearbox (without friction). |
| Operating Temperature | °C | The Operating Temperature indicates the temperature of gearbox housing. |
| Degree of Protection | | IP code stands for International Protection standard. The IP65 as example: the first IP number stands for protection degree against dust; the second IP number stands for protection against liquid. |
| Lubrication | | APEX uses synthetic lubrication grease. Alternate greases are available, please contact APEX. |
| Running Noise | dB(A) | The Running Noise is measured depends on gearbox size, the ratio and the speed*. Higher speed usually induces higher noise level, while higher ratio induces lower noise level. |
| Moment of Inertia J_1 | kg.cm ² | The Moment of Inertia J_1 is a measurement of the effort applied to an object to maintain its momentary condition at rest or rotating. |
| Breakaway Torque | Nm | The Breakaway Torque is the minimum torque to start the rotation from the input side of gearbox. A smaller size or a higher ratio gearbox requests less Breakaway Torque. |
| Back Driving Torque | Nm | The Back Driving Torque is the minimum torque to start the rotation from the output side of gearbox. A larger size or a higher ratio gearbox requires greater Back Driving Torque. |

* This value is measured at environment temperature 25°C and the input speed 3,000 rpm. If the Nominal Input Speed n_{1N} of gearbox is lower than 3,000 rpm, this value is measured by that specific Nominal Input Speed.



**APEX TAIWAN NORTH
ANDTEK AUTOMATION CO.,LTD**
TEL +886-02-82262655
13F-5, No.2, Jian 8th Rd., Jhonghe Dist., New
Taipei City 235, TAIWAN
sales@andtek.com.tw
www.apexdyna.com



**APEX TAIWAN CENTRAL
ANDTEK AUTOMATION CO.,LTD**
TEL +886-04-23594286
9F-6, No.925, Sec.4, Taiwan Blvd., Xitun Dist.
Taichung City 407 TAIWAN
sales@andtek.com.tw
www.apexdyna.com



**APEX TAIWAN SOUTH
MEN JENN ELECTRIC CO., LTD.**
TEL +886-06-2337332 ~ 6
No.774, Zhonghua Rd., Yongkang Dist., Tainan
City 710, TAIWAN
menjenn@ms24.hinet.net
www.apexdyna.com



APEX DYNAMICS INC. SHANGHAI
TEL +86-21-69220577
No.128 ZHUYING Road QINGPU Industry Area,
Shanghai, CHINA
sales@apexdyna.cn
www.apexdyna.cn



APEX DYNAMICS SHENZHEN, LTD.
TEL +86-755-84516325
No. 1102A of D area , CFG mansion ,Bao Yuan
Road , Bao'an District , Shenzhen ,CHINA.
sales@szapexdyna.com
www.szapexdyna.com



APEX DYNAMICS BEIJING, LTD.
TEL +86-10-69570691
NO.1,YaoPingRoad,SongZhuang Town, Tongzhou
istrict, Beijing, CHINA.
bjapexdyna@163.com
www.bjapex.cn



CHONGQING APEX DYNAMICS CO., LTD.
TEL +86-23-67686860
406, Building 5, No.68, Jinyu Avenue, Beibu New
Area, Chongqing, CHINA
sales@cqapexdyna.com
www.apexdyna.com



APEX (XIAMEN) DYNAMICS TECHNOLOGY CO., LTD.
TEL +86-0592-720-5279
Unit B-3,1F.,No.129,Jingquan Road, Jimei District,
Xiamen, Fujian, CHINA
sales@xmapexdyna.com
www.xmapexdyna.com



APEX DYNAMICS USA, INC.
TEL +1-631-2449040
885 Marconi Avenue Ronkonkoma, NY 11779
U.S.A.
sales@apexdynamicsusa.com
www.apexdynamicsusa.com



APEX DYNAMICS KOREA
TEL +82-31-8179992
1246-32, Seongsuk-dong, Ilsandong-gu, Goyang-city,
Gyeonggi-Do, KOREA (R.O.K) 410-570
sales@apexdynakorea.co.kr
www.apexdynakorea.co.kr



APEX DYNAMICS JAPAN
TEL +86-092-4511202
1-3-46, Hanmichibasi, Hakata-ku, Fukuoka,
812-0897, JAPAN
sales@apexdyna.jp
www.apexdyna.jp



APEX DYNAMICS SINGAPORE PTE LTD
TEL +65-62-626228
3 South Buona Vista Road, #05-15 & #06-15.
SINGAPORE 118136
sales@apexdyna.com.sg
www.apexdyna.com.sg



APEX DYNAMICS (THAILAND) CO., LTD.
TEL +66-2-3266233
73 Soi Ladkrabang 30, Kadkrabang Rd.,Bangkok
10520, THAILAND
sales@apexdyna.co.th
www.apexdyna.co.th



APEX DYNAMICS BV
TEL +31-492-509995
Churchillaan 101 5705 BK Helmond, NETHERLANDS
sales@apexdyna.nl
www.apexdyna.nl



**APEX DYNAMICS
POLSKA SP. Z O.O.**
TEL +48-12-6304728
Krakowska 50, 32-083 Balice, POLAND
sales@apexdyna.pl
www.apexdyna.pl



APEX DYNAMICS SPAIN, S.L.
TEL +34-93-6562990
Poligono Industrial Molí dels Frares, Calle C nº
12,08620 - Sant Vicenç dels Horts, Barcelona, SPAIN
apexdyna@apexdyna.es
www.apexdyna.es



LIMAN TRADING LIMITED FZC LLC
P.O. Box 97 , Postal Code 322, Corporate Parks,
Sohar Free Zoon, Oman



APEKS REDUKTOR VE DISLI SAN. TIC. LTD. STI.
TEL +90-232-4589960
10042 Sok.No:10 AOSB Çiğli-İzmir, TURKEY
sales@apexdyna.com.tr
www.apexdyna.com.tr



APEX DYNAMICS AUSTRALIA PTY LTD.
TEL +613-95-852739
36 Taunton Drive, Cheltenham, Victoria 3192
AUSTRALIA.
sales@apexdyna.com.au
www.apexdyna.com.au



APEX DYNAMICS (I) JV
TEL +91-9607927142
Shop No. 02, S. No. 100/5, Pune-Satara Highway,
Ambegaon Khurd, Pune-411046 Maharashtra, India
sales@apexdyna.co.in
www.apexdyna.co.in



APEX DYNAMICS FRANCE SAS
TEL +33-160-135097
11 - Burospace F - 91570 -
Bièvres, FRANCE
info@apexdyna.fr
www.apexdyna.fr



APEX DYNAMICS SWEDEN AB
TEL +46-75-242444
Fredrikbergsgatan 2 SE-573 92 Tranås, SWEDEN
sales@apexdyna.se
www.apexdyna.se



PT.APEX DYNAMICS INDONESIA
TEL +62 21 2928 3681
Rukan Aralia Blok HY43 no.11, Harapan Indah II,
Bekasi - Jawa Barat, INDONESIA 17214
sales@apexdyna.co.id
www.apexdyna.co.id



APEX DYNAMICS GERMANY GMBH
TEL +49-7181-9329955
Spanninger Str. 9, 73650 Winterbach, GERMANY
Langer@apexdynamics.de
www.apexdynamics.de



APEX DYNAMICS CZECH S.R.O.
TEL +420-577-663877
tř. Tomáše Bati 1851 765 02 Otrokovice ČESKÁ
REPUBLIKA
info@apexdynaczech.cz
www.apexdynaczech.cz



APEX DYNAMICS РОССИЯ
TEL +7-495-2255452
+7-495-6462422
r.Москва, ул. Южнопортовая, дом 7, строение
"С", 3-й этаж
info@apexdynarussia.ru
www.apexdynarussia.ru



APEX DYNAMICS UK
TEL +44-0121-737-1170
Heath House, Cheadle Rd, Uttoxeter,
ST14 7BY, UK
mikeg@apexdynauk.com
www.apexdynauk.com



APEX DYNAMICS SWITZERLAND AG
TEL +41-55-4517020 Talstrasse 24, CH-8852
Altendorf, SWITZERLAND
info@apexdyna.ch
www.apexdyna.ch



APEX DYNAMICS MOTION SDN BHD
TEL +60-7267-4228
No.1, Jalan Perniagaan Setia 3, Taman
Perniagaan Setia, 81100 Johor Bahru, Johor,
MALAYSIA (Setia Business Park 2 @ Iskandar
Malaysia)
sales@apexdyna.com.sg
www.apexdyna.com.sg



APEX DYNAMICS BRAZIL
TEL +55-47-30298700
Rua Senador Petrônio Portela, 47 - Bloco 5, Zona
Industrial Norte - CEP 89218-575 - Joinville (SC)
lucan@neoyama.com.br
adriano.duarte@neoyama.com.br
www.neoyama.com.br



APEX DYNAMICS ITALY
TEL +39 02.36634521
VIA E. DE AMICIS, 2 – 20091 BRESSO (MI)
info@apexdynamics.it
www.apexdynamics.it



Apex Dynamics Austria GmbH
TEL +43 07207884160
Dr. Hans-Lechner-Strasse 6,
5071 Wals-Siezenheim
info@apexdynamics.at
www.apexdynamics.at



UAB "APEX DINAMIKA"
TEL +370 52078165
Medaus g. 28A,
Medininku k., Vilniaus r. Sav.
LT-13192
info@apexdyna.lt



APEX DYNAMICS DENMARK
TEL +45 73121260
Grundtvigs Allé 165, 6400
Sønderborg, Denmark
sales@apexdyna.dk
www.apexdyna.dk



APEX DYNAMICS ISRAEL
TEL +972-3-6470471
17 Hamefalsim St., Kiryat Arye,
Petach-Tikva 4951447
Sales@apexdynamics.co.il
www.apexdynamics.co.il



APEX DYNAMICS SLOVAKIA S.R.O.
TEL +421919400476
Trenčianska cesta 887/52, 957 01
Bánovce nad Bebravou, Slovak
republic
office@apexdyna.sk
www.apexdyna.sk



APEX DYNAMICS, INC.

No. 10, Keyuan 3rd Rd., Situn District, Taichung City 40763, Taiwan (R.O.C.)
Tel:886-4-24650219 | Fax:886-4-24650118
sales@apexdyna.com | http://www.apexdyna.com

APEX-2020-10-GL / GLS Series - 1.0

Printed in Taiwan

