

MODEL 758 – INCREMENTAL SHAFT ENCODER



Ø58 mm

FEATURES

- Standard Size 58 Mounting (58 mm Diameter)
- Up to 30,000 CPR
- 80 lb Max. Axial and Radial Shaft Loading
- High Temperature Option (100° C)
- IP67 Sealing Available

The Model 758 Size 58 Accu-Coder™ is a heavy duty, extremely rugged, reliable, yet compact European standard size 58 millimeter diameter encoder, designed for harsh factory and plant floor environments. Shaft loading is no problem for the double-shielded ball bearings; their 80 lb load rating ensures a long operating life. With the optional heavy-duty shaft seal, the Model 758 is rated IP67. Two European standard mounting options are available: Clamping Flange (20 Type) or Synchro Flange (26 Type). The Model 758 is the perfect replacement encoder for units requiring the European mount.

COMMON APPLICATIONS

Motion Control Feedback, Machine & Elevator Controls, Food Processing, Robotics, Material Handling, Conveyors, Textile Machines

MODEL 758 ORDERING GUIDE

Blue type indicates price adder options. Not all configuration combinations may be available. Contact Customer Service for details.

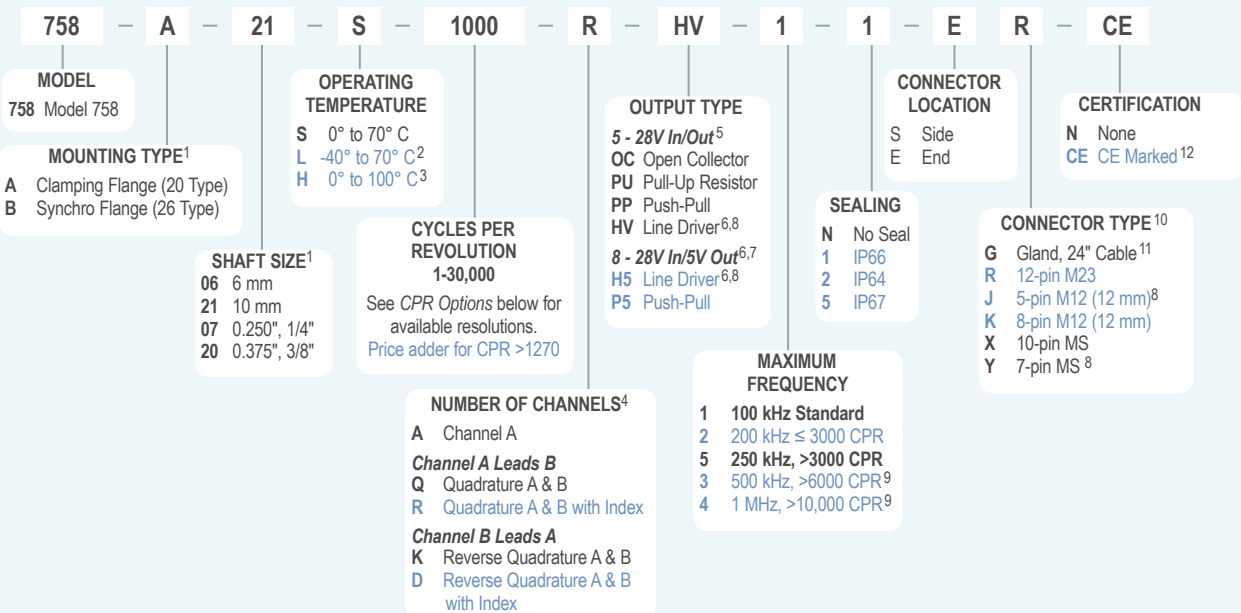

MODEL 758 CPR OPTIONS

0001*	0002*	0004*	0005*	0006*	0007*	0008*	0010*	0011*
0012*	0014*	0020	0021*	0024*	0025*	0028*	0030*	0032*
0033*	0034*	0035*	0038*	0040*	0042*	0045*	0050*	0060
0064*	0100	0120	0125	0128*	0144*	0150*	0160*	0192*
0200	0240*	0250	0254*	0256*	0300	0333*	0336*	0360
0400	0500	0512	0600	0625*	0635	0665*	0720	0768*
0800	0889	1000	1024	1200	1201* ^a	1203* ^a	1204* ^a	1250 ^a
1270 ^a	1440	1500	1800	2000	2048	2400 ^a	2500	2540 ^a
2880 ^a	3000 ^a	3600 ^a	4000 ^a	4096 ^a	5000 ^a	6000 ^a	7200 ^a	7500 ^a
9000 ^a	10,000 ^a	10,240 ^a	12,000 ^a	12,500 ^a	14,400 ^a	15,000 ^a	18,000 ^a	20,000 ^a
20,480 ^a	25,000 ^a	30,000 ^a						

*Contact Customer Service for High Temperature Option (H).

^aHigh Temperature Option (H) limited to 85° C maximum for these CPR options.

New CPR values are periodically added to those listed. Contact Customer Service to determine all currently available CPR values. Special disk resolutions are available upon request.

A one-time NRE fee may apply.

NOTES:

- The shaft on 20 Type mountings includes a 15.58 mm flat. The shaft on 26 Type mountings is provided without a flat.
- Low temperature option not available with resolutions of 3000 CPR or higher.
- 0° to 85° C for certain resolutions, see CPR Options.
- Contact Customer Service for index gating options.
- 24 VDC max for high temperature option.
- H5 and P5 outputs are not available with CE option, or any End Mount MS connector.
- Standard temperature, 60 to 3000 CPR only. Not available with 2540 CPR.
- Line Driver Outputs not available with 5-pin M12 connector. Available with 7-pin MS connector only without Index Z.
- Standard cable lengths only. For details, please refer to Technical Bulletin [TB116: Noise and Signal Distortion Considerations](#) at encoder.com.
- For mating connectors, cables, and cordsets see [Accessories](#) at encoder.com. For Connector Pin Configuration Diagrams, see Technical Information or see [Connector Pin Configuration Diagrams](#) at encoder.com.
- For Non-Standard Cable Lengths add a forward slash (/) plus cable length expressed in feet. Example: SG/6 = 6 feet of cable.
- Please refer to Technical Bulletin [TB100: When to Choose the CE Mark](#) at encoder.com.

MODEL 758 SPECIFICATIONS

Electrical

Input Voltage.....4.75 to 28 VDC max for temperatures up to 70° C
4.75 to 24 VDC for temperatures between 70° C to 100° C

Input Current100 mA max with no output load
Input Ripple.....100 mV peak-to-peak at 0 to 100 kHz

Output Format.....Incremental – Two square waves in quadrature with channel A leading B for clockwise shaft rotation, as viewed from the encoder mounting face.
See *Waveform Diagrams*.

Output Types.....Open Collector – 100 mA max per channel
Pull-Up – Open Collector with 2.2K ohm internal resistor, 100 mA max per channel
Push-Pull – 20 mA max per channel
Line Driver – 20 mA max per channel (Meets RS 422 at 5 VDC supply)

Index.....Occurs once per revolution. The index for units >3000 CPR is 90° gated to Outputs A and B. See *Waveform Diagrams*.

Max Frequency Up to 1 MHz

Electrical Protection ..Reverse voltage and output short circuit protected. NOTE: Sustained reverse voltage may result in permanent damage.

Noise Immunity.....Tested to BS EN61000-4-2; IEC801-3; BS EN61000-4-4; DENV 50141; DENV 50204; BS EN55022 (with European compliance option); BS EN61000-6-2; BS EN50081-2

Symmetry.....1 to 6000 CPR: 180° (±18°) electrical at 100 kHz output
6001 to 20,480 CPR: 180° (±36°) electrical

Quad Phasing.....1 to 6000 CPR: 90° (±22.5°) electrical at 100 kHz output
6001 to 20,480 CPR: 90° (±36°)

Min Edge Sep.....1 to 6000 CPR: 67.5° electrical at 100 kHz output
6001 to 20,480 CPR: 54° electrical
>20,480 CPR: 50° electrical

Rise Time.....Less than 1 microsecond

Accuracy.....Instrument and Quadrature Error:
For 200 to 1999 CPR, 0.017° mechanical (1.0 arc minutes) from one cycle to any other cycle. For 2000 to 3000 CPR, 0.01° mechanical (0.6 arc minutes) from one cycle to any other cycle. Interpolation error (units > 3000 CPR only) within 0.005° mechanical. (Total Optical Encoder Error = Instrument + Quadrature + Interpolation)

Mechanical

Max Shaft Speed.....8000 RPM. Higher shaft speeds may be achievable, contact Customer Service.

Shaft Rotation.....Bi-directional

Radial Shaft Load.....80 lb max. Rated load of 20 to 40 lb for bearing life of 1.5×10^9 revolutions

Axial Shaft Load.....80 lb max. Rated load of 20 to 40 lb for bearing life of 1.5×10^9 revolutions

Starting Torque.....1.0 oz-in typical with IP64 seal or no seal
3.0 oz-in typical with IP66 shaft seal
7.0 oz-in typical with IP67 shaft seal

Moment of Inertia..... 5.2×10^{-4} oz-in-sec²

Housing.....Black non-corrosive finish

Bearings.....Precision ABEC ball bearings

Weight.....11 oz typical

Environmental

Storage Temp.....-25° to 85° C

Humidity.....98% RH non-condensing

Vibration.....20 g @ 58 to 500 Hz

Shock.....75 g @ 11 ms duration

Sealing.....IP50 standard; IP64, IP66 or IP67 optional

MODEL 758 CLAMPING FLANGE 20 TYPE (A)

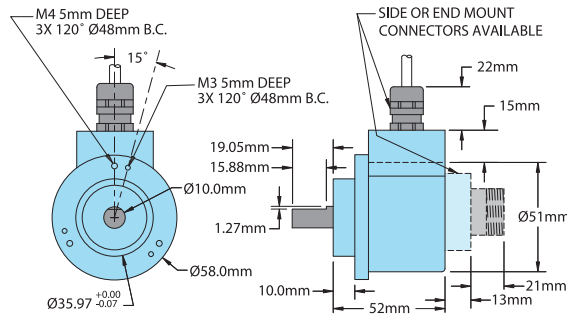

MODEL 758 SYNCHRO FLANGE 26 TYPE (B)

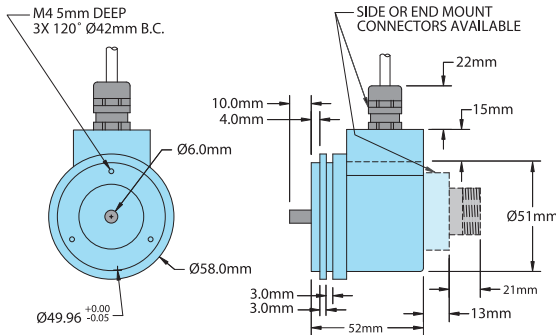

All dimensions are in millimeters with a tolerance of ±0.17 mm unless otherwise specified.

WAVEFORM DIAGRAMS

Open Collector and Pull-Up

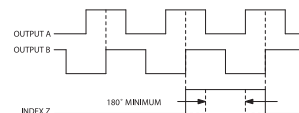

NOTE: ALL DEGREE REFERENCES ARE ELECTRICAL DEGREES. INDEX IS POSITIVE GOING.

Line Driver and Push-Pull

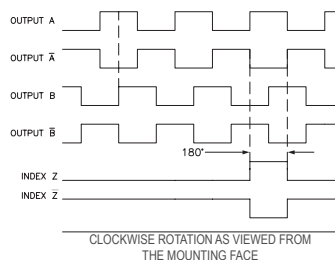

NOTE: ALL DEGREE REFERENCES ARE ELECTRICAL DEGREES. WAVEFORM SHOWN WITH OPTIONAL COMPLEMENTARY SIGNALS A, B, Z FOR HV AND H5 OUTPUTS ONLY.

WIRING TABLE

For EPC-supplied mating cables, refer to wiring table provided with cable. Trim back and insulate unused wires.

Function	Gland Cable† Wire Color	5-pin M12**	8-pin M12**	10-pin MS	7-pin MS HV,H5	7-pin MS PU,PP P5,OC	12-pin M23
Com	Black	3	7	F	F	F	10
+VDC	Red	1	2	D	D	D	12
A	White	4	1	A	A	A	5
A'	Brown	--	3	H	C	--	6
B	Blue	2	4	B	B	B	8
B'	Violet	--	5	I	E	--	1
Z	Orange	5	6	C	--	C	3
Z'	Yellow	--	8	J	--	--	4
Shield	Bare*	--	--	--	--	--	--
+VDC Sense	--	--	--	--	--	--	2
Com Sense	--	--	--	--	--	--	11
Case	Green	--	--	G	G	G	9

*CE Option: Cable shield (bare wire) is connected to internal case.

†Standard cable is 24 AWG conductors with foil and braid shield.

**CE Option: Use cable cordset with shield connected to M12 connector coupling nut.