

Manual No. 100-5319-01
Rev. J

404LXR Series Product Manual

Effective: June 13, 2018
Supersedes: December 20, 2017



Electromechanical Positioning Systems



Important User Information



WARNING

FAILURE OR IMPROPER SELECTION OR IMPROPER USE OF THE PRODUCTS AND/OR SYSTEMS DESCRIBED HEREIN OR RELATED ITEMS CAN CAUSE DEATH, PERSONAL INJURY AND PROPERTY DAMAGE.

This document and other information from Parker Hannifin Corporation, its subsidiaries, and authorized distributors provide product and/or system options for further investigation by users having technical expertise. It is important that you analyze all aspects of your application and review the information concerning the product or system in the current product catalog. Due to the variety of operating conditions and applications for these products or systems, the user, through its own analysis and testing, is solely responsible for making the final selection of the products and systems and assuring that all performance, safety and warning requirements of the application are met.

The products described herein, including without limitation, product features, specifications, designs, availability and pricing, are subject to change by Parker Hannifin Corporation and its subsidiaries at any time without notice.

The information in the product manual, including any apparatus, methods, techniques, and concepts described herein, are the proprietary property of Parker Hannifin Corporation or its licensors, and may not be copied, disclosed, or used for any purpose not expressly authorized by the owner thereof.

Since Parker Hannifin Corporation constantly strives to improve all of its products, we reserve the right to change this product manual and equipment mentioned therein at any time without notice.

.....
• *For assistance contact:*
• Parker Hannifin Corporation
• 1140 Sandy Hill Road
• Irwin, PA 15642
• Phone: 724/861-8200
• 800/245-6903
• Fax: 724/861-3330
• E-mail: ddlcat@parker.com
• Web site: www.parkermotion.com
.....

404LXR Series Product Manual

Table of Contents

REVISION NOTES	4
CHAPTER 1 - INTRODUCTION	5
PRODUCT DESCRIPTION.....	5
UNPACKING	5
RETURN INFORMATION.....	6
REPAIR INFORMATION.....	6
WARNINGS AND PRECAUTIONS	6
SPECIFICATION CONDITIONS AND CONVERSIONS	7
ASSEMBLY DIAGRAMS	8
<i>Strip Seal Version</i>	8
<i>Hardcover Version</i>	9
CHAPTER 2 - 404LXR SERIES TABLE SPECIFICATIONS	10
ORDER NUMBER NOMENCLATURE	10
DIMENSIONAL DRAWINGS.....	10
DIMENSIONAL DRAWINGS.....	11
GENERAL TABLE SPECIFICATIONS.....	11
404LXR SERIES TECHNICAL DATA.....	17
<i>Force/Speed Charts</i>	17
<i>Clean Room Preparation</i>	18
ELECTRICAL SPECIFICATIONS	19
ELECTRICAL SPECIFICATIONS	19
CABLING AND WIRING DIAGRAMS.....	22
<i>Connector Pin Out and Extension Cable Wire Color Codes</i>	22
<i>OEM Cable Option</i>	24
CHAPTER 3 - HOW TO USE THE 404LXR	26
MOUNTING SURFACE REQUIREMENTS	26
MOUNTING METHODS	26
SIDE AND INVERTED MOUNTING CONCERNS.....	27
SETTING TRAVEL LIMIT SENSORS	27
SETTING HOME SENSOR.....	27
Z CHANNEL POSITION REFERENCE	28
GROUNDING / SHIELDING	28
CABLING	29
CHAPTER 4 - PERFORMANCE	30
ACCELERATION LIMITS.....	30
SPEED LIMITS	31
ENCODER ACCURACY AND SLOPE CORRECTION.....	31
THERMAL EFFECTS ON ACCURACY.....	33
THERMAL EFFECTS ON REPEATABILITY.....	34
CAUSES OF TEMPERATURE INCREASES	34
COMPENSATING FOR THERMAL EFFECTS.....	35
CHAPTER 5 - CONNECTING THE DRIVE / AMPLIFIER	36
DRIVE / AMPLIFIER CONNECTION	36
CHAPTER 6 - MAINTENANCE AND LUBRICATION	39
INTERNAL ACCESS PROCEDURE	39
SQUARE RAIL BEARING LUBRICATION.....	41
CABLE MANAGEMENT MODULE REPLACEMENT.....	41
LIMIT AND HOME SENSOR MODULE REPLACEMENT.....	43
APPENDIX A – UNDERSTANDING LINEAR MOTORS	44
THE LINEAR MOTOR CONCEPT	44
LINEAR MOTOR BENEFITS	44
SLOTLESS LINEAR MOTOR DESIGN	44
ADVANTAGES/DISADVANTAGES OF SLOTLESS LINEAR MOTORS	45
APPENDIX B - INTERNAL PROTECTION	46
INDEX	48

Revision Notes

Rev 3 April 11, 2003

Correction for Motor Wire 4 Pin Mat-N-Lok - p. 21

Limit and Home Sensor Module Adjustment Switch positions corrected. – p. 41

Rev 4 February 22, 2007

Update index page – p. 3

Changed Daedel Grease #1 to Multemp PS2 – p. 39

Removed Limit and Home Sensor Module Adjustment page from Chapter 6 (was page 41)

Updated connector release & torx screws. – p. 41

Rev 5 October 1, 2009

Added Aries and Compax3 Cable option – p. 23, 24

Updated Chapter 5 – Connecting the Drive / Amplifier to include Aries and Compax3 – p. 35

Rev 6 April 10, 2013

Clarified warnings to sync with CE risk assessments

P.5 Unpacking, p. 6 General Safety

Rev 7 February 16, 2017

Updated Cable Management Module part numbers Page 41

Rev H December 20, 2017

Removed references to ribbon cables

Rev J Added Compax options

Chapter 1 - Introduction

Product Description

404LXR Positioner

The 404LXR is a slotless, brushless linear servo motor/square rail bearing positioner housed within a high strength, extruded aluminum body with magnetically retained protective seals. The positioner is powered by a single rail of high energy rare earth magnets. Load bearing members provide heavy load and moment capacity, dynamic stiffness and precise straightness and flatness of travel. The positioner's integral linear encoder provides high precision, non-contact positional feedback with selectable resolutions from 0.1 to 5.0 microns. The positioner is also offered with inductive proximity limit & home sensors, a "Quick Connect", extended life, and a cable transport system.

Unpacking



Unpacking

Carefully remove the positioner from the shipping crate and inspect the unit for any evidence of shipping damage. Report any damage immediately to your local authorized distributor. Please save the shipping crate for damage inspection or future transportation.

Incorrect handling of the positioner may adversely affect the performance of the unit in its application. Please observe the following guidelines for handling and mounting of your new positioner.

- Product may be heavy. Standard handling and lifting practices should be employed.
- DO NOT allow the positioner to drop onto the mounting surface. Dropping the positioner can generate impact loads that may result in flat spots on bearing surfaces or misalignment of drive components.
- DO NOT drill holes into the positioner. Drilling holes into the positioner can generate particles and machining forces that may affect the operation of the positioner. Parker will drill holes if necessary; contact your local authorized distributor.
- DO NOT subject the unit to impact loads such as hammering, riveting, etc. Impacts loads generated by hammering or riveting may result in flat spots on bearing surfaces or misalignment of drive components.
- DO NOT lift the positioner by cables or cable management system. Lifting positioner by cables or cable management system may affect electrical connections and/or cable management assembly. The unit should be lifted by the base structure only.
- DO NOT push in magnetically retained strip seals when removing positioner from shipping crate. Damaging strip seals may create additional friction during travel and may jeopardize the ability of the strip seals to protect the interior of the positioner.
- DO NOT submerge the positioner in liquids.
- DO NOT disassemble positioner. Unauthorized adjustments may alter the positioner's specifications and void the product warranty.

Return Information

Returns

All returns must reference a "Return Material Authorization", (RMA), number. Please call your local authorized distributor or Parker Customer Service Department at 800-245-6903 to obtain a "RMA" number.

Repair Information

Out-of-Warranty Repair

Our Customer Service Department repairs Out-of-Warranty products. All returns must reference a "RMA" number. Please call your local authorized distributor or Parker Customer Service Department at 800-245-6903 to obtain a "RMA" number. You will be notified of any cost prior to making the repair.

Warnings and Precautions



Hot Surfaces

DO NOT touch 'carriage forcer', (see page 7, *Assembly Diagram*, for component location), after high duty operation. Unit *may* be too HOT to handle.



Electrical Shock

DO NOT take apart or touch any internal components of the positioner while unit is plugged into an electrical outlet. SHUT OFF power before replacing components to avoid electrical shock.



High Magnetic Field

Unit may be HAZARDOUS to people with Pace Makers or any other 'magnetically-sensitive' medical devices. Unit may have an effect on 'magnetically-sensitive' applications.



Ferrous Materials

The positioner's 'protective seals' MAY NOT keep out all small ferrous materials in applications with air born metallic particles. The customer must take additional precautions in these applications to keep positioner free of these highly magnetic particles.



Vertical Operation

The 404LXR is NOT recommended for vertical operation. The carriage and customer's load will fall in power loss situations potentially causing product damage or personal injury.



General Safety

Because linear motors can accelerate up to 5 g's, and sometimes positioners move without warning, keep all personnel away from dynamic travel range of positioner.

Specification Conditions and Conversions

Specifications are Temperature Dependent

Catalog specifications are obtained and measured at 20 Degrees C. Specifications at any other temperature may *deviate* from catalog specifications. Minimum to maximum continuous operating *temperature range* (with NO guarantee of any specification except motion) of a standard unit before failure is 5 - 40 Degrees C.

Specifications are Mounting Surface Dependent

Catalog specifications are obtained and measured when the positioner is *fully supported, bolted down* (to eliminate any extrusion deviation), and is mounted to a work surface that has a *maximum flatness error of 0.013mm/300mm (0.0005"/ft)*.

Specifications are Point of Measurement Dependent

Catalog specifications and specifications in this manual are measured from the center of the carriage, 38 mm above the carriage surface. All measurements taken at any other location may deviate from these values.

Assembly Diagrams

Strip Seal Version

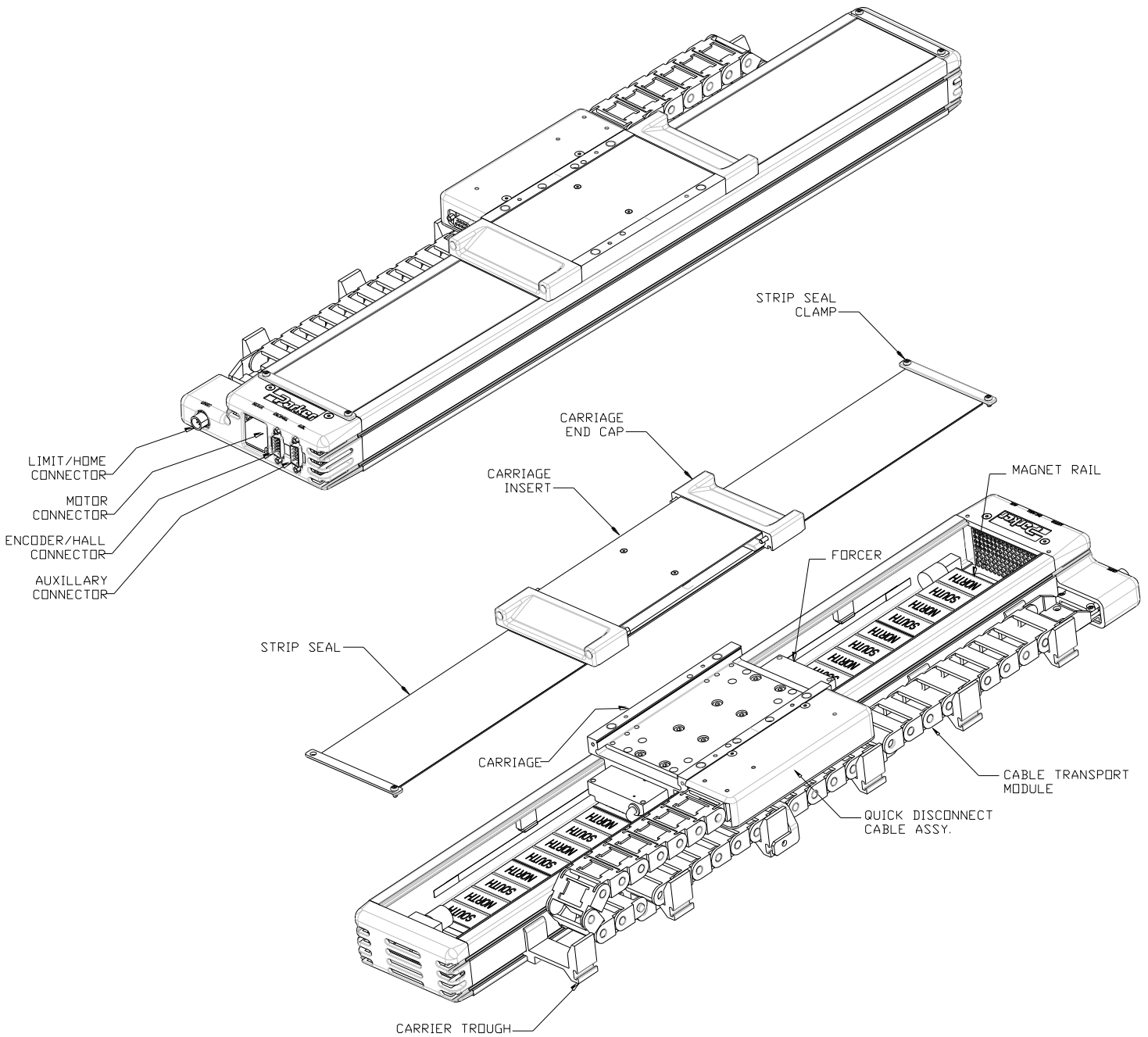

Hardcover Version

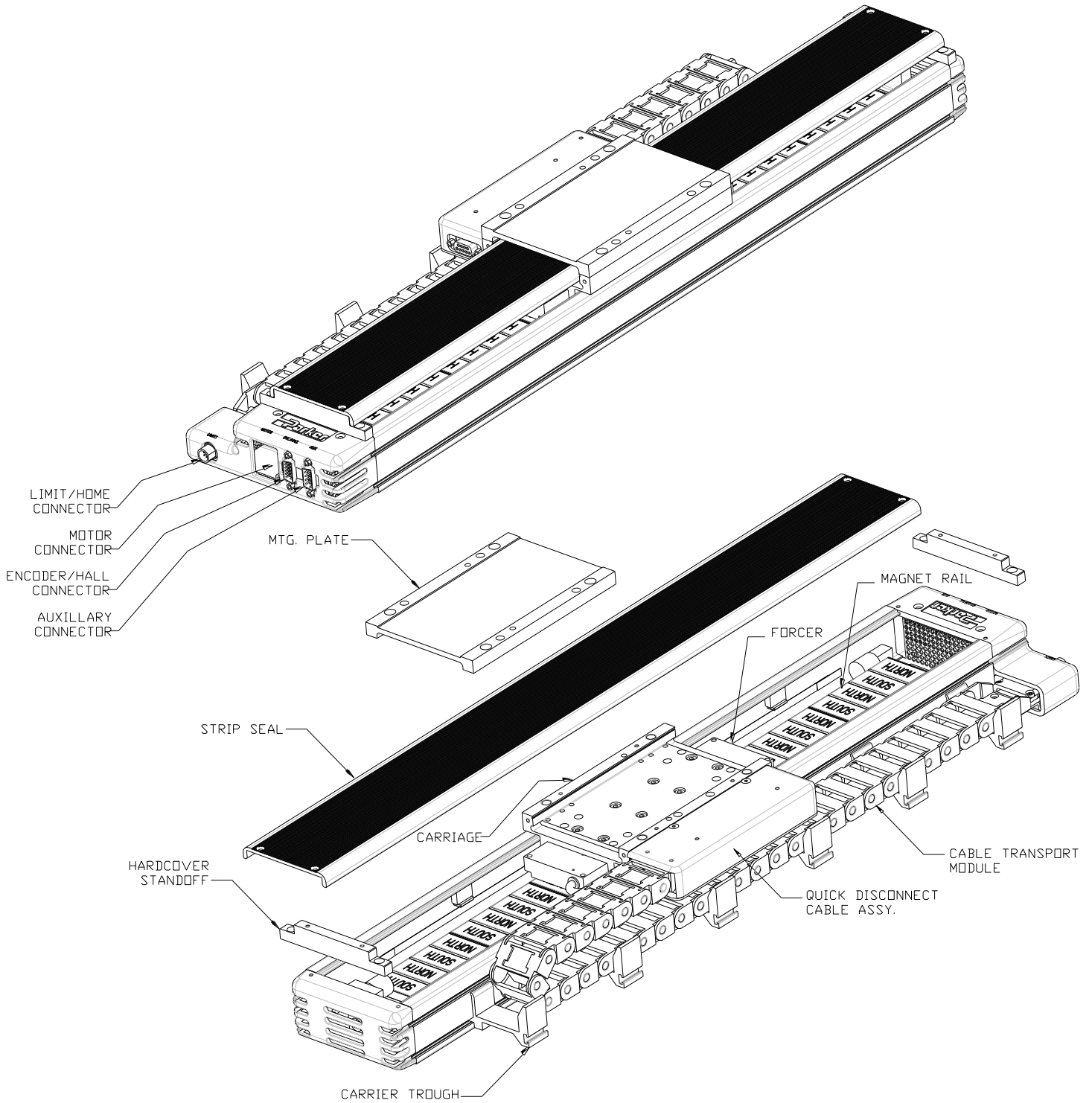

Chapter 2 - 404LXR Series Table Specifications

Order Number Nomenclature

Order Example:	①	②	③	④	⑤	⑥	⑦	⑧	⑨	⑩	⑪	⑫	⑬	⑭
	404	T04	LXR	M	P	D13	H3	L2	CM09	Z2	E2	R1	A4	P1

- ① **Series**
404
- ② **Travel – mm**
8 Pole Motor
T00 50
T01 100
T02 150
T03 200
T04 250
T05 300
T06 350
T07 400
T09 500
T11 600
T13 700
T15 800
T17 900
T19 1000
- ③ **Model**
LXR Linear Motor
- ④ **Mounting**
M Metric
- ⑤ **Grade**
P Precision
- ⑥ **Drive Type**
D3 Free Travel (No Motor)
D13 8 Pole Motor
- ⑦ **Home Sensor**
H1 None-Free Travel (only)
H2 N.C. Current Sinking
H3 N.O. Current Sinking
H4 N.C. Current Sourcing
H5 N.O. Current Sourcing
- ⑧ **Limit Sensor**
L1 None-Free Travel (only)
L2 N.C. Current Sinking
L3 N.O. Current Sinking
L4 N.C. Current Sourcing
L5 N.O. Current Sourcing

- ⑨ **Cable Management**
CM01 No Cables – Free Travel
CM02 Cable Transport Module (only)
CM03 3.0 m OEM Cable Set-FL
CM04 7.5 m OEM Cable Set-FL
CM05 3.0 m OEM Cable Set-Gemini
CM06 7.5 m OEM Cable Set-Gemini
CM07 Cable Trans Mod. w/3.0 m-FL*
CM08 Cable Trans Mod. w/7.5 m-FL*
CM09 Cable Trans Mod. w/3.0 m-Gemini*
CM10 Cable Trans Mod. w/7.5 m-Gemini*
CM11 3.0 m OEM Cable Set-Aries/ViX
CM12 7.5 m OEM Cable Set-Aries/ViX
CM13 Cable Trans Mod. w/3.0 m-Aries/ViX*
CM14 Cable Trans Mod. w/7.5 m-Aries/ViX*
CM15 3.0 m OEM Cable Set-Compax3**
CM16 7.5 m OEM Cable Set-Compax3**
CM17 Cable Trans Mod. w/3.0 m-Compax3* & **
CM18 Cable Trans Mod. w/7.5 m-Compax3* & **

* Extension cable for pass through connection is available and can be ordered separately:
#006-1743-01 (3 meters); #006-1743-02 (7.5 meters)
** When wiring to a Compax3 please select current sourcing sensors
- ⑩ **Z Channel Location***
Z1 None
Z2 Positive End Position
Z3 Center Position
Z4 Negative End Position
- ⑪ **Encoder Option**
E1 None
E2 1.0 µm Resolution
E3 0.5 µm Resolution
E4 0.1 µm Resolution
E5 5.0 µm Resolution
E7 Sine Output Encoder
- ⑫ **Environmental**
R1 Strip Seal
R2 Hard Cover w/Class 10 Cleanroom Prep
R3 Hard Cover without Cleanroom Prep
- ⑬ **Digital Drive**
A1 No Drive
A4 Gemini Drive GV-U6E
A5 Gemini Controller/Drive GV6-U6E
A6 Gemini Controller/Drive GV6K-U6E
A62 Aries Drive AR-04AE
- ⑭ **Pinning Option**
P1 No multi-axis pinning
P2 * X axis transfer pinning to Y or Z axis - 30 arc-sec
P3 * Y axis transfer pinning to X axis - 30 arc-sec

Dimensional Drawings

404LXR Series Dimensions (mm)

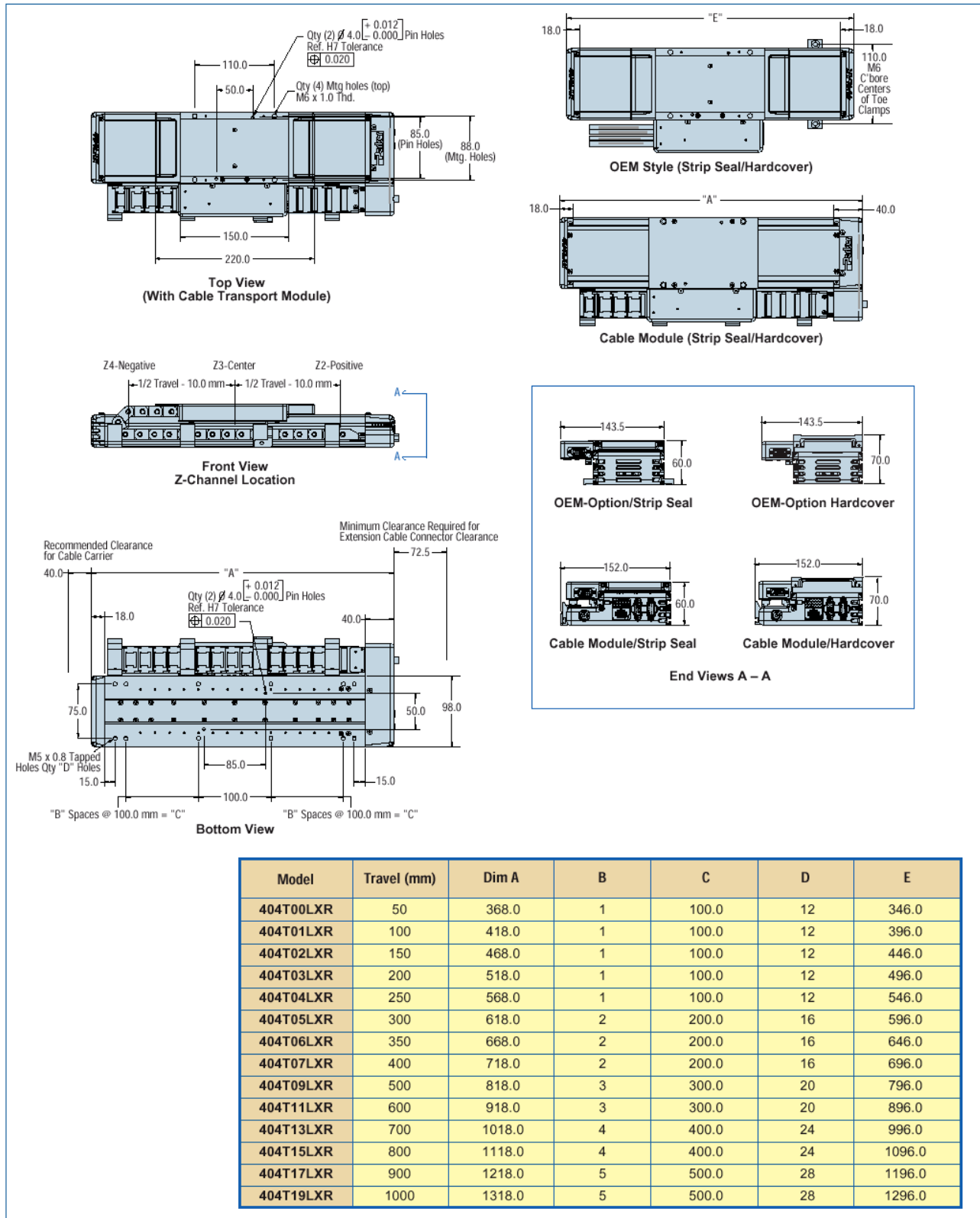

General Table Specifications

Specifications

Motor Model	8 Pole
Rated Load	45 kg
Maximum Acceleration	5 Gs
Maximum Velocity	
Resolution: 0.1 μ m	0.3 m/sec
0.5 μ m	1.5 m/sec
1.0 μ m	3.0 m/sec
5.0 μ m	3.0 m/sec
Positional Repeatability	
Resolution: 0.1 μ m	+/- 1.0 μ m
0.5 μ m	+/- 1.0 μ m
1.0 μ m	+/- 2.0 μ m
5.0 μ m	+/- 10.0 μ m
Maximum Force (Peak)	180 N 40 lb.
Maximum Force (Continuous)	50 N 11 lb.
Carriage Weight	1.4 kg

Travel Dependent Specifications

Travel (mm)	Accuracy*			Strip Seal Version Unit Weight (kg)	Hard Cover Version Unit Weight (kg)
	Positional		Straightline Accuracy* (μ m)		
	0.1, 0.5, 1.0 resolution (μ m)	5.0 resolution (μ m)			
50	6	16	6	4.4	4.4
100	7	17	7	4.8	4.9
150	8	18	9	5.2	5.4
200	10	20	11	5.6	5.8
250	12	22	14	6.0	6.3
300	14	24	17	6.4	6.7
350	16	26	19	6.8	7.2
400	18	28	22	7.2	7.6
500	21	31	26	8.0	8.6
600	25	35	31	8.9	9.5
700	28	38	35	9.7	10.5
800	31	41	39	10.6	11.4
900	33	44	43	11.5	12.5
1000	35	45	47	12.4	13.6

* Accuracy stated is at 20 degrees C, utilizing slope correction factor provided.

404LXR Series Technical Data

The useful life of a linear table at full catalog specifications is dependent on the forces acting upon it. These forces include both static components resulting from payload weight, and dynamic components due to acceleration/deceleration of the load. In multi-axes applications, the primary positioner at the bottom of the stack usually establishes the load limits for the combined axes. When determining load/life, it is critical to include the weight of all positioning elements that contribute to the load supported by the primary axis. The life/load charts are used to establish the table life relative to the applied loads.

Table Load Chart

The "Table Load" chart is intended to provide a rough-cut evaluation "life/load" characteristics of the carriage support bearings. This curve is based on the applied load being centered on the carriage, normal to the carriage mounting surface.

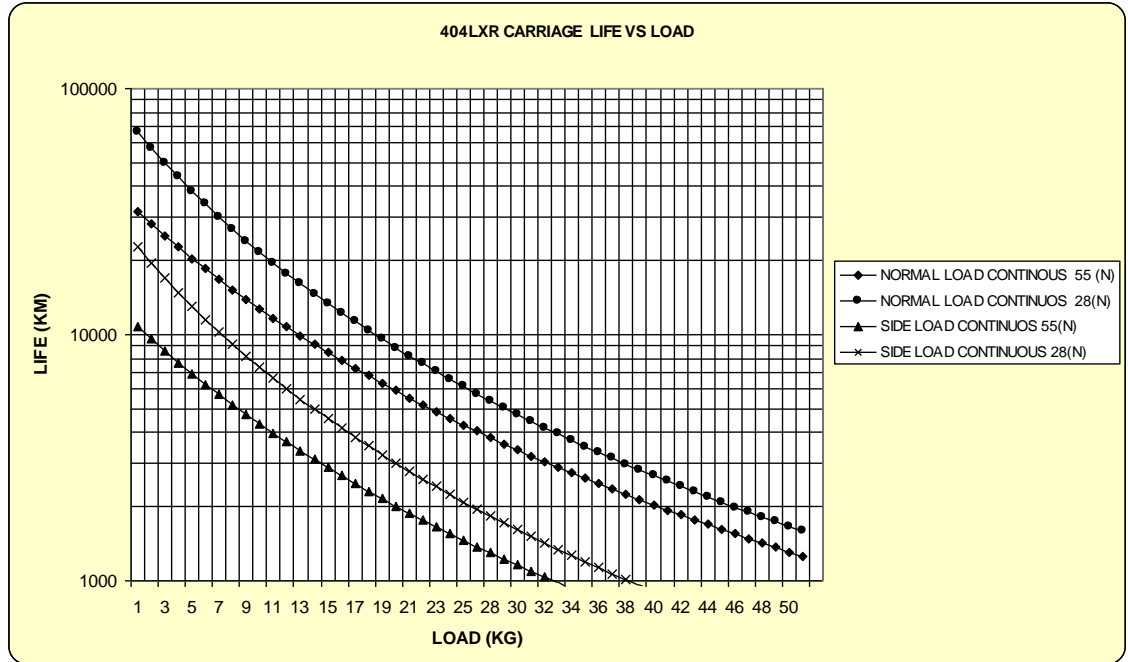

Bearing Load Chart

The "Bearing Load" chart is to be used in conjunction with the corresponding formulas on the following pages to establish the life/load for each bearing (4 per table). Several dimensions and the load geometry are required for these computations. The dimensions are referenced below.

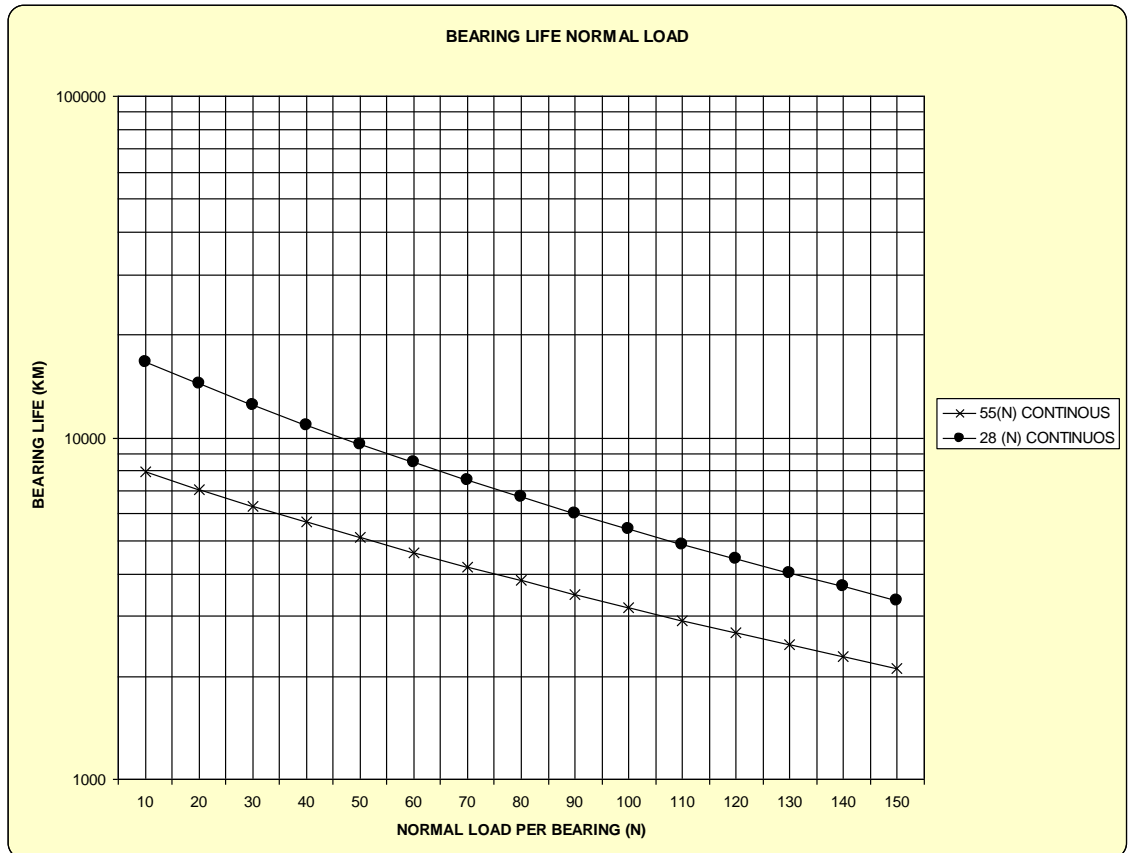

Side Bearing Load Chart

The "Side Bearing Load" chart is to be used in conjunction with the corresponding formulas on the following pages to establish the life/load for each bearing (4 per table). Several dimensions and the load geometry are required for these computations. The dimensions are referenced below.

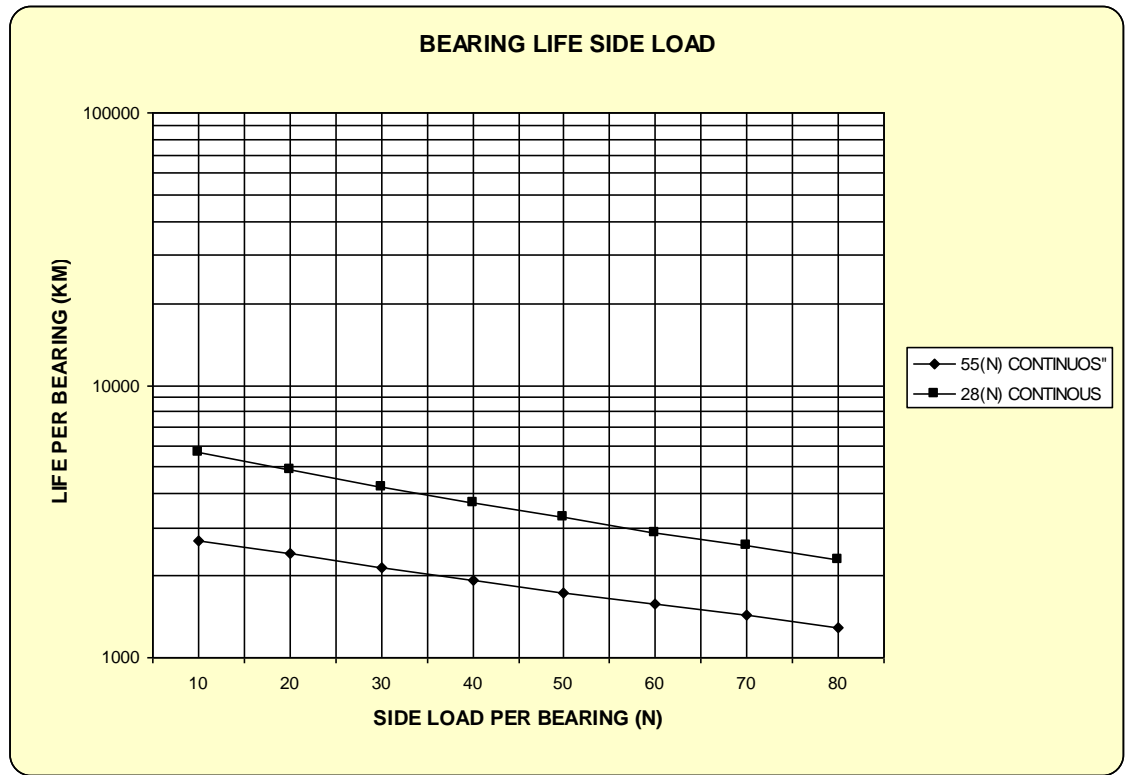

Note: 55 (N) continuous is the life rating if the table is operated with a motor thrust force of 55 Newtons (RMS). The reason that continuous motor force effects bearing life is due to forces applied to the bearing caused by thermal expansion of the carriage. The 28 (N) rating is the life if only 28 Newtons (RMS) is used.

	d1	d2	da
Strip Seal Model	108.5	60.0	48.5
Hardcover Model	108.5	60.0	53.5

Horizontal Translation — Normal Load

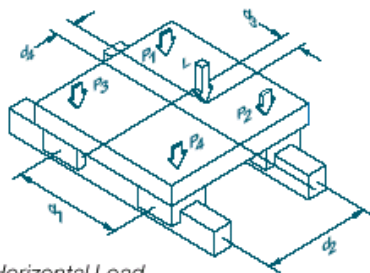

Figure 1: Horizontal Load

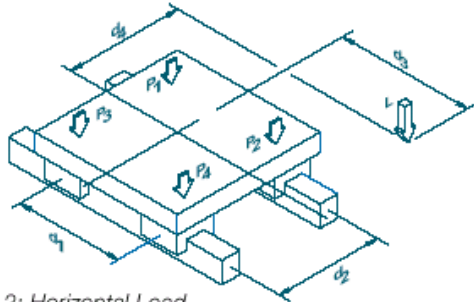

Figure 2: Horizontal Load

$$P_1 = \left[\frac{L}{4} - \left[\frac{L}{2} \cdot \frac{d_3}{d_1} \right] + \left[\frac{L}{2} \cdot \frac{d_4}{d_2} \right] \right]$$

$$P_2 = \left[\frac{L}{4} + \left[\frac{L}{2} \cdot \frac{d_3}{d_1} \right] + \left[\frac{L}{2} \cdot \frac{d_4}{d_2} \right] \right]$$

$$P_3 = \left[\frac{L}{4} - \left[\frac{L}{2} \cdot \frac{d_3}{d_1} \right] - \left[\frac{L}{2} \cdot \frac{d_4}{d_2} \right] \right]$$

$$P_4 = \left[\frac{L}{4} + \left[\frac{L}{2} \cdot \frac{d_3}{d_1} \right] - \left[\frac{L}{2} \cdot \frac{d_4}{d_2} \right] \right]$$

Figure 1 shows a normal load applied to the carriage translating horizontally. The vector L, defined by the CG of the load, is shown applied at a point whose coordinate distances from the center of the carriage are given by distances d3 and d4.

With the positioner at rest or moving with uniform velocity, the loads on each of the four bearing blocks are given by the above equations:

Note that each of the four bearing blocks will experience

either compressional or tensional loading; the magnitude of these forces at each bearing is dependent upon the location of the load vector with respect to the center of the positioner carriage. For each bearing, the maximum of the forces in tension and compression is plotted on the load charts for the specific model positioner to determine the life of the table in the application.

The calculations for loads whose CG falls outside the carriage mounting surface area, as shown in Figure 2, are identical to those used with Figure 1. In either case, accelerations and decelerations of the load must be considered in calculating the dynamic forces which determine the life of the system in a particular application.

Horizontal Translation — Side Load

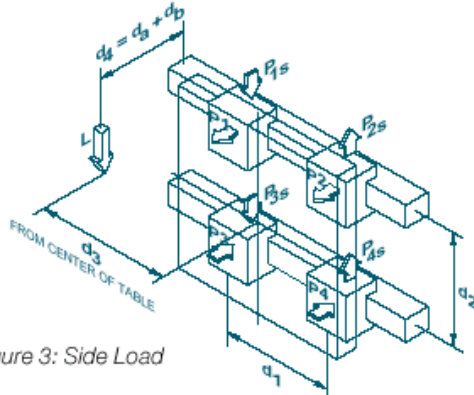

Figure 3: Side Load

The previous loading scenarios have involved only normal forces (compressional or tensional) on the bearings. Consider a positioner as shown in Figure 3, which involves a lateral (side) load applied to the carriage which translates horizontally. The load vector (L) is shown applied at a point whose coordinate distances from the center of the carriage bearing system are given by dimensions d3 and d4. Note that d4 is the sum of distance da—the distance between bearing and center and

carriage surface which is provided for each linear positioner—plus db, the distance of the load CG from the mounting surface of the carriage.

The loading felt by each of the four bearing blocks when the positioner is stationary or moving with uniform velocity is given by the above equations:

Here P1, P2, P3 and P4 are the normal loads (tensional and compression) and P1S, P2S, P3S and P4S are the side loads. For each

$$P_1 = P_2 = \frac{L}{2} \left[\frac{d_4}{d_2} \right]$$

$$P_3 = P_4 = - \frac{L}{2} \left[\frac{d_4}{d_2} \right]$$

$$P_{1s} = P_{3s} = \frac{L}{4} + \left[\frac{L}{2} \cdot \frac{d_3}{d_1} \right]$$

$$P_{2s} = P_{4s} = \frac{L}{4} - \left[\frac{L}{2} \cdot \frac{d_3}{d_1} \right]$$

bearing, the largest side loads and normal loads in both tension and compression are identified for calculating the positioner life in the application.

For round rail/ball bushing type bearings, the forces are plotted individually on the appropriate curves to determine the service life.

For linear motion guide bearing positioners, an “equivalent load per bearing” is calculated for the life determination. Equations listed in Table A, page 22,

apply for the Daedal positioners which incorporate linear motion guide bearings. As shown in Table A, this “equivalent load” is plotted on the indicated load/life graph to determine the positioner’s service life.

Again, accelerations and decelerations of the load must be considered in calculating the dynamic forces which determine the life of the system in a particular application.

Table A – Linear Motion Guide Bearing Life/Load Computation

Positioner	Loads	Compute	Evaluate Life On
404LXR	Side & tension $P_s > P_t$ Side & tension $P_s \leq P_t$	$P_e = (0.5 \times P_t) + P_s$ $P_e = (0.5 \times P_s) + P_t$	Side load chart Tension chart
	Side & compression $P_s > P_c$ Side & compression $P_s \leq P_c$	$P_e = (0.5 \times P_c) + P_s$ $P_e = (0.5 \times P_s) + P_c$	Side load chart Compression chart

Example Computations

Example 1

Page 14 shows this configuration with dimensions given here.
Horizontal Translation with Side Loads, 404LXR-8 Pole Positioner

$L = 10$ Kgf
130 mm from carriage surface;
50 mm from carriage center.

$d_1 = 108.5$ mm

$d_b = 130$ mm

$d_2 = 60.0$ mm

$d_3 = 50$ mm

$d_a = 48.5$ mm

$d_4 = d_a + d_b = 178.5$

The normal and side force components on each bearing block are computed from the equations as shown:

$$P_1 = P_2 = \frac{L}{2} \left[\frac{d_4}{d_2} \right] = 14.9 \text{ (tension) Kgf}$$

$$P_3 = P_4 = -\frac{L}{2} \left[\frac{d_4}{d_2} \right] = -14.9 \text{ (compression) Kgf}$$

$$P_{1s} = P_{3s} = \frac{L}{4} + \left[\frac{L}{2} \cdot \frac{d_3}{d_1} \right] = 4.8$$

$$P_{2s} = P_{4s} = \frac{L}{4} - \left[\frac{L}{2} \cdot \frac{d_3}{d_1} \right] = -0.2$$

Life for each bearing needs to be evaluated independently. For bearings with a side load, refer to the combined equivalent loading factors (Table A above).

Example:

Bearing 3 had $P_3 = 5.6$ Kgf tension and $P_{3s} = 2.7$ Kgf side load

$$P_s \leq P_c \Rightarrow P_e = (0.5 \times P_s) + P_c = 7 \text{ Kgf}$$

Refer to Bearing Life Normal Load (page 12)
Life @ 7 Kgf (69 Newtons) = 4200 km

404LXR Series Technical Data

Force/Speed Charts

The chart on this page illustrates the characteristics of the 404LXR linear motor. The force/speed chart shows the characteristics of the motor with either a 170 VDC or 340 VDC bus voltage.

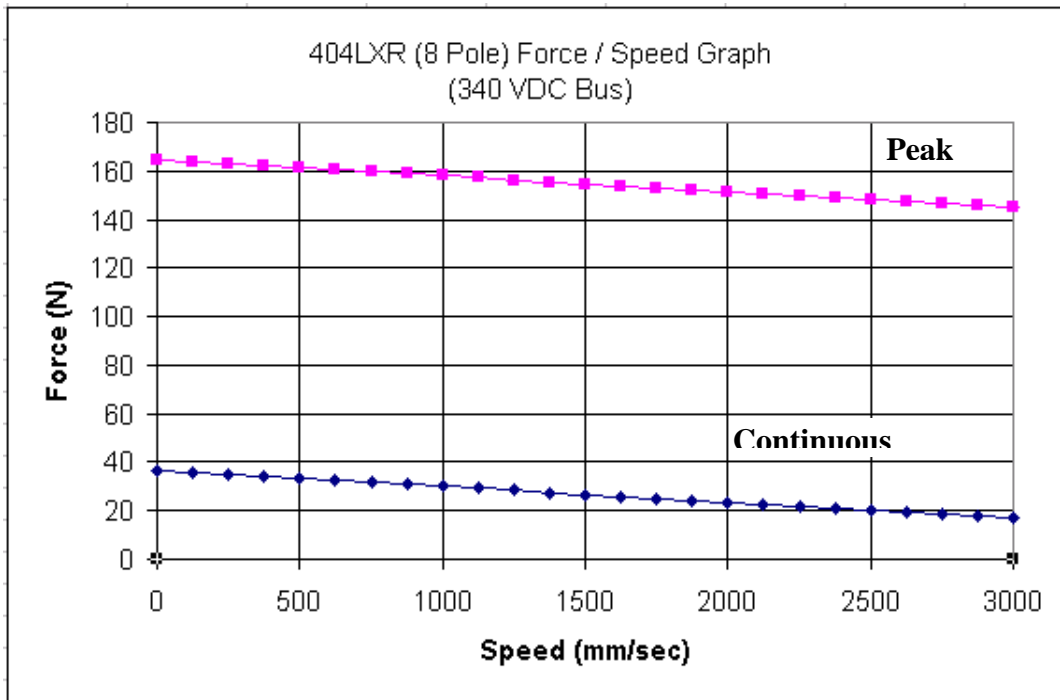
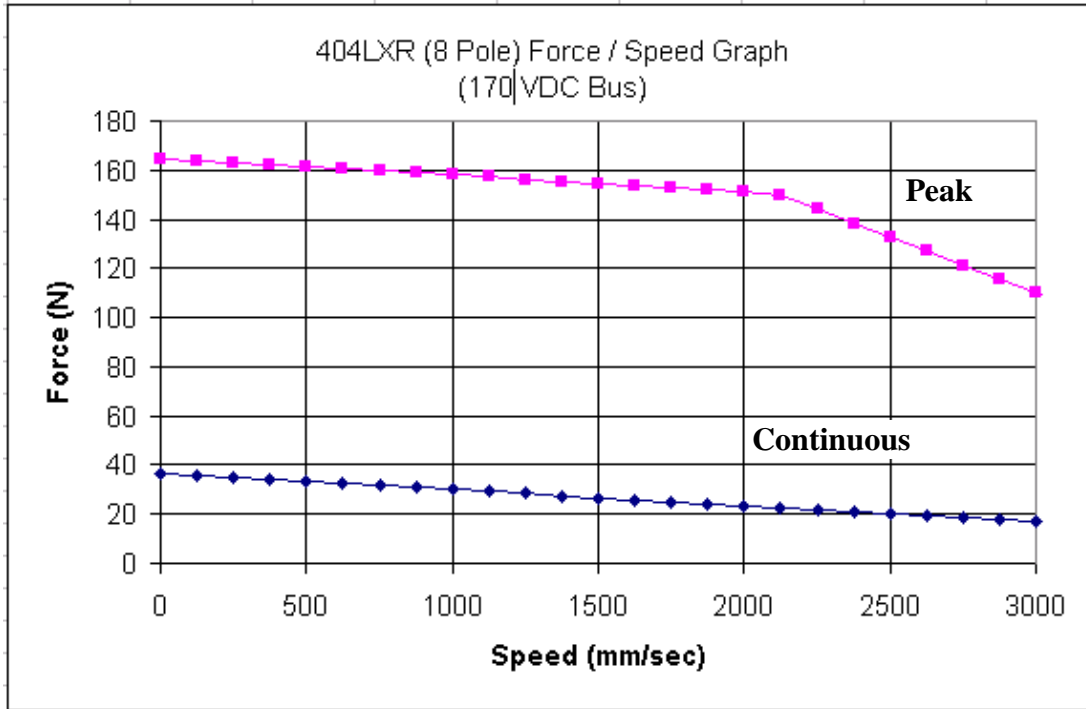

Clean Room Preparation

404LXR tables with clean room preparation were tested in Parker’s vertical laminar flow work station which utilizes ULPA filters to produce an environment having a cleanliness of class 1 prior to testing. Tables were tested in a variety of orientations with sampling both below the table and at the carriage mounting surface. Laminar flow rate is 0.65 inches W.C.

Standard Clean Room Preparation

- Stringent cleaning and handling measures**
- Clean room rated lubricant**
- Strip seal replaced with hard shell cover**

400LXR Clean Room Compatability

Table Velocity	Class	
	4.5" below table	At carriage surface
250 mm/sec	10	1
500 mm/sec	25	1
1000 mm/sec	50	5
2000 mm/sec	250	25
3000 mm/sec	500	100

About Clean Rooms

A room in which the concentration of airborne particles is controlled within defined limits. Federal Standard 209E statistically defines the allowable number of particles per cubic foot of air.

The chart (right) describes the conditions that must be maintained for the cleanroom to have a specific “class” rating.

Class	Number of Allowable Particles				
	0.1	0.2	0.3	0.5	5
1	35	7.5	3	1	n/a
10	350	75	30	10	n/a
100	n/a	750	300	100	n/a
1000	n/a	n/a	n/a	1000	7
10000	n/a	n/a	n/a	10000	70
100000	n/a	n/a	n/a	100000	700

Electrical Specifications

Parameter	8 Pole	Units
Continuous Force ₁	50	N
Continuous Current _{1,4,8}	2.3	Amps Peak
Continuous Current _{1,7}	2.0	Amps DC
Peak Force ₆	180	N
Peak Current _{4,6,8}	8.3	Amps Peak
Peak Current _{6,7}	7.2	Amps DC
Voltage Constant _{3,4}	25.15	Volt/m/sec
Force Constant ₉	21.78	N/Amps Peak
Force Constant _{3,4}	25.15	N/Amps DC
Resistance ₃	10.2	Ohms
Inductance ₅	2.63	mH
Maximum Bus Voltage	340	Volts DC
Thermal Resist. Winding-Ambient	1	C/watt
Viscous Damping	6.3	N/m/s
Static Friction ₁₃	15	N
Intermit Force Duration ₁₀	12	Seconds
Peak Force Duration ₁₁	5	Seconds
Magnetic Attraction ₂	280	N
Electrical Pitch ₁₂	42	mm
Mass-Motor Carriage	1.5	Kg
Rated Winding Temp.	90	C/watt
Winding Class	H	-

1. @ 25° C ambient, 90° C winding temperature
2. Measured with a 0.70 mm gap
3. Measured line to line +/-10%
4. Value is measured peak of sine
5. +/-30% line to line, inductance bridge measurement @ 1Khz
6. Initial winding temperature must be 60° C or less before peak current is applied
7. DC current through a pair of motor phases of a trapezoidal (six state) commutated motor
8. Peak of the sinusoidal current in any phase for a sinusoidal commutated motor
9. Total motor force per peak of the sinusoidal amps measured in any phase, +/-10%
10. Maximum time duration with 2 times rated current applied with initial winding temperature at 60° C
11. Maximum time duration with 3 times rated current applied with initial winding temperature at 60° C
12. The distance from the leading edge of the north pole to the leading edge of the next north pole
13. Average friction over total table travel

Encoder Specifications

Description	Specification
Input Power	5 VDC +/-5% 150 mA
Output (Incremental)	Square wave differential line driver (EIA RS422) 2 channels A and B in quadrature (90) phase shift.
Reference (Z Channel)	Synchronized pulse, duration equal to one resolution bit. Repeatability of position is unidirectional moving toward positive direction.
Maximum Speed	5.0 micron resolution = 3.0 meters/sec 1.0 micron resolution = 3.0 meters/sec 0.5 micron resolution = 1.5 meters/sec 0.1 micron resolution = 0.3 meters/sec

Hall Effect Specification

Description	Specifications
Input Power	+5 to +24 VDC, 30 mA
Output	Open collector, Current Sinking, 20 mA Max

Gemini Drive Specifications

Description	Specification
Drive Input Power	
Voltage	96-265 VAC
Phase	1Ø
Frequency	50/60 Hz
24V Keep Alive (Optional)	24 VDC – 20%
Drive Output Power	
Bus Voltage	170 or 340 VDC
Switching Frequency	8 or 16 kHz
Continuous Current	4.5 Amps
Peak Current	11.25 Amps
Commutation	Sinusoidal
Command Inputs	
Velocity and Torque	+/-10V
Position Mode	Step & Direction or CW & CCW
Encoder Track Mode	Allows post quadrature encoder to be used as command signals
Inputs	
Enable (Required)	0-24 VDC
Reset	
Pos/Neg Limits	
User Faults	
Outputs	
Fault	Open collector, 300 mA sink capability
At Limit	Open collector, 300 mA sink capability
Position Error	Open collector, 300 mA sink capability
Analog Monitors	+/-10V scalable, 8 bit (not to be used as control functions)
Relay	Normally open, dry contact
Communications	
Type	RS232/RS485 (4 wire)
Baud Rate	Fixed at 9600
Daisy Chain	Up to 98
Environmental	
Temperature	Still air 32°F (0°C)-113°F (46°C), moving air: 32°F (0°C)-122°F (50°C)
Humidity	0–95%, non-condensing
Shock/Vibration	Shock: 15G half-sign @ 11 msec/vibration: 2G, 10-2000 Hz
Protection	

Short Circuit	Phase-to-phase, phase-to-ground
Brownout	AC drops below 85 VAC
Over Temperature	Shutdown fault at 131°F (55°C)
Standards	UL, cUL, CE (LVD), CE (EMC)

Limit and Home Sensor Specifications

Description	Specification
Input Power	+5 to +24 VDC 60 mA
Output	Output form is selectable with product: Normally Closed Current Sinking Normally Open Current Sourcing Normally Closed Current Sourcing Normally Open Current Sourcing All types Sink or Source maximum of 50 mA
Repeatability	Limits: +/- 5 microns (unidirectional) Home: See Z channel specifications

Cabling and Wiring Diagrams

Connector Pin Out and Extension Cable Wire Color Codes

Cable Module Transport Wiring

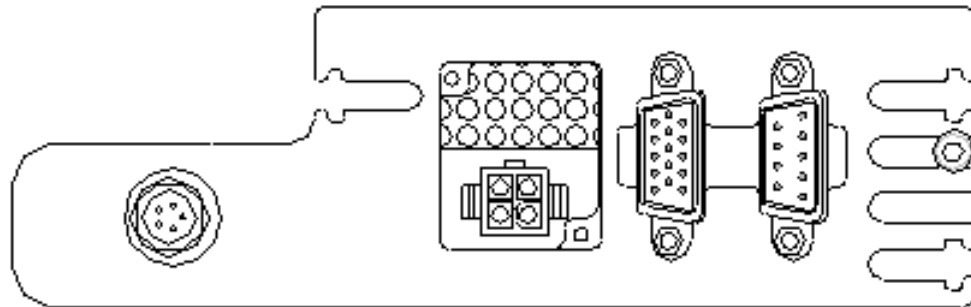

Limit/Home
5 Pin Connector



- A. +5 to +24 VDC
- B. Negative Limit
- C. Positive Limit
- D. Home
- E. Ground

Motor Wires
4 Pin Mat-N-Lok

Looking at connector on Cable Module

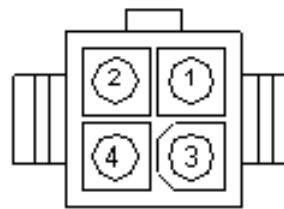

- 1. Phase A
- 2. Phase B
- 3. Phase C
- 4. Ground

Encoder Halls
15 Pin D-Connector

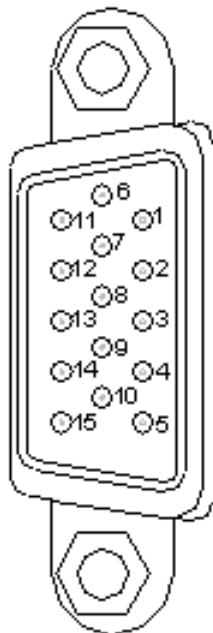

- 1. +5 VDC
- 2. Ch A+
- 3. Ch A-
- 4. Ch B+
- 5. Ch B-
- 6. Ch Z+
- 7. Ch Z-
- 8. Ground
- 9. +5 VDC Hall
- 10. Hall 1
- 11. Hall 2
- 12. Hall 3
- 13. Temp
- 14. Temp
- 15. Ground

Auxillary
9 Pin D-Connector

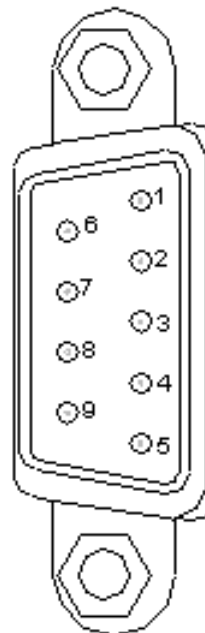

- 1. User Defined
- 2. User Defined
- 3. User Defined
- 4. User Defined
- 5. User Defined
- 6. User Defined
- 7. User Defined
- 8. User Defined
- 9. User Defined

Extension Cable Motor Connections

Function	Cable Wire Color	404LXR Connector Female
Phase A	Black #1	1
Phase B	Black #2	2
Phase C	Black #3	3
Ground	Green/Yellow	4
Shield	Shield	Shield Case

Extension Cable Encoder Connections

Function	Cable Wire Color	404LXR High Density 15 Pin "D" Connector
+ 5VDC	Red	1
Ch A+	White	2
Ch A-	Yellow	3
Ch B+	Green	4
Ch B-	Blue	5
Ch Z+	Orange	6
Ch Z-	Brown	7
Ground	Black	8
+5 VDC (Hall)	White/Blue	9
Hall 1	White/Brown	10
Hall 2	White/Orange	11
Hall 3	White/Violet	12
Temp	Yellow/Orange	13
Temp	Yellow/Orange	14
Ground	White/Green	15
Shield	Green/Yellow Stripe	Shield Cover

Extension Cable Limit and Home Connections

Function	Cable Wire Color	404LXR Connector Male 5 Pin Connector
+ 5 to +24 VDC	Red	A
Negative Limit	Blue	B
Positive Limit	Orange	C
Home	Green	D
Ground	Black	E
Shield	Shield	Shield Case

Extension Cable Auxiliary Connections

Function	Cable Wire Color	404LXR Connector Female 9 Pin "D" Connector
User Defined	Red	1
User Defined	Blue	2
User Defined	White	3
User Defined	Yellow	4
User Defined	Orange	5
User Defined	Green	6
User Defined	Purple	7
User Defined	Brown	8
User Defined	Black	9
User Defined	Shield	Shield Cover

OEM Cable Option

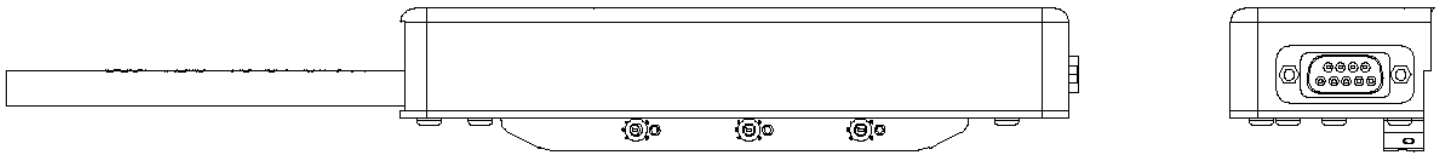
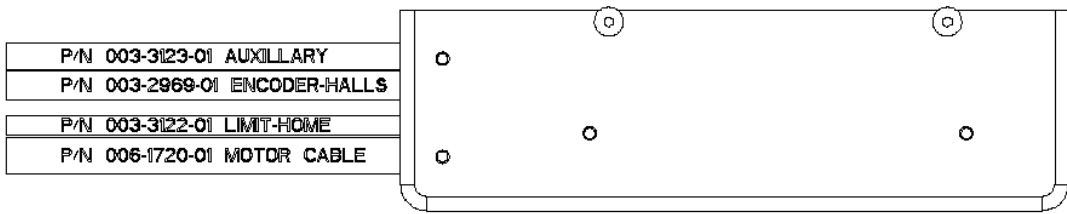

OEM Motor Flying Leads

Function	Cable Wire Color
PHASE A	BLACK #1
PHASE B	BLACK #2
PHASE C	BLACK #3
GROUND	GREEN/YELLOW

OEM Encoder Flying Leads

Function	Cable Wire Color
+5	RED
GROUND	BLACK
A+	WHITE
A-	YELLOW
B+	GREEN
B-	BLUE
Z+	ORANGE
Z-	BROWN
TEMP	YELLOW/ORANGE
TEMP	YELLOW/ORANGE
+5 HALL	WHITE/BLUE
GROUND	WHITE/GREEN
HALL 1	WHITE/BROWN
HALL 2	WHITE/ORANGE
HALL 3	WHITE/VIOLET
SHIELD	GREEN/YELLOW

OEM Gemini Encoder Connector

Function	Cable Wire Color	Pin #
+5	RED	1
GROUND	BLACK	3
A+	WHITE	5
A-	YELLOW	6
B+	GREEN	7
B-	BLUE	8
Z+	ORANGE	9
Z-	BROWN	10
TEMP	YELLOW/ORANGE	12
TEMP	YELLOW/ORANGE	13
+5 HALL	WHITE/BLUE	14
GROUND	WHITE/GREEN	15
HALL 1	WHITE/BROWN	16
HALL 2	WHITE/ORANGE	17
HALL 3	WHITE/VIOLET	18
SHIELD	SHIELD	SHIELD CASE

OEM Aries Encoder Connector

Function	Cable Wire Color	Pin #
Z+	ORANGE	1
Z-	BROWN	2
GROUND	BLACK	3
		4
+5	RED	5
TEMP-	YELLOW/ORANGE	6
B-	BLUE	7
B+	GREEN	8
HALL 1	WHITE/BROWN	9
TEMP+	YELLOW/ORANGE	10
A+	WHITE	11
A-	YELLOW	12
HALL 2	WHITE/ORANGE	13
HALL 3	WHITE/VIOLET	14
		15
SHIELD	SHIELD	SHIELD CASE
GROUND	WHITE/GREEN	JUMPED TO 3
+5 HALL	WHITE/BLUE	JUMPED TO 5

OEM Compax3 Encoder Connector

Function	Cable Wire Color	Pin #
SENSE-	WHITE/GREEN	1
SENSE+	WHITE/BLUE	2
HALL 1	WHITE/BROWN	3
+5	RED	4
TEMP+	YELLOW/ORANGE	5
HALL 2	WHITE/ORANGE	6
A-	YELLOW	7
A+	WHITE	8
HALL 3	WHITE/VIOLET	9
TEMP-	YELLOW/ORANGE	10
B-	BLUE	11
B+	GREEN	12
Z+	ORANGE	13
Z-	BROWN	14
GROUND	BLACK	15
SHIELD	SHIELD	SHIELD CASE

OEM Gemini and Aries Limit and Home Connections

Function	Cable Wire Color (Flying Leads)
5-24 VDC	RED
+ LIMIT	ORANGE
- LIMIT	BLUE
HOME	GREEN
GROUND	BLACK
SHIELD	GREEN/YELLOW

OEM Compax3 Limit and Home Connector

Function	Cable Wire Color	Pin #
+24 VDC	RED	1
+ LIMIT	ORANGE	12
- LIMIT	BLUE	13
HOME	GREEN	14
GROUND	BLACK	15
SHIELD	SHIELD	SHIELD CASE

OEM Auxiliary Cable

Function	Cable Wire Color (Flying Leads)
USER DEFINED	RED
USER DEFINED	BLUE
USER DEFINED	WHITE
USER DEFINED	YELLOW
USER DEFINED	ORANGE
USER DEFINED	GREEN
USER DEFINED	VIOLET
USER DEFINED	BROWN
USER DEFINED	BLACK
SHIELD	GREEN/YELLOW

Chapter 3 - How to Use the 404LXR

Mounting Surface Requirements

Proper mounting of the 404LXR is essential to optimize product performance. All specifications are based on the following conditions:

- The positioner must be bolted down along its entire length.
- The positioner must be mounted to a flat, stable surface, with a flatness error less than or equal to 0.013mm/300mm.
 - Catalog specifications may deviate for positioners mounted to surfaces that do not meet the above conditions.
 - If the surface does not meet these specifications the surface can be shimmed to comply with these requirements.
- If mounting conditions require that the table base is *overhung*, table specifications will not be met over that portion of the table. Additionally, in *X-Y Systems* the *overhung* portion of the Y-axis may not meet specifications due to the additional error caused by deflection and non-support of the base. Contact Parker for guidelines on specifications of overhang applications.

Mounting Methods

The 404LXR can be mounted via the two (2) following methods:

1) Toe Clamps

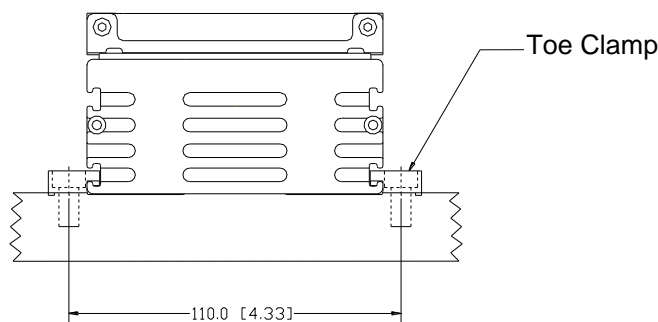

Toe Clamp Mounting
P/N 100-8376-01
Counterbores for M6

2) Taped Holes on the underside of the 404LXR

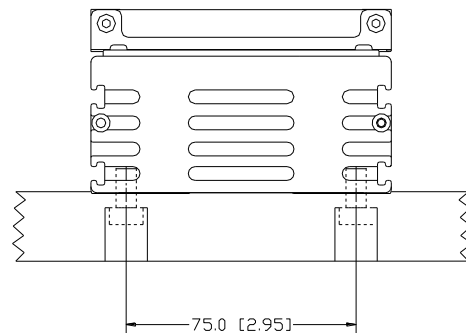

Bottom Tapped Holes
M5 X 0.8 X 7.5 Long
Note: Maximum Allowable
Bolt Length is 7.0 mm

Side and Inverted Mounting Concerns

Side Mounting

- Cable transport modules are NOT to be used on side mounted positioners with travels greater than 600 mm due to cable drag.

Inverted Mounting

- Cable transport modules are NOT to be used on inverted mounted positioners with travels greater than 450 mm due to cable drag. Contact factory for special bracketry.

Setting Travel Limit Sensors

The LXR is supplied with over-travel limit sensors. Set the position of the sensors before applying power. The limit sensors are set at the factory for maximum travel. These factory settings only allow for 3mm (0.12") before the carriage contacts the deceleration bumper. In slow speed applications this may be adequate, however as the top speed of the application increases the required deceleration distance increases. To determine the safe **Deceleration Distance** the **Maximum Speed** and the **Maximum Obtainable Deceleration Rate** must be *known or calculated*. The maximum speed should be known from your application requirements. *Velocity limits* should be set in your program or in your amplifier to cause a fault if the speed exceeds this value. The maximum deceleration is a factor of load and available peak force of the table. Using $F = ma$, calculate maximum acceleration and then required deceleration distance. See the following example for calculating *maximum deceleration* for an application with a payload = 5kg on a 404LXR-D13 (8 pole motor), with a maximum speed of 1.5 m/s.

Payload mass = 5 kg, Carriage mass = 1.5 kg
Total mass = 6.5 kg

Maximum Speed = 1.5 m/sec

Available peak force at 1.5 m/sec = 155N (See Chapter 2, *Force / Speed Curve*)

Thus: $F = ma \rightarrow a = F/m \rightarrow a = 155N / 6.5kg \rightarrow 23.8 \text{ m/sec}^2$ or $2.4g$'s

The **Maximum Obtainable Deceleration Rate** for this application is **23.8 m/sec²**.

Now, calculate the **Deceleration Distance** for linear deceleration:

First... find the Deceleration time:

$$T_a = \text{Max Velocity} / \text{Deceleration Rate}$$

$$T_a = 1.5\text{m/sec} / 23.8 \text{ m/sec}^2 \rightarrow 0.063 \text{ seconds}$$

Second... find the Deceleration Distance:

$$\text{Distance} = ((\text{Max Velocity}) * (T_a)) / 2$$

$$\text{Distance} = ((1.5 \text{ m/sec}) * (0.063)) / 2 \rightarrow 0.047 \text{ meters or } \underline{47 \text{ mm}}$$

This means that both the positive and negative limit switch targets must be moved inward by 47mm. The limit deceleration rate should be set to 24.22 meters/sec².

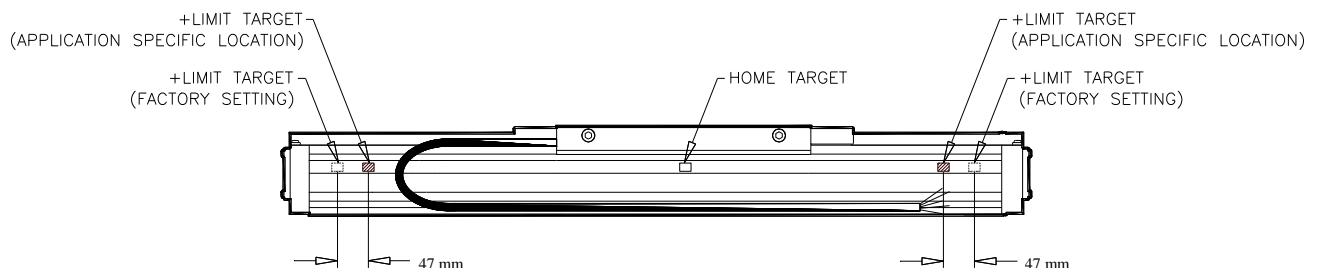

Setting Home Sensor

The 404LXR is equipped with a “home” position reference sensor. This is located on the same bracket as the limit sensors and the target is located between the limit targets. This sensor is typically used in conjunction with the encoder “Z” marker (refer to “Z” channel reference below). If the unit is equipped with this option it will be set at the “Z” channel location. If another home location is desired the home target can be adjusted by loosening the screws on the target and sliding it along the track. Note: If the home sensor is used without “Z” channel, repeatability is reduced to +/-5 microns.

Z Channel Position Reference

The Z channel is an output on the encoder. Many servo controllers support this input. The Z channel on the 404LXR is located in one of three positions, (positive end, mid travel, or negative end). The location depends on how the unit was ordered (See Chapter 2, *Order Number Nomenclature*). The Z channel is a unidirectional device. This means that the final homing direction must occur in one direction. The 404LXR is set that the final home direction is to be toward the positive side of the table (See Chapter 2, *Dimensional Drawing*, for positive direction definition). The repeatability of the Z channel is equal to +/- 2 resolution counts of the encoder (except for 0.1 micron scales which have a repeatability of +/-1 microns). Thus the repeatability of the “Z” channel equals:

Encoder Resolution	Z Channel Repeatability
5 micron	+/- 10 micron
1 micron	+/- 2 micron
0.5 micron	+/- 1 micron
0.1 micron	+/- 1 micron

NOTE: Home repeatability is also very dependent on controller input speed and homing algorithms. The above repeatability does not include possible controller tolerance. Additionally, to achieve the highest repeatability the final homing speed must be slow. Slower final speed usually results in higher repeatability.

NOTE: The “Z” channel output is only one resolution count wide. Thus the on-time may be very brief. Due to this some controllers may have difficulty reading the signal. If you are experiencing the positioner not finding the “Z” channel during homing, try reducing final homing speed; also refer to your controller manual for frequency rates of the “Z” channel input.

Grounding / Shielding

All cables are shielded. These shields are to be grounded to a good earth ground. Failure to ground shields properly may cause electrical noise problems. These noise problems may result in positioning errors and possible run away conditions.

Cabling

The 404LXR is available with two (2) types of cabling:

- Cable Transport Module
 - This is a complete cable management system including high flex cable (life rating of 10 million cycles, dependent on motion cycle speeds, acceleration and environmental condition), cable carriers, and connector system. This has been engineered for high life, maintenance free operation. Extension cables are used to connect the table connector block to the amplifier and controller. Refer to cabling diagrams for pin-out and wire color information.
 - The Cable transport module is replaceable. See Chapter 6, *Cable Management Module Replacement*, for replacement P/N's and a detailed procedure of the replacement process.

- Un-harnessed OEM Cable System
 - This option provides high flex round cables directly from the carriage. This option is provided for applications where the design of the machine already has a cable management system. Four cables come from the carriage connector: motor, encoder, Hall effect and limit/home sensor cables.
 - Recommended bend radius for these cables is 100mm. This radius will provide 10 million cycles of the cable. Smaller bend radius will reduce cable life while larger bend radius will increase life. The un-harnessed OEM cable system can be replaced. Refer to Chapter 6, *Cable Management Module Replacement*. The same carriage connector is used here and can be removed and replaced with a new assembly.

Chapter 4 - Performance

Acceleration Limits

Acceleration of the 404LXR is limited by four (4) factors:

- Linear Bearings

The Linear bearings used in the 404LXR have a continuous acceleration limit of 2 g's. This means that the bearings are design to take repetitive acceleration of 2 g's and maintain the rated bearing life. Additionally, the bearings can take a periodic acceleration of up to 5 g's, however continued accelerations of these magnitudes will reduce bearing life.

- Reduced Bearing Life

Bearing loading due to high acceleration may reduce bearing life to an unacceptable application limit. This is not usually a limiting factor unless loading is significantly cantilevered causing high moment loads during accelerations. (Chapter 2, *404LXR Series Technical Data* to determine bearing load life for your application)

- Available Motor Force

This is the primary factor that reduces acceleration. This is simply the amount of motor force available to produce acceleration. The larger the inertial and or frictional load the lower the accelerations limit.

- Settling Time

In many applications reducing cycle time is a primary concern. To this end, the “settling” time (the amount of time needed after a move is completed for table and load oscillating to come within acceptable limits) become very important. In many cases where very small incrementing moves are executed, the settling time is greater than the actual move time. In these cases accelerations may need to be reduced thus reducing the settling time.

Speed Limits

The Maximum Speed of the 404LXR is limited by three (3) factors:

- Linear Bearings

The linear bearings are limited to a maximum speed of 3 meters/second.

- Linear Encoder Limit

The linear encoder has speed limits relative to encoder resolution; these limits are listed below:

Encoder Resolution	Maximum Velocity	Required Post Quadrature Input Bandwidth ⁽²⁾
5 micron	5 meters/second ⁽¹⁾	2 Mhz
1 micron	3 meters/second	6.7 Mhz
0.5 micron	1.5 meters/second	6.7 Mhz
0.1 micron	0.3 meters/second	10 Mhz

⁽¹⁾ When using an encoder with 5 micron resolution, the maximum speed is limited by the square rail bearings.

⁽²⁾ This is the bandwidth frequency that the amplifier or servo control input should have to operate properly with the encoder output at maximum speeds. This frequency is post-quadrature, to determine pre-quadrature divide above values by 4. Above frequencies include a safety factor for encoder tolerances and line losses.

- Force / Speed Limit

The available force of the 404LXR reduces as speed increases. (Chapter 2, *404LXR Series Technical Data*)

Encoder Accuracy and Slope Correction

Encoder Accuracy

The 404LXR Series makes use of an optical linear tape encoder for positional feedback. This device consists of a *readhead*, which is connected to the carriage, and a *steel tape scale*, which is mounted inside the base of the 404LXR.

The linearity of this scale is +/-3 microns per meter, however the absolute accuracy can be many times larger. To compensate for this error, an error plot of each 404LXR is done at the factory using a laser interferometer. From this plot a linear slope correction factor is calculated (see below). Then a second error plot is run using the slope correction factor. These tests are conducted with the Point of Measurement (P.O.M.) in the center of the carriage 38 mm above the carriage surface.

Slope Correction

Slope correction is simply removing the linear error of the table. The graphs below show an example of a non-slope corrected error plot and the same plot with slope correction. As can be seen, the absolute accuracy has been greatly improved.

The slope factor is marked on each unit. It is the slope of the line in microns per meter. This factor may be positive or negative, depending on the direction of the error.

If your application requires absolute accuracy, the slope factor must be incorporated into the motion program. This is a matter of either assigning variables for motion positions and using the slope correction in the variable equation, or if your controller has floating decimal scaling (with high enough precision) the slope correction can be accounted for in scaling.

NOTE: The zero position (or starting point) of the error plots are at the extreme NEGATIVE end of travel (refer to Chapter 2, *Dimensional Drawing*, for Negative end location).

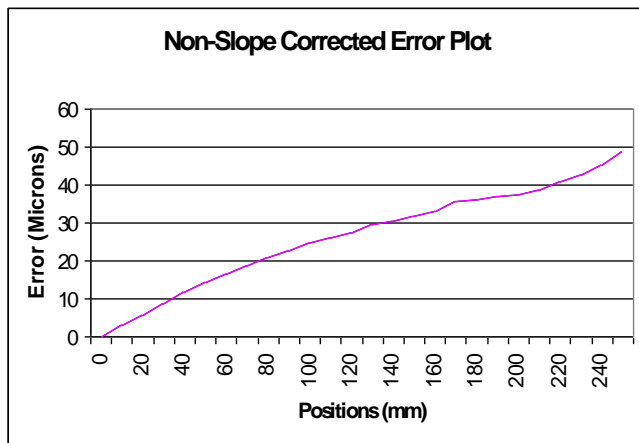

Non-Slope Corrected Error Plot, Total error 48 microns
Note: Slope Factor is 200 micron / meter in this

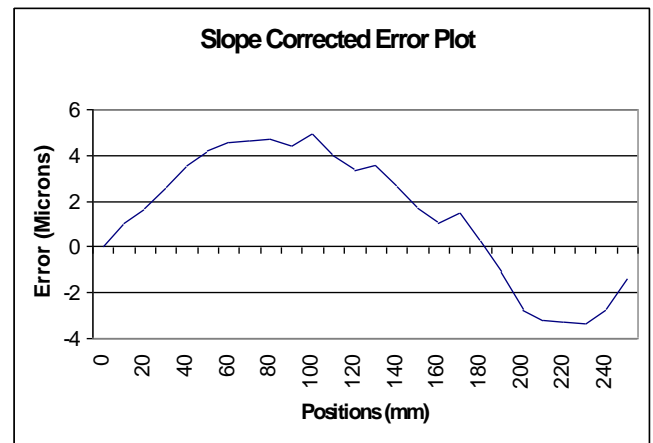

Slope Corrected Error Plot, Total error 8.5 microns

Below is a sample program showing how to correct for slope error using variables. This example program will work with the 6K as well as the 6000 Series Parker Controllers. Step 2 through 3 of this program should be made a subroutine. This subroutine can then be executed for each distance.

```

.....
• Step #1
VAR1 = 880; IN THIS CASE THE DESIRED DISTANCE IS 880mm.

• Step #2
DEL SLCORR ; DELETE SLCORR PROGRAM
DEF SLCORR ; DEFINE SLCORR PROGRAM
VAR2 = (VAR1/1000)* (0.085); VAR2 EQUALS DESIRED DISTANCE (IN METERS) TIMES THE
SLOPE FACTOR (mm/meter)

• Step #3
VAR3 = (VAR1-VAR2); SUBTRACT SLOPE ERROR FROM DESIRED DISTANCE

• Step #4
D(VAR3); SET DISTANCE AS VAR3
END ; END SUBROUTINE
.....

```

In the example above, the required move distance is 880 mm. But the LXR has a slope error of 0.085mm per meter. This is a positive slope error meaning that if uncorrected the LXR will move 0.085 mm too far for every meter it travels. To correct we must command a smaller position.

- Step #1: The required move distance is set as variable #1.
- Step #2: In this step, we first convert 880 mm to 0.88 meters by dividing by 1000. Next we multiply by the slope factor to calculate the slope error distance of this move $(0.88 * 0.085) = 0.0748$ mm.

- Step #3: We subtract the error from the original distance ($880 - 0.0748$) = 879.9252 mm.
- Step #4: Here we simply assign the new calculated distance as our current command distance.

This same program works if the slope error is negative. For example, if the slope error was -0.085 instead of $+0.085$ the equation would work out like this:

$$\text{VAR2} = (880/1000)*(-0.085) = -0.0748$$

$$\text{VAR3} = 880 - (-0.0748) = 880.0748$$

Thus correcting for the negative slope.

Note: Above are examples for incremental moves. The same program works if programming in absolute coordinates.

Note: Each unit is shipped with both the non-slope corrected accuracy plot and a slope corrected plot. These plots can be used to “MAP” the table, making positioning even more accurate. Mapping is correcting for the error of the device at each location. This can be done by knowing the motion positions and the error at each of these positions and setting up a matrix of variables in your motion program. This method provides excellent accuracy but is time consuming to setup.

Attainable Accuracy with Slope Correction			
Travel (mm)	Accuracy (microns)	Travel (mm)	Accuracy (microns)
50	6	400	18
100	7	500	21
150	8	600	25
200	10	700	28
250	12	800	31
300	14	900	33
350	16	1000	35

Thermal Effects on Accuracy

All specifications for the 404LXR are taken at 20° C. Variation from this temperature will cause additional positional errors. If the base of the 404LXR varies from this temperature the encoder scale will expand or contract, thus changing its measuring length and thus encoder resolution.

The factor by which this thermal effect occurs is 0.000022mm/mm/° C. Although this sounds like a very small number it can make significant accuracy and repeatability effects on your applications, especially on longer travel applications. To understand this better let's look at an example:

Example: A 404LXR with 900mm travel is being used. The accuracy over the entire travel is 40 microns @ 20° C. If the base temperature increases by 5° C an additional error of 99 microns will be added over the total travel ($0.000022\text{mm/mm/}^\circ\text{C} \times 900\text{mm} \times 5^\circ\text{C}$). As you can see this error is significant. However, this additional error can be compensated for since the error is linear.

On the next page is a graph of the accuracy of the 404LXR with respect to base temperature and travel. Each line represents the additional error of the table caused by the elevated temperature.

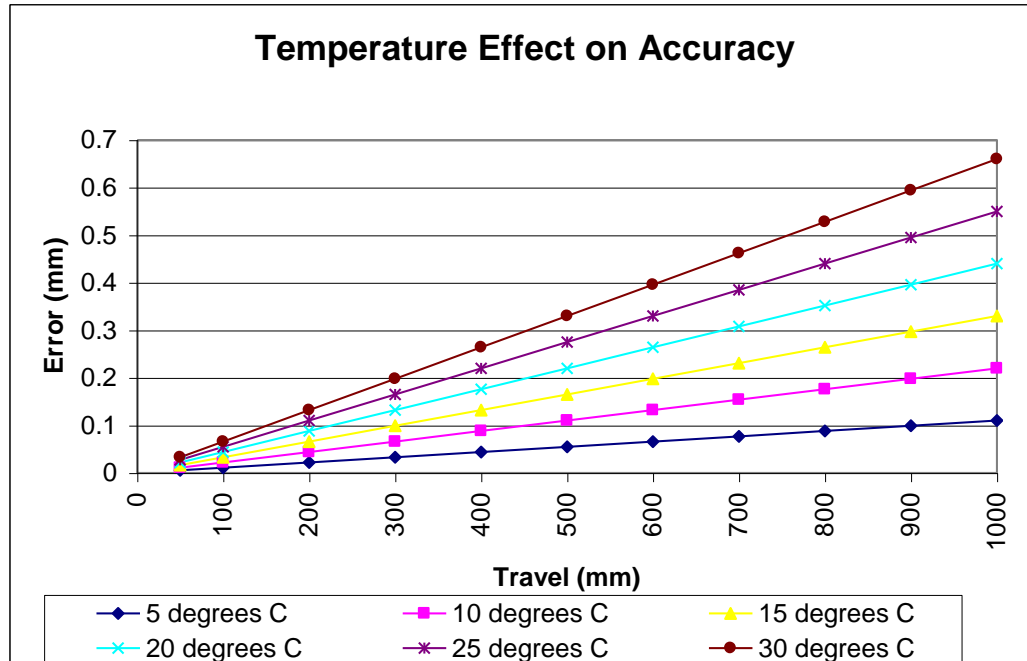

Thermal Effects on Repeatability

Repeatability will not be effected as long as the temperature remains constant. However the repeatability will be effected as the temperature changes from one level to another. This is most commonly experienced when starting an application cold. Then as the application runs the 404LXR comes to its operational temperature. The positions defined when the unit was “cold” will now be offset by the thermal expansion of the unit. To compensate for this offset, all positions should be defined after the system has been exercised and brought to operational temperature.

Causes of Temperature Increases

One or more of the following conditions may effect the temperature of the 404LXR base:

- Ambient Temperature

This is the air temperature that surrounds the 404LXR.

- Application or Environment Sources

These are mounting surfaces or other items which produce a thermal change that effect the temperature of the 404LXR base (i.e. Machine base with motors or other heat generating devices that heat the mounting surface and thus thermally effect the 404LXR base).

- Motor heating from 404LXR

Since the 404LXR uses a servo motor as its drive, it produces no heat unless there is motion, or a force being generated. In low duty cycle applications heat generation is low, however as duty cycles increase, temperature of the 404LXR will increase, causing thermal expansion of the base. With very high duty cycles these temperatures can reach temperatures as high as 30° C above ambient.

Compensating for Thermal Effects

How much you will have to compensate for the above thermal effects depend on the application requirements for accuracy. If your accuracy requirements are high, you either need to control base temperature or program a thermal compensation factor into your motion program. *Controlling the base temperature* is the best method. However, this means controlling the ambient temperature by removing all heat/cold generators from the area and operating at very low duty cycles. *Compensation* is the other way of achieving accuracy without sacrificing performance. In this case the system must be exercised through its normal operating cycle. The temperature of the base should be measured and recorded from the beginning (cold) until the base becomes thermally stable. This base temperature should be used in a compensation equation. Below is the fundamental *thermal compensation equation*:

$$Cd = (ld - (ld) * (Te) * \Delta T)$$

Cd = Corrected displacement (mm)

ld = Incremental displacement (mm)

Te = Thermal Expansion (0.000022 mm/mm/° C)

ΔT = Temperature Differential from 20° C

Example:

- Base Temperature of 32° C
- Required move 100mm

$$Cd = 100mm - (100mm * Te * 12° C) = 99.9736mm$$

In this move the commanded move should be 26.4 microns less (100mm – 99.9736mm) than the desired move. This will compensate for the thermal expansion of the scale.

This is a simple linear correction factor and can be programmed in to most servo controllers using variables for the position commands.

Chapter 5 - Connecting the Drive / Amplifier

Drive / Amplifier connection

The images below give an overview of how to connect a 404LXR to a Gemini, Aries or Compax3 digital servo drive. Gemini examples are shown for the A4 drive only and the A5 drive/controller options.

With an Aries or Gemini GV Drive and a 6K controller

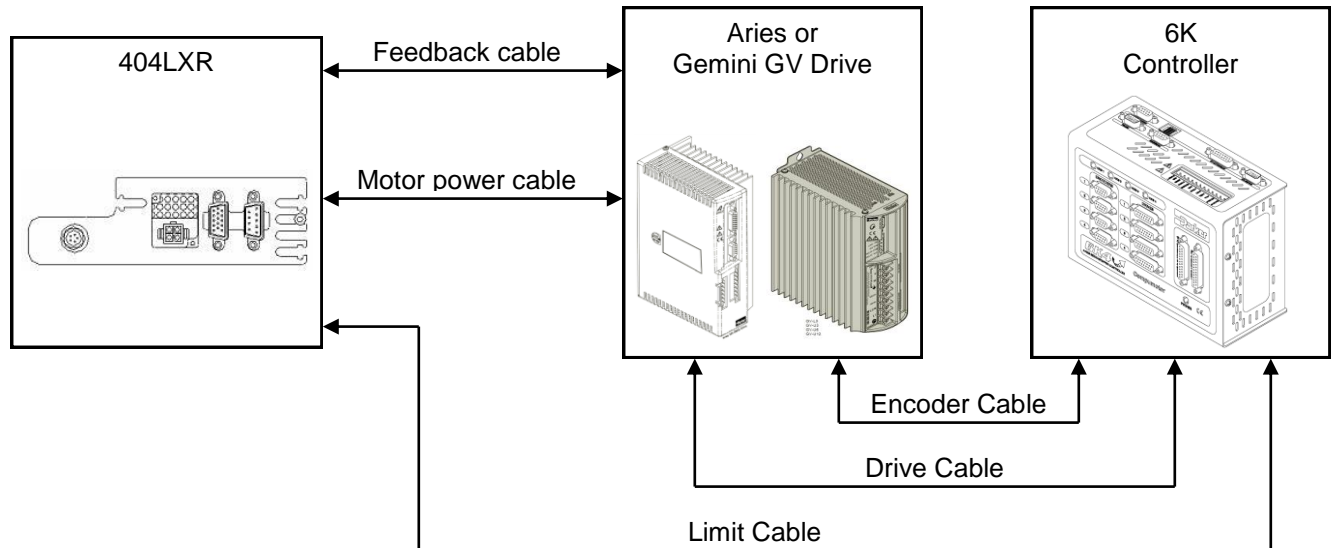

With a Gemini GV6 Drive/Controller

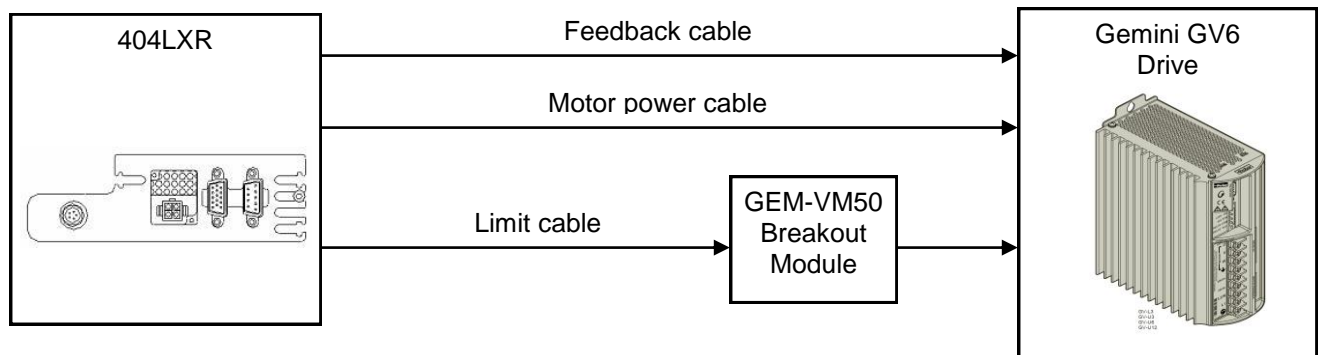

With a Compax3 Drive/Controller

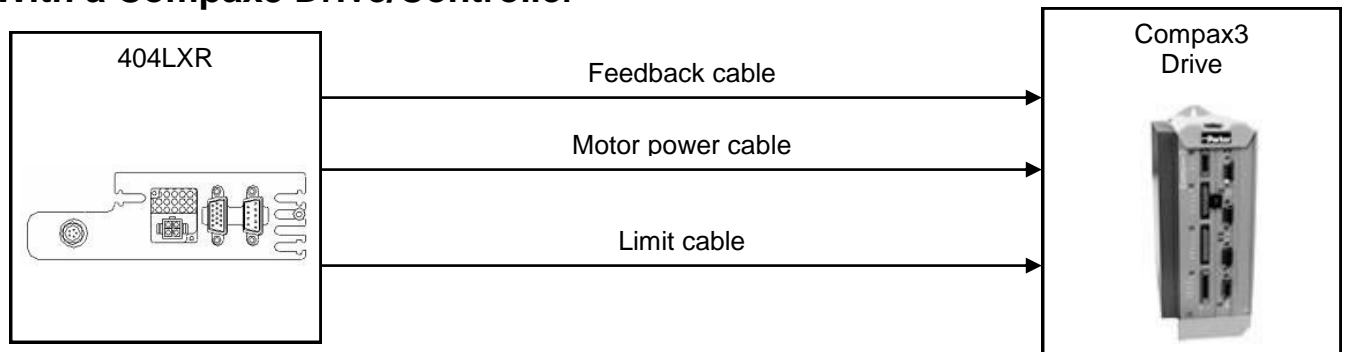

Gemini Adapter Cable

- Use this cable to connect the Encoder and Hall Effect signals from an electrical panel strip to the Gemini's 26 pin Motor Feedback connector.

Function	Wire Color	Pin #
Encoder Wires		
Ch A+	White	5
Ch A-	Yellow	6
Ch B+	Green	7
Ch B-	Blue	8
Ch Z+	Orange	9
Ch Z-	Brown	10
Ground	Black	3,4
+5 VDC	Red	1,2
Hall Signal Wires		
Hall Gnd	White/Green	15
Hall +5V	White/Blue	14
Hall 1	White/Brown	16
Hall 2	White/Orange	17
Hall 3	White/Violet	18
Temperature Switch		
Temp Switch	Yellow/Orange	12
Temp Switch	Yellow/Red	13
Shield	Yellow/Green	Shield Cover

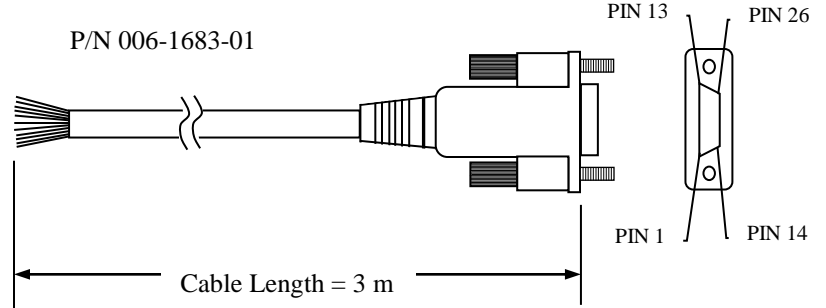

Gemini Plug-in Connection Module

- Use this module to directly connect the 404LXR's Encoder and Hall Effect cables to the Gemini Drive.

Function	Wire Color	Pin #
Encoder Wires		
Ch A+	White	5
Ch A-	Yellow	6
Ch B+	Green	7
Ch B-	Blue	8
Ch Z+	Orange	9
Ch Z-	Brown	10
Ground	Black	3,4
+5 VDC	Red	1,2
Shield	Green/Yellow	Shield Cover
Hall Signal Wires		
Hall Gnd	White/Green	15
Hall +5V	White/Blue	14
Hall 1	White/Brown	16
Hall 2	White/Orange	17
Hall 3	White/Violet	18
Shield	Green/Yellow	Shield Cover
Temperature Switch		
Temp Switch	Yellow	12
Temp Switch	Yellow	13

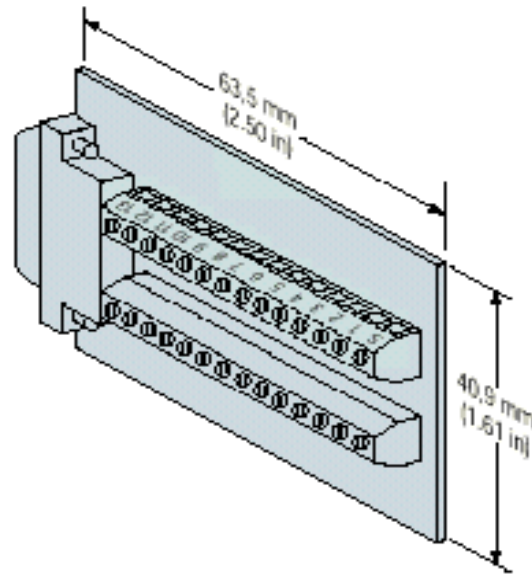

Gemini Motor Phase Connections

- Use these Connections to connect the LXR's Fork Terminal Motor Phase Cable to the Gemini Drive.

Function	Wire Color	Pin #
Motor Phase		
Phase A	Black #1	U
Phase B	Black #2	V
Phase C	Black #3	W
Ground	Green/Yellow	Grd
Shield	Shield	Shield Cover

Note: For Maximum Noise Immunity It is recommended that the end of the Motor Cable be strip back and connected to the Ground clamp located on the side of the Gemini. See Gemini Hardware manual for grounding details.

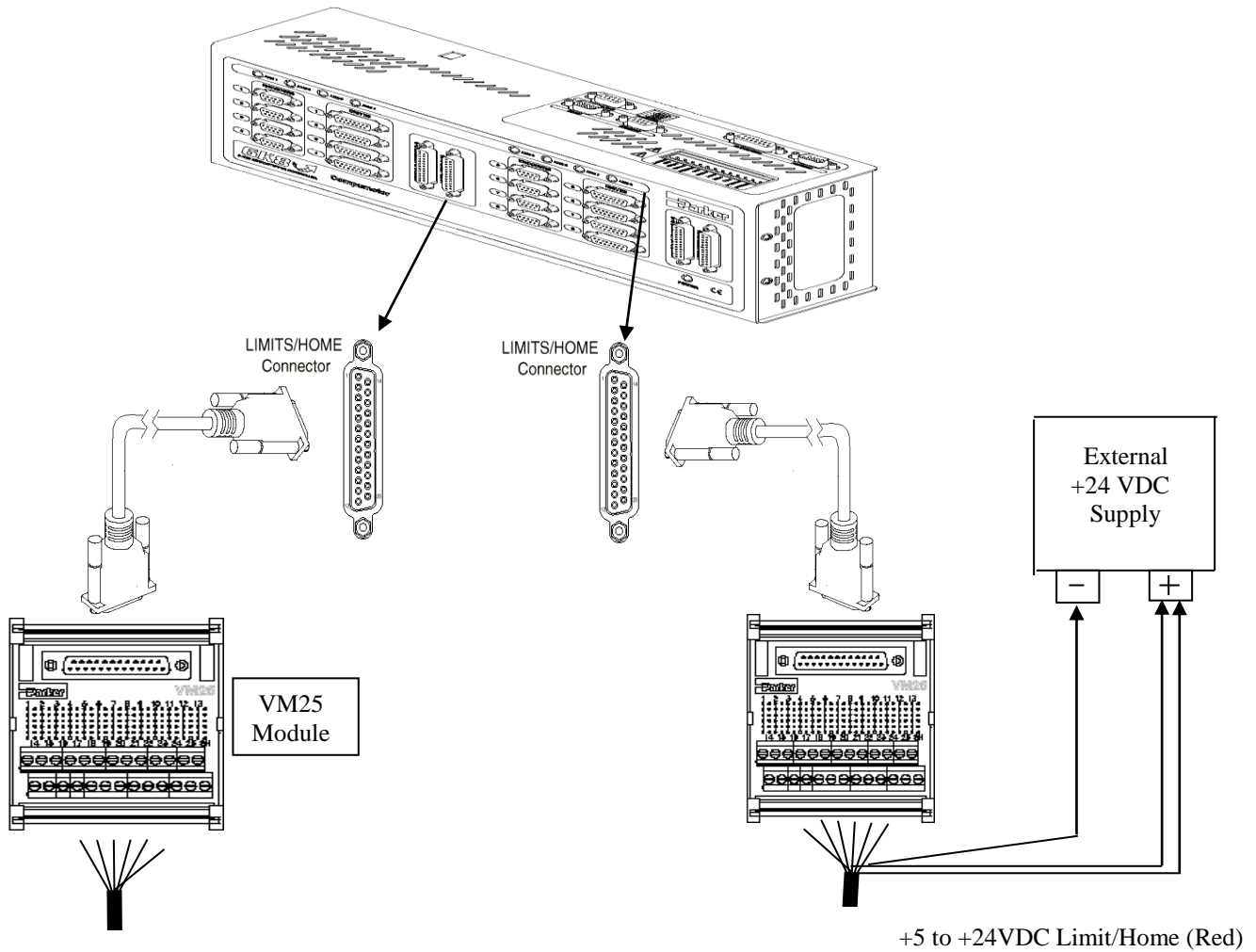

LXR Limit/Home Cable
P/N 006-1742-0X

VM25 Pin Outs**								Function	Wire Color*	LXR Pin #
1	2	3	4	5	6	7	8			
Connect to external power supply (see above)								+5 to +24VDC	Red	A
21	15	9	3	21	15	9	3	(-) Limit	Blue	B
23	17	11	5	23	17	11	5	(+) Limit	Orange	C
19	13	7	1	19	13	7	1	Home	Green	D
All even pins are connected to logic ground.								Ground	Black	E

* Color scheme of the flying leads from the Limit/Home Cable. P/N 006-1742-0X.

** Axes 1-4 use the first 25-pin limits/home connector and axes 5-8 use the second limits/home connector on the 6K.

Chapter 6 - Maintenance and Lubrication

Internal Access Procedure

The following procedure outlines the steps required to access the interior of the positioner.

- Remove carriage end caps by removing four (4) M3 Socket Head Cap Screws (2pc/carriage side) using a 2.5 mm Allen wrench.
- Pull carriage end caps off. Carriage end caps on both sides of carriage must be removed.
- Remove the two (2) strip seals clamps by removing four (4) Phillips Head Screws.
- Remove strip seal cover plate.

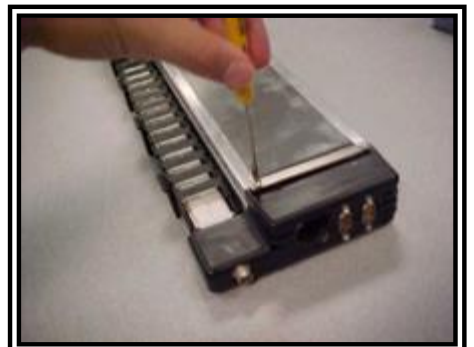
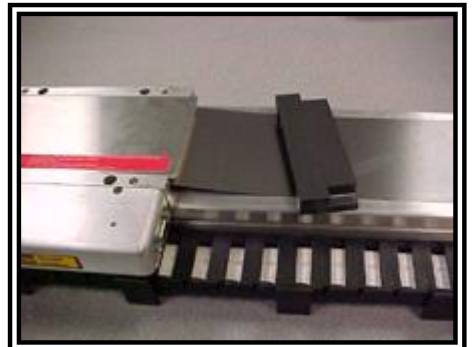

- Carefully pull the strip seal through the carriage.
- Caution: The strip seal ends are VERY SHARP.



- Remove both wear bars that are located on the carriage.

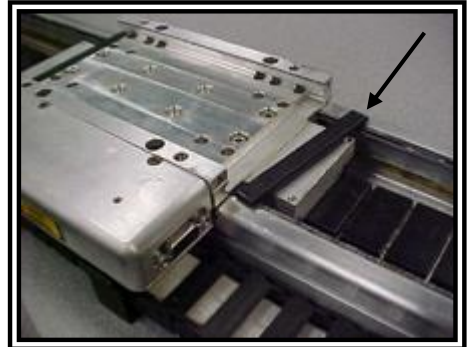
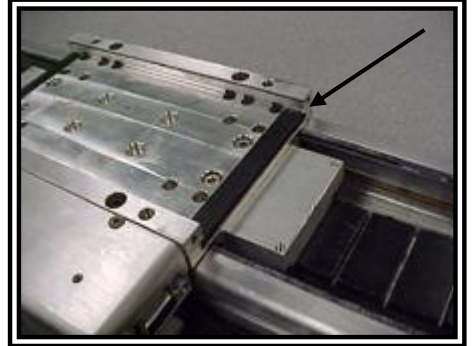

Reassemble positioner by reversing steps.

Square Rail Bearing Lubrication

See Section on *Internal Access* for procedure to access interior of positioner.

Materials Required: Multemp PS2, Isopropyl Alcohol, Clean Cloth, Small Brush

- Lubrication Type:

Multemp PS2, part number 003-3686-19. Lithium, Diester oil based, drop point 189°C, Penetration at 25°C = 250-275, temperature range -55~100°C, Low temperature grease.

- Lubricant Appearance:

White, light cream

- Maintenance Frequency:

Square rail bearing blocks are lubricated at our facility prior to shipment. For lubrication inspection and supply intervals following shipment, apply grease every 1000 hours of usage. The time period may change depending on frequency of use and environment. Inspect for contamination, chips, etc, and replenish according to inspection results.

- Lubricant Application:

Wipe the rails down the entire length with a clean cloth. Apply lubrication on the rails allowing a film of fresh grease to pass under the wipers and into the recirculating bearings. After bearings are relubricated clean encoder tape scale located on inside wall of table. Clean with lint free cloth, removing all dirt and grease. Using a lint free cloth, wipe down linear tape scale with isopropyl alcohol.

- Note:** Do not use/mix petroleum base grease with synthetic base grease at any time. For lubrication under special conditions consult factory.

Cable Management Module Replacement

- Order replacement Cable Management Module Below:

Travel Code	Replacement Part #	Travel Code	Replacement Part #	Travel Code	Replacement Part #
T00	006-2414-01	T08	006-2414-05	T15	006-2414-18
T01	006-2414-11	T09	006-2414-15	T16	006-2414-09
T02	006-2414-02	T10	006-2414-06	T17	006-2414-19
T03	006-2414-12	T11	006-2414-16	T18	006-2414-10
T04	006-2414-03	T12	006-2414-07	T19	006-2414-20
T05	006-2414-13	T13	006-2414-17	T20	006-2414-21
T06	006-2414-04	T14	006-2414-08	T21	006-2414-22
T07	006-2414-14				

While the instructions in the following procedure show cable options that are no longer available, the procedure itself is still accurate.

- Remove two (2) M3 Flat Head Screws from the top of the cable carrier by using a 2.5 mm Allen wrench.
- Pull the carriage connector off, taking care to pull straight off to avoid bending the connectors.
- Remove the strip seal clamp on the connector end by removing two (2) Phillips Head Screws.
- Remove two (2) M3 Button Head Screws from connector end by using a 2.5 mm Allen wrench.

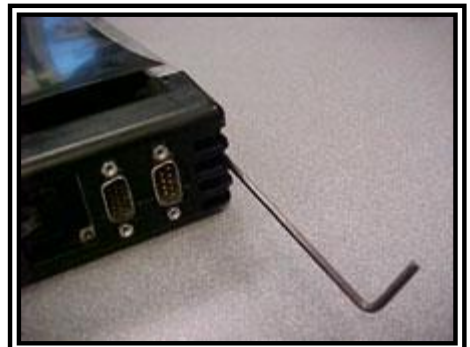
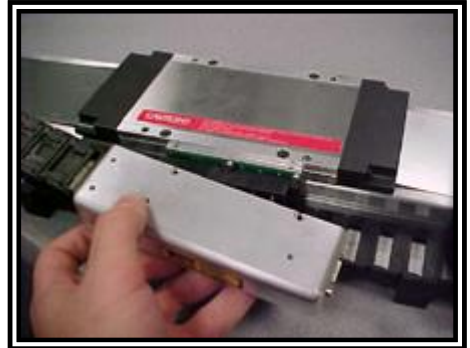
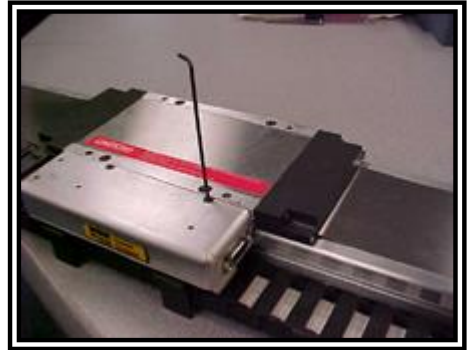

Replacement modules are mounted by reversing steps.

Limit and Home Sensor Module Replacement

- Remove two (2) M3 Flat Head Screws from the top of the cable carrier by using a 2.5 mm Allen wrench.
- Pull the carriage connector off, taking care to pull straight off to avoid bending the connectors.
- Locate the limit/home wire connection and disengage the connector.
- Remove the two (2) T6 Torx® flat head screws that attach the limit/home switch to the cable carrier.

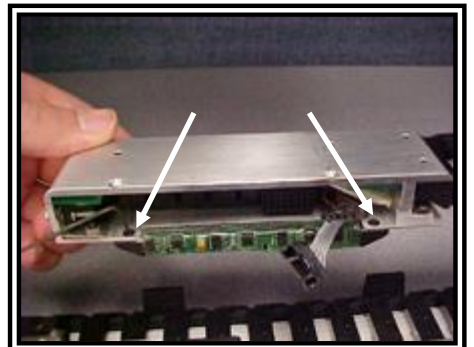
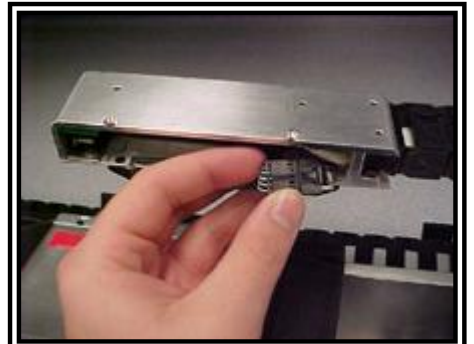
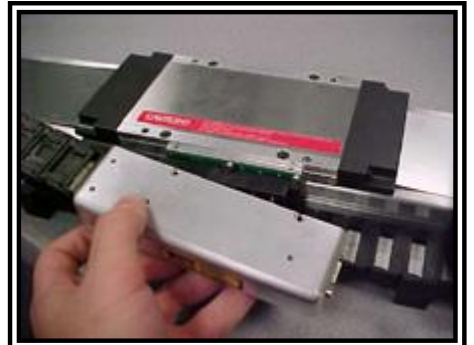
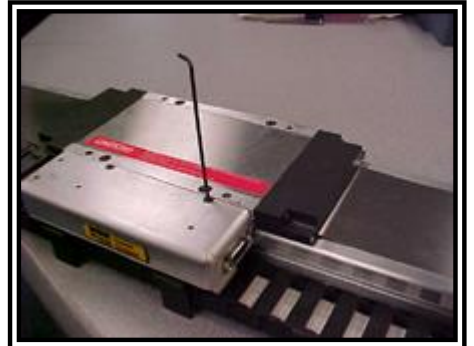

Replacement switches are mounted by reversing steps.

Appendix A – Understanding Linear Motors

The Linear Motor Concept

Linear Motors are basically a conventional rotary servo motor unwrapped. So now what was the stator is now called a forcer and the rotor becomes a magnet rail. With this design, the load is connected directly to the motor. No more need for a rotary to linear transmission device.

Linear Motor Benefits

- **High speeds:** Only the bus voltage and the speed of the control electronics limit the maximum speed of a linear motor. Typical speeds for linear motors are 3 meters per second with 1 micron resolution and over 5 meters per second with coarser resolution.
Note: Motors must be sized for specific loading conditions.
- **High Precision:** The feedback device controls the accuracy, resolution, and repeatability of a linear motor driven device. And with the wide range of linear feedback devices available today, resolution and accuracy are primarily limited to budget and control system bandwidth.
- **Fast Response:** The response rate of a linear motor driven device can be over 100 times faster than some mechanical transmissions. This is simply because there is no mechanical linkage. This means faster accelerations and settling times, thus more throughput.
- **Stiffness:** Because there is no mechanical linkage in a linear motor, increasing the stiffness is simply a matter of gain and current. Thus the spring rate of a linear motor driven system can be many times that of a ball screw driven device. However it must be noted that this is limited by the motor's peak force, the current available, and the resolution of the feedback.
- **Zero Backlash:** Since there are no mechanical components there is no backlash. There are however, resolution considerations which effect the repeatability of the positioner (See Chapter 2, *General Table Specifications*, Chapter 3, *Setting Home Sensor and Z Channel Position Reference*)
- **Maintenance Free Drive Train:** Because linear motors of today have no contacting parts, in contrast with screw and belt driven positioners, there is no wear on the drive mechanism.

Slotless Linear Motor Design

The Linear Motor inside the 404LXR is a Slotless Linear Motor. The following will give a brief description of the motor design and construction:

- **Construction:** Designed by Divisions of Parker Hannifin, the motor takes its operating principle from Parker's slotless rotary motors which have grown popular over the past few years. The magnetic rail is simply a flat iron plate with magnets bonded to it. The forcer is unique. It begins with a coil and a "backiron" plate, which is placed behind the coil. This assembly is placed inside an aluminum housing with an open bottom. The housing is then filled with epoxy, securing the winding and "backiron" into the housing. The thermal sensors and hall effect sensors are mounted to the housing.

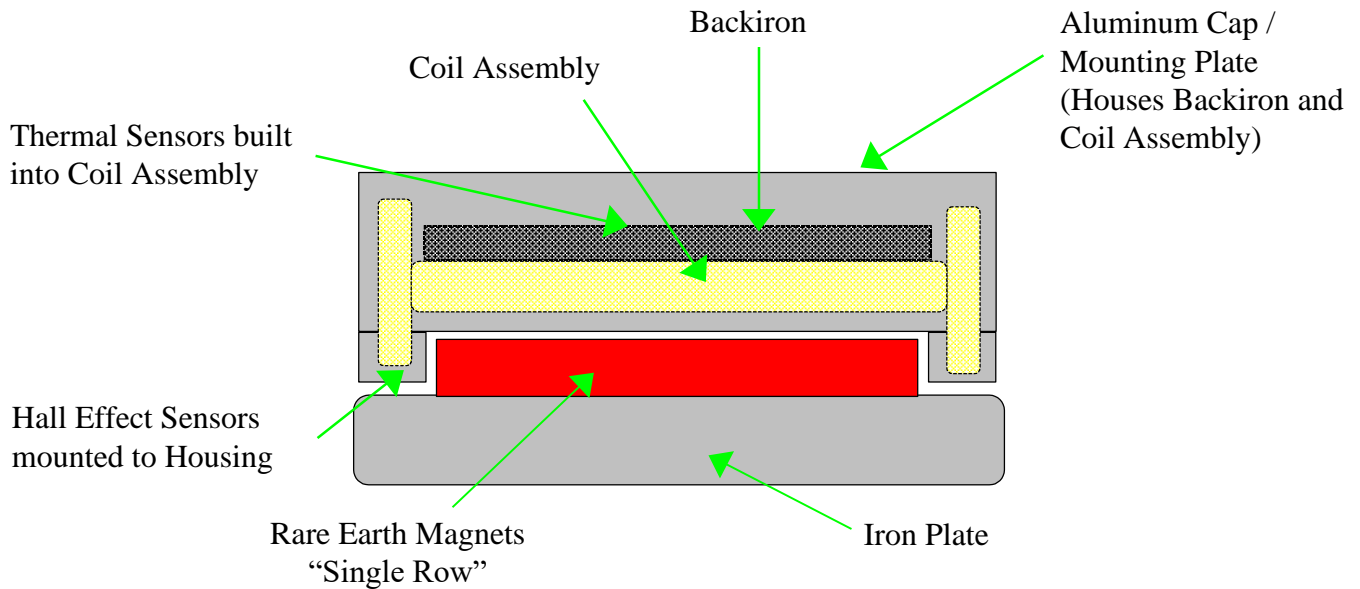

Advantages/Disadvantages of Slotless Linear Motors

- **Lower Weight Magnetic Rail:** Since this is a single magnet rail the weight is less than half of dual magnet rail motors. This means less load and higher throughput in multi-axis systems.
- **Structurally Strong Forcer:** With the body of the forcer being made of aluminum and the windings being bonded to this housing, the strength of the forcer is much greater than that of the epoxy only housed motors. Thus reducing the possibility of motor fatigue failures.
- **Light Weight Forcer:** Because of its aluminum body construction, the slotless linear motor forcer weight is approximately 2/3 that of an equivalent iron core linear motor. Thus resulting in higher throughput in light load applications.
- **Lower Attractive Forces:** The slotless design has a "backiron" causing attractive forces between the forcer and the rail. However, this attractive force is significantly less than other linear motors. Thus significantly reducing loading on the linear guide bearings and increasing bearing life.
- **Lower Cogging:** Due to the larger magnetic gap between the magnets and forcer "backiron" the slotless design has lower cogging. This enables the slotless design to operate in applications that require very good velocity control.
- **Heat Dissipation:** The slotless design, with the coil resting across the "backiron", which is in direct contact with the aluminum housing, has very good heat transfer characteristics and is easy to manage.

Appendix B - Internal Protection

The 404LXR is protected from its environment via a magnetically retained protective seal. Parker has conducted testing to determine the *degree* to which the positioner is protected by using a British standard called an **Ingress Protection Rating (IP Rating)**.

Definition

Reference: British standard EN 60529 : 1992

This standard describes a system of classifying degrees of protection provided by enclosures of electrical equipment. Standardized test methods and the establishment of a two digit numeric rating verify the extent of protection provided against access to hazardous parts, against ingress of solid foreign objects, and against the ingress of water.

First Number – The first number indicates protection of persons against access to dangerous parts and protection of internal equipment against the ingress of solid foreign objects.

- 1 - Protection against access to hazardous parts with the back of a hand, and protected against solid foreign objects of 50 mm diameter and larger.
- 2 - Protection of fingers against access to dangerous parts, and protection of equipment against solid foreign objects of 12.5 mm diameter and larger.
- 3 - Protection against access to hazardous parts with a tool, and protection against solid foreign objects of 2.5 mm diameter and larger.

Second Number – The second number indicates protection of internal equipment against harmful ingress of water.

- 0 - No special protection provided.

Note: Number Indicators above represent only a partial list of IP Rating specifications.

Warnings (Points of Clarity)

- The specification applies to protection of particles, tools, parts of the body, etc., against access to hazardous parts inside the enclosure. This does not cover external features such as switch pinch points, pinch points caused by the motion of the carriage, or cable carrier assemblies.
- The testing method as specified in the standard uses a solid steel rod of the appropriate diameter at a specified force. The specification does not consider soft or pliable particles. Due to the design of the table and sealing method, a soft particle can compress due to the motion of the table, and reduce its cross-section. This can allow particles to enter the unit.
- In application, shavings or chips commonly created in a machining operation are a greater concern. If any edge or dimension of the “chip” is under the appropriate diameter, it can wedge under and start to lift the seals. This action will allow larger particles to do the same until failure is reached.

Product Rating

All standard configurations will pass IP20 specifications with the following exception:

- The cable carrier is not covered by the specification.

All standard configurations, (less cable carrier), can be configured to pass IP30 specifications by utilizing the “IP ship kit” supplied with each unit as follows:

- Using the supplied *aluminum foil disks*, cover all *counter-bored base mounting holes* that are not covered by your mounting surface. The disks should be installed from the outside of the unit. Depending on the travel length, some disks will not be used.
- Using the supplied *aluminum foil disks*, plug all unused *carriage mounting holes* that are not covered by the load or load plate.
- Using the supplied *aluminum foil disks*, plug all *threaded base mounting holes* that are not covered by your mounting surface. Depending on the travel length, some disks will not be used.

Index

- Acceleration
 - Limits, 30
 - Maximum, 12
- Accuracy, 33
 - Straightline, 12
 - Thermal Effects, 33
- Assembly Diagrams, 8, 38
- Bearing
 - Life, 13, 30
 - Linear, 30, 31
 - Load, 13, 16
 - Lubrication, 41
 - Support, 13
- Bend Radius, 29
- Cable Transport Module
 - Encoder Connections, 25
 - Limit and Home
 - Connections, 25
 - Motor Connections, 24
- Cabling, 29
 - Cable Carriers, 29
 - Cable Management, 10
 - Cable Transport Module, 22, 29
 - Replacement, 41
 - OEM Cable System, 24, 29
- Clean Room Preparation, 18
- Compensation
 - Thermal Effects, 35
- Deceleration Distance, 27
- Dimensional Drawings, 11
- Drive Amplifier, 10
- Electrical Specifications, 19
- Encoder, 5, 28, 29, 31, 33, 41
 - Accuracy, 31
 - Connections, 25
 - Limit, 31
 - Options, 10
 - Resolution, 31
 - Specifications, 20
 - Wires, 37
- Force
 - Maximum Continuous, 12
 - Peak Maximum, 12
- Force/Speed Charts, 18
- Gemini
 - Adapter Cable**, 37
 - Drive Specifications, 20
- General Table Specifications, 12
- Grounding, 28
- Hall Effect, 29, 37, 45
 - Signal Wires, 37
 - Specifications, 20
- Home Sensor
 - Connections, 25
 - Replacement, 43
 - Setting, 28
 - Specifications, 21
- Home Switch, 10
- Horizontal Translation, 16
- Ingress Protection Rating, 46
- Internal Access Procedure, 39
- Internal Protection, 46
- Limit Sensor
 - Connections, 25
 - Replacement, 43
 - Specifications, 21
- Limit Switch, 10
- Linear Motor, 44
 - Specifications, 19
- Lubrication, 39, 41
- Maintenance, 39
- Maximum Obtainable
 - Deceleration Rate, 27
- Motor Connections, 24
- Motor Force, 30
- Motor Heating, 34
- Mounting, 10
 - Inverted, 27
 - Methods, 26
 - Side, 27
 - Surface Requirements, 26
- OEM Cabling, 24
- Order Number Nomenclature, 10
- Overhang, 26
- Pinning, 10
- Product Rating, 47
- Repair Information, 6
- Repeatability, 28
 - Positional, 12
 - Thermal Effects, 34
- Return Information, 6
- Settling Time, 30
- Shielding, 28
- Slope
 - Correction, 31, 33
 - Error, 32, 33
- Speed
 - Limits, 31
 - Maximum, 27
- Table Load, 13
- Temperature Switch, 37
- Thermal Effects
 - Accuracy, 33
 - Causes, 34
 - Compensation, 35
 - Compensation Equation, 35
 - Repeatability, 34
- Toe Clamps, 26
- Travel, 10
 - Setting Limit Sensors, 27
- Unpacking, 5
- Velocity
 - Maximum, 12, 31
- Warnings, 6, 46
- Weight
 - Carriage, 12
 - Unit, 12
- Wiring Diagrams, 22
- Z Channel, 10, 28
- Zero Position, 32