



Belt Driven Positioners

Belt-driven actuators are ideal for high speed, industrial automation applications. These positioners are used in either single or multi-axis configurations such as gantry robots, and are ideal for applications such as palletizing, storage and retrieval, machine loading, parts handling, material handling and automated assembly. Parker offers a wide array of belt driven positioners with thousands of configurable options that are able to scale to solve virtually any automation application. Parker can construct these positioners into complete motion systems, integrating motors, drives, controls, HMI, cable management, machine frames and guarding. Contact your Parker application engineering expert to help construct a complete system to fit your needs.

Parker Belt Driven Industrial Systems

Product Comparisons: Parker high-speed belt driven actuators are segmented into specific series that are distinguished by guidance technology as well as frame size and corresponding loading properties. All products are able to be pre-configured with Parker motor and gearheads or common industry mounting options.

HMR High Moment Rodless Series Industrial Belt Driven Positioners



The user-friendly and versatile HMR has enormous moment and payload capacity bundled in a low-profile, yet sleek package. The HMRB is ideal for long travel lengths and high speed dynamic positioning.
Page 159.

OSPE..BHD Series Belt-Driven Positioners



The OSPE..BHD offers a compact design ideal for high-speed, long travel, heavy duty applications requiring robustness, dynamic precision, and extraordinary performance.
Page 190.

OSPE..B Series Belt-Driven Positioners



Ideal for precise point-to-point applications, the OSPE..B offers high-speed operation, easy installation, and low maintenance.
Page 207.

OSPE..BV Series Belt-Driven Positioners



Robust and compact, the OSPE..BV is a vertical fixed belt-driven actuator with integrated ball bearing guide designed to lift loads in a vertical orientation.
Page 229.

Continued next page...

Belt Driven Positioners

Continued from previous page...

LCR Series Light-Capacity Belt-Driven Positioners



The LCR Series is a completely pre-engineered, pre-tested, ready-to-use positioner solution for unmatched, easy-to-use flexibility.
Page 235.

HPLA Belt-Driven Linear Modules



Strong and rugged, the HPLA is a "next generation" linear module. The series offers high speed, high acceleration, and long travel, combined with stiff, rigid construction characteristics.
Page 247.

HLE-RB Belt-Driven Linear Modules



The HLE line is a proven performer offering long life and trouble-free operation, ideal as single axis products or as components for high speed multi-axis gantries. Roller Bearing system.
Page 261.

HLE-SR Belt-Driven Linear Modules



The HLE line is a proven performer offering long life and trouble-free operation, ideal as single axis products or as components for high speed multi-axis gantries. Square Rail bearing system.
Page 276.

HZR Vertical-Axis Belt Driven Positioners



The HZR is a rugged vertical axis unit unique to the high speed automation industry designed for mechanical demands placed on the vertical axis of a multi-axis gantry robot.
Page 287.

HPLA/HLE/HZR Options & Accessories

Page 303.

Additional Capabilities: Gantry Systems

Page 293.

Parker's gantry systems provide cost-effective, easy to integrate solutions that satisfy the vast majority of automation requirements. In addition to these standard gantry systems, Parker offers products with additional capabilities to fulfill the needs of special applications. Our engineering skill and manufacturing expertise have integrated these products into custom-tailored gantry solutions which have successfully addressed the most unique and exacting requirements of machine builders and integrators around the world.



The HMRB Series

HMRB Belt-Driven Actuators
for High Speed, High Payload Positioning Applications

Belt Driven
Tables

- High dynamic control for precision positioning
- High payload capacity
- High speed operation
- Easy installation
- Highly configurable design
- Ideal in multi axis applications



Features

- 5 different frame sizes to choose from
- Basic or reinforced profiles for supported or unsupported applications
- Tandem carriage with second carriage for higher load capabilities
- Bi-parting carriage for centering applications
- Long available strokes
- Complete motor and drive packages
- Ambient operating temperature range -20°C to +80°C
- IP 54 Rating



	HMRB08	HMRB11	HMRB15	HMRB18	HMRB24
Maximum Travel (mm)	3000	4000	5800	5800	5800
Maximum Payload (N)	1800	4450	8800	16200	26600
Maximum Acceleration (m/sec ²)	10	10	10	10	10

The HMRB is the belt driven version in the HMR family. The steel reinforced timing belt used on this positioner features a round tooth profile for greater energy

efficiency and smoother overall motion, as compared to traditional belt profiles. The HMRB is ideal for long travel lengths and high speed dynamic positioning.

The compact design allows integration of the HMRB in any machine layout, providing superior dynamic performance with minimal space utilization.

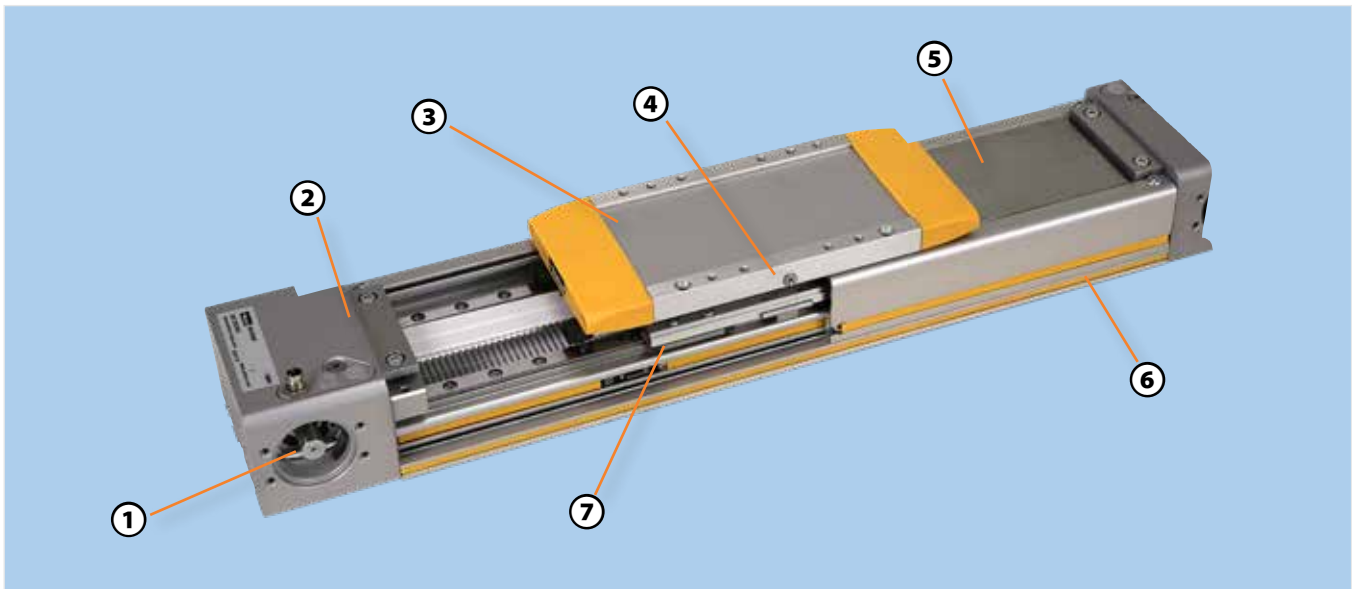

- ① **Drive shaft**
Designed to pair with a large assortment of motor and gearhead options
- ② **Steel reinforced timing belt**
High thrust force transmission and long life
- ③ **Carriage assembly**
Low profile, high strength aluminum construction with threaded and pinning mounting options
- ④ **Lubrication ports**
Easy access maintenance (1x per side) allows for single point lubrication for all bearing trucks and the ball nut at any location along travel
- ⑤ **Corrosion resistant steel sealing band**
Magnetically fastened to the actuator body and provides IP54 sealing
- ⑥ **Slotted profile**
Dovetail grooves for actuator & sensor mounting
- ⑦ **Recirculating profile rail bearing**
Two rails and four bearing trucks total for maximized payload capacity

Profile Options

Basic profile - for applications where actuator is fully supported, this option provides a lower profile option.

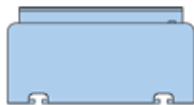

Reinforced profile - for long unsupported spans (i.e. gantry style applications).

Carriage Options

Standard carriage or tandem carriage for higher load capabilities



Cover Options

IP20 rated without protective cover, or IP54 rated protective cover with seal strip cover assemblies—ideal for harsh environments



Motor Mounting Options

The HMRB belt driven positioner is designed to optimize flexibility in machine design. As such the drive and motor mounting can be positioned at any one of four different positions around the axis of motion. This option is configurable through the part number.



Multi-axis Systems

A wide range of adapter plates and intermediate drive shafts simplifies engineering and installation.
**Please consult factory for your individual system design.*

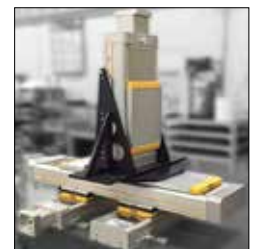

Other Options & Accessories

HMRB actuators can be outfitted with a variety of different options.

In addition to the standard configurable options highlighted in Options & Accessories, a list of commonly used non-standard options are highlighted below. Please contact us for assistance in choosing any of these or any other unique configurations.

- **Dual axis with link shaft**
- **Purge ports**
- **Parallel motor mount**
- **Longer than cataloged stroke**
- **...and many more**



SPECIFICATIONS

Parker Hannifin's High Moment Rodless (HMR) Series electric linear actuator is one of the most user friendly and versatile actuator lines on the market today. Guided by two square rail bearings, the HMR has enormous moment and payload capacity bundled in a low-profile, yet sleek package. With five different frame sizes, two different drive train options, multiple mounting, carriage and sensor options, and an IP54 protective cover option—along with a multitude of other customizable features—the HMR was truly designed with flexibility in mind.



Common Specifications

Actuator Size			HMRB08				HMRB11			
Belt drive orientation			090°/270°		000°/180°		090°/270°		000°/180°	
Travel Distance per Revolution	S_{lin}	mm	66				90			
Pulley Diameter		mm	21.01				28.65			
Linear Speed (Max)	v_{max}	m/s					2			
Acceleration (Max)	a_{max}	m/s ²					30			
Repeatability (unidirectional)		μm					± 50			
Order Stroke (Max) ⁽¹⁾		mm	3000				4000			
Thrust Force (Max)	F_{Amax}	N	295				630			
		lbs	66				142			
Thrust force (F_A)- corresponding to velocity (v)	F_A	(v<1 m/s) N	295				630			
		(v<2 m/s) N	295				550			
		(v<3 m/s) N	-				-			
		(v<4 m/s) N	-				-			
		(v<5 m/s) N	-				-			
Thrust force (F_A)- corresponding to order stroke (OS)	F_A	(OS<1 m) N	250				630			
		(OS<2 m) N	140				550			
		(OS<3 m) N	100				385			
		(OS<4 m) N	-				295			
		(OS<5 m) N	-				-			
Torque on Drive Shaft (Max)	M_{Amax}	Nm	3.1				9.0			
		in-lb	27.4				80.0			
Torque ⁽²⁾ — No Load	M_0	Nm	1.0				1.2			
		in-lb	8.9				10.6			
Inertia										
@ Zero Stroke	J_0	kgmm ²	14				52			
Per Meter of Stroke	J_{OS}	kgmm ² /m	10				41			
Per 1 kg Moved Mass	J_m	kgmm ² /kg	110				205			
Unit Weight (by Order Code Option)			B	C	R	S	B	C	R	S
@ Zero Stroke	m_0	kg	2.4	2.7	3.1	3.4	4.4	4.8	6.1	6.5
Per Meter of Stroke	m_{OS}	kg/m	3.0	4.0	4.0	5.0	5.4	6.4	7.6	8.6
Carriage (by Order Code Option) ⁽³⁾	m_C	kg	0		1		0		1	
			0.9		0.7		1.7		1.3	
Ambient Temperature Range							-20 to +80			
IP Rating ⁽⁴⁾							IP 54			

Note- For force and moment load specifications, see HMRB Loading Conditions

⁽¹⁾ Longer lengths available - please consult factory

⁽²⁾ For tandem and bi-parting options, double the listed values

⁽³⁾ For tandem and bi-parting carriage weight add mass from column '0' and '1'

⁽⁴⁾ For unit with protective covers - IP20 without covers

Common Specifications

Actuator Size			HMRB15				HMRB18				HMRB24																					
Belt drive orientation			090°/270°		000°/180°		090°/270°		000°/180°		090°/270°		000°/180°																			
Travel Distance per Revolution	S_{lin}	mm	100		125		130		150		160		224																			
Pulley Diameter		mm	31.83		39.79		41.38		47.74		50.93		71.30																			
Linear Speed (Max)	v_{max}	m/s	5																													
Acceleration (Max)	a_{max}	m/s ²	50																													
Repeatability (unidirectional)		µm	± 50																													
Order Stroke (Max) ⁽¹⁾		mm	5800																													
Thrust Force (Max)	F_{Amax}	N	1050		630		1300		1000		4000		3750																			
		lbs	236		142		292		225		899		843																			
Thrust force (F_A)- corresponding to velocity (v)	F_A	(v<1 m/s) N	1050		630		1300		1000		4000		3750																			
		(v<2 m/s) N	990		630		1300		1000		4000		3380																			
		(v<3 m/s) N	930		630		1300		1000		3650		3140																			
		(v<4 m/s) N	890		630		1300		1000		3370		2950																			
		(v<5 m/s) N	840		630		1300		1000		3200		2800																			
Thrust force (F_A)- corresponding to order stroke (OS)	F_A	(OS<1 m) N	1050		630		1300		1000		4000		3750																			
		(OS<2 m) N	820		490		1000		775		4000		3360																			
		(OS<3 m) N	570		340		710		550		3370		2440																			
		(OS<4 m) N	445		265		550		430		2860		1880																			
		(OS<5 m) N	365		215		450		350		2350		1540																			
Torque on Drive Shaft (Max)	M_{Amax}	Nm	17.0		13.0		27.0		24.0		101.0		134.0																			
		in-lb	150.5		115.1		239.0		212.4		894.0		1186.0																			
Torque ⁽²⁾ — No Load	M_0	Nm	1.2				2.0				5.5																					
		in-lb	10.6				17.7				48.7																					
Inertia		@ Zero Stroke	J_0	kgmm ²		102		145		297		394		1178		2758																
		Per Meter of Stroke	J_{OS}	kgmm ² /m		79				134		222		689		900																
		Per 1 kg Moved Mass	J_m	kgmm ² /kg		253		396		428		570		649		1271																
Unit Weight (by Order Code Option)					B	C	R	S	B	C	R	S	B	C	R	S																
																	@ Zero Stroke	m_0	kg		6.7	7.5	9.4	10.3	11.6	12.8	15.6	16.7	21.5	23.1	28.0	29.6
																	Per Meter of Stroke	m_{OS}	kg/m		8.2	9.9	11.5	13.3	12.8	15.1	16.5	18.7	21.6	24.4	26.7	29.5
																	Carriage (by Order Code Option) ⁽³⁾	m_C	kg		0		1		0		1		0		1	
Ambient Temperature Range		°C	-20 to +80																													
IP Rating ⁽⁴⁾			IP 54																													

Note- For force and moment load specifications, see HMRB Loading Conditions

⁽¹⁾ Longer lengths available - please consult factory

⁽²⁾ For tandem and bi-parting options, double the listed values

⁽³⁾ For tandem and bi-parting carriage weight add mass from column '0' and '1'

⁽⁴⁾ For unit with protective covers - IP20 without covers

Loading Specifications (Max)

Life and loading characteristics shown for both belt and screw driven units.

Rated Life			HMR08	HMR11
2540 km	F_Y / F_Z	N (lb)	1,800 (405)	4,450 (1,001)
2540 km Tandem	F_Y / F_Z	N (lb)	2,700 (608)	6,675 (1,508)
8000 km	F_Y / F_Z	N (lb)	1,250 (281)	3,000 (675)
8000 km Tandem	F_Y / F_Z	N (lb)	1,875 (422)	4,500 (1,013)
2540 km	M_X	Nm (in-lb)	45 (398)	155 (1,372)
	M_Y	Nm (in-lb)	80 (708)	200 (1,770)
	M_Z	Nm (in-lb)	80 (708)	200 (1,770)
2540 km Tandem	M_X	Nm (in-lb)	68 (602)	235 (2,080)
	M_Y	Nm (in-lb)	120 (1,062)	300 (2,655)
	M_Z	Nm (in-lb)	120 (1,062)	300 (2,655)
8000 km	M_X	Nm (in-lb)	30 (266)	105 (929)
	M_Y	Nm (in-lb)	55 (487)	135 (1,195)
	M_Z	Nm (in-lb)	55 (487)	135 (1,195)
8000 km Tandem	M_X	Nm (in-lb)	45 (398)	160 (1,416)
	M_Y	Nm (in-lb)	80 (708)	205 (1,814)
	M_Z	Nm (in-lb)	80 (708)	205 (1,814)

Belt Driven Tables

Rated Life			HMR15	HMR18	HMR24
2540 km	F_Y / F_Z	N (lb)	8,800 (1,980)	16,200 (3,645)	26,600 (5,985)
2540 km Tandem	F_Y / F_Z	N (lb)	13,200 (2,970)	24,300 (5,468)	39,900 (8,978)
8000 km	F_Y / F_Z	N (lb)	6,000 (1,350)	11,000 (2,475)	18,200 (4,095)
8000 km Tandem	F_Y / F_Z	N (lb)	9,000 (2,025)	16,500 (3,713)	27,300 (6,143)
2540 km	M_X	Nm (in-lb)	430 (3,806)	940 (8,320)	2,150 (19,029)
	M_Y	Nm (in-lb)	560 (4,956)	1,230 (10,886)	2,430 (21,507)
	M_Z	Nm (in-lb)	560 (4,956)	1,230 (10,886)	2,430 (21,507)
2540 km Tandem	M_X	Nm (in-lb)	645 (5,708)	1,410 (12,480)	3,225 (28,544)
	M_Y	Nm (in-lb)	840 (7,435)	1,845 (16,330)	3,645 (32,261)
	M_Z	Nm (in-lb)	840 (7,435)	1,845 (16,330)	3,645 (32,261)
8000 km	M_X	Nm (in-lb)	290 (2,567)	640 (5,664)	1,460 (12,922)
	M_Y	Nm (in-lb)	380 (3,363)	840 (7,435)	1,660 (14,692)
	M_Z	Nm (in-lb)	380 (3,363)	840 (7,434)	1,660 (14,692)
8000 km Tandem	M_X	Nm (in-lb)	435 (3,850)	960 (8,497)	2,190 (19,383)
	M_Y	Nm (in-lb)	570 (5,045)	1,260 (11,152)	2,490 (22,038)
	M_Z	Nm (in-lb)	570 (5,045)	1,260 (11,152)	2,490 (22,038)





Weight, Mass, and Inertia

Weight and mass HMRB

Product size		HMRB08				HMRB11				HMRB15			
		Weight of actuator											
Version actuator (see order code)		B	C	R	S	B	C	R	S	B	C	R	S
Weight. 0 - order stroke	m_0 [kg]	2.4	2.7	3.1	3.4	4.4	4.8	6.1	6.5	6.7	7.5	9.4	10.3
Weight per 1 m order stroke	m_{mt} [kg/m]	3.0	4.0	4.0	5.0	5.4	6.4	7.6	8.6	8.2	9.9	11.5	13.3
		Moving mass carrier											
Version of carriage (see order code)		0		1		0		1		0		1	
Weight carriage*	m_c [kg]	0.9		0.7		1.7		1.3		2.7		1.9	

Weight and mass HMRB

Product size		HMRB18				HMRB24			
		Weight of actuator							
Version actuator (see order code)		B	C	R	S	B	C	R	S
Weight. 0 - order stroke	m_0 [kg]	11.6	12.8	15.6	16.7	21.5	23.1	28.0	29.6
Weight per 1 m order stroke	m_{mt} [kg/m]	12.8	15.1	16.5	18.7	21.6	24.4	26.7	29.5
		Moving mass carrier							
Version of carriage (see order code)		0		1		0		1	
Weight carriage*	m_c [kg]	4.6		3.7		9.0		7.2	

*For tandem and bi-parting carriage weight add mass from column '0' and '1'

Total mass HMRB: $m_{tot} = m_0 + m_c + \text{order stroke} * m_{mt}$

Inertia HMRB

Product size		HMRB08		HMRB11		HMRB15	
Motor mounting position (see order code)		090°/270°	000°/180°	090°/270°	000°/180°	090°/270°	000°/180°
Inertia							
Inertia 0 - order stroke	J_0 [kgmm ²]	14	14	52	52	102	145
Inertia per 1 m order stroke	J_{mt} [kgmm ² /m]	10	10	41	41	79	79
Inertia per 1 kg moving mass	J_{kg} [kgmm ² /kg]	110	110	205	205	253	396

Inertia HMRB

Product size		HMRB18		HMRB24	
Motor mounting position (see order code)		090°/270°	000°/180°	090°/270°	000°/180°
Inertia					
Inertia 0 - order stroke	J_0 [kgmm ²]	297	394	1,178	2,758
Inertia per 1 m order stroke	J_{mt} [kgmm ² /m]	134	222	689	900
Inertia per 1 kg moving mass	J_{kg} [kgmm ² /kg]	428	570	649	1,271

Inertia total HMRB: $J_{tot} = J_0 + \text{order stroke} * J_{mt} + m_c * J_{kg} + m * J_{kg}$

HMR Loading Conditions

Loading conditions, including external forces and moment loading, are application dependent. The center of gravity for the mass/payload attached to the carriage must be determined in order to properly size the ideal actuator for your application. Please note that when selecting the proper HMR actuator for your system the sum of all loading should not exceed "1" as per the formula below.

Loads, forces, and bending moments

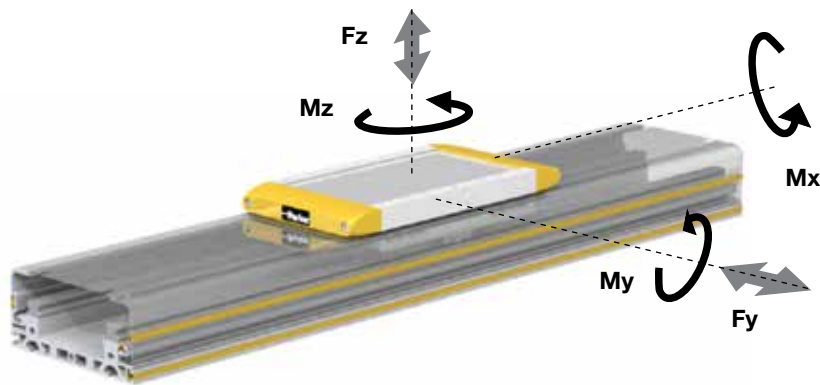

Calculating Load Factors - Combined Normal and Moment Load

The sum of combined loads (static and dynamic) must not exceed "1" at any time as shown in the formula below:

$$L = \frac{F_y}{F_{y(max)}} + \frac{F_z}{F_{z(max)}} + \frac{M_x}{M_{x(max)}} + \frac{M_y}{M_{y(max)}} + \frac{M_z}{M_{z(max)}} \leq 1$$

$M = F \times d$ (Nm)
 $M_x = M_{x \text{ static}} + M_{x \text{ dynamic}}$
 $M_y = M_{y \text{ static}} + M_{y \text{ dynamic}}$
 $M_z = M_{z \text{ static}} + M_{z \text{ dynamic}}$

Internal lever arm l_{zi}

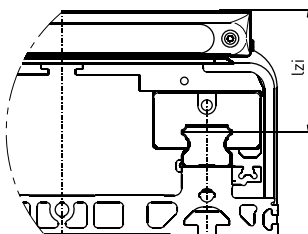

Dimensions - Internal lever arm l_{zi}

Product size	l_{zi}
HMRx085	[mm] 33.0
HMRx110	[mm] 39.5
HMRx150	[mm] 50.0
HMRx180	[mm] 57.5
HMRx240	[mm] 68.0

Maximum Permissible Unsupported Length — *Determining actuator mounting placement*

HMR Series actuators need to be mounted onto a solid machine base or frame structure using appropriately positioned actuator mounts. This ensures that the actuator will not undergo excessive deflection based on the application's load and length requirements.

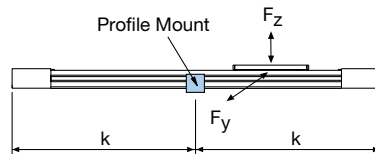

The greater the load and/or the longer the unsupported length between mounts, the more the actuator is susceptible to deflection.

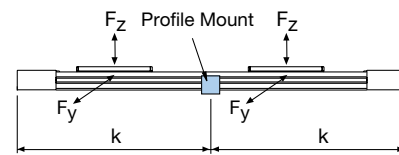

Deflection is also dependent on the carriage orientation (F_z for standard mounted actuator or F_y for a side mounted actuator).

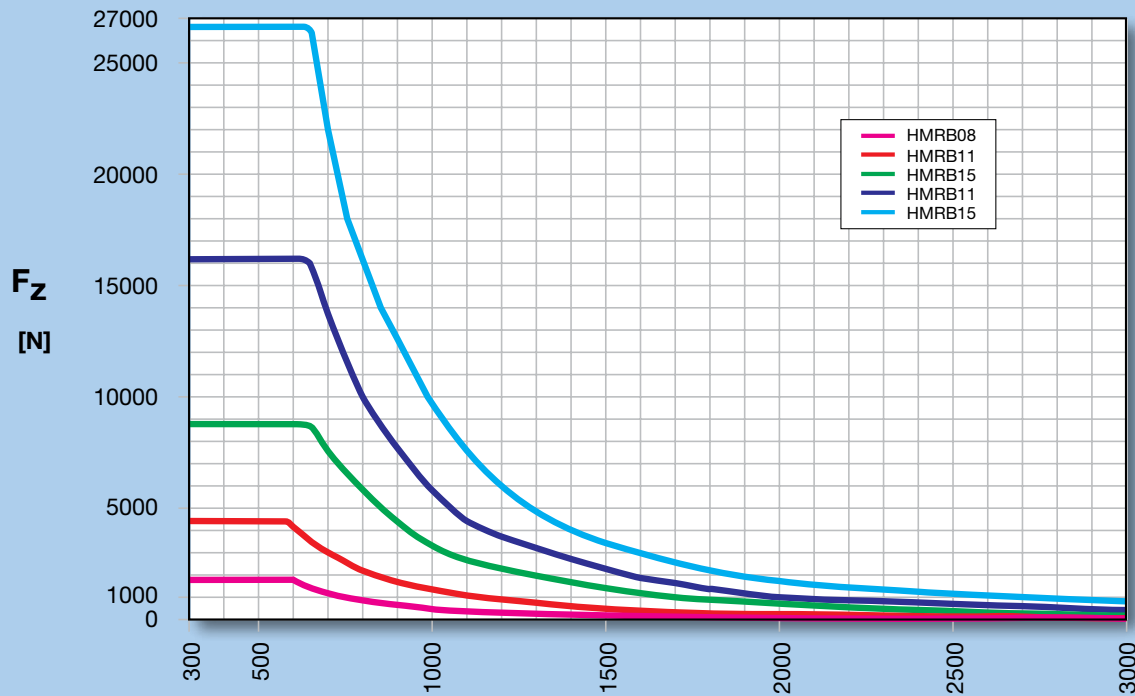

Example F_z HMR 11:

For a 3160 N load, the distance "d" between supporting elements is 700 mm. For mounting accessories see "Actuator Mounting" in Options & Accessories.

Maximum Permissible Unsupported Length — *Determining actuator mounting placement*

Use the appropriate deflection graph to ensure that the application load does not exceed the deflection curve. Supporting the actuator within the recommended maximum distance “k” will ensure that the installation will have a maximum deflection equal to 0.01% of distance “k.”

To further reduce deflection, simply reduce the distance between actuator mounts as described in the examples below.



Maximum admissible loads [N] and supporting distances [mm] (self-supporting- reinforced profile only)

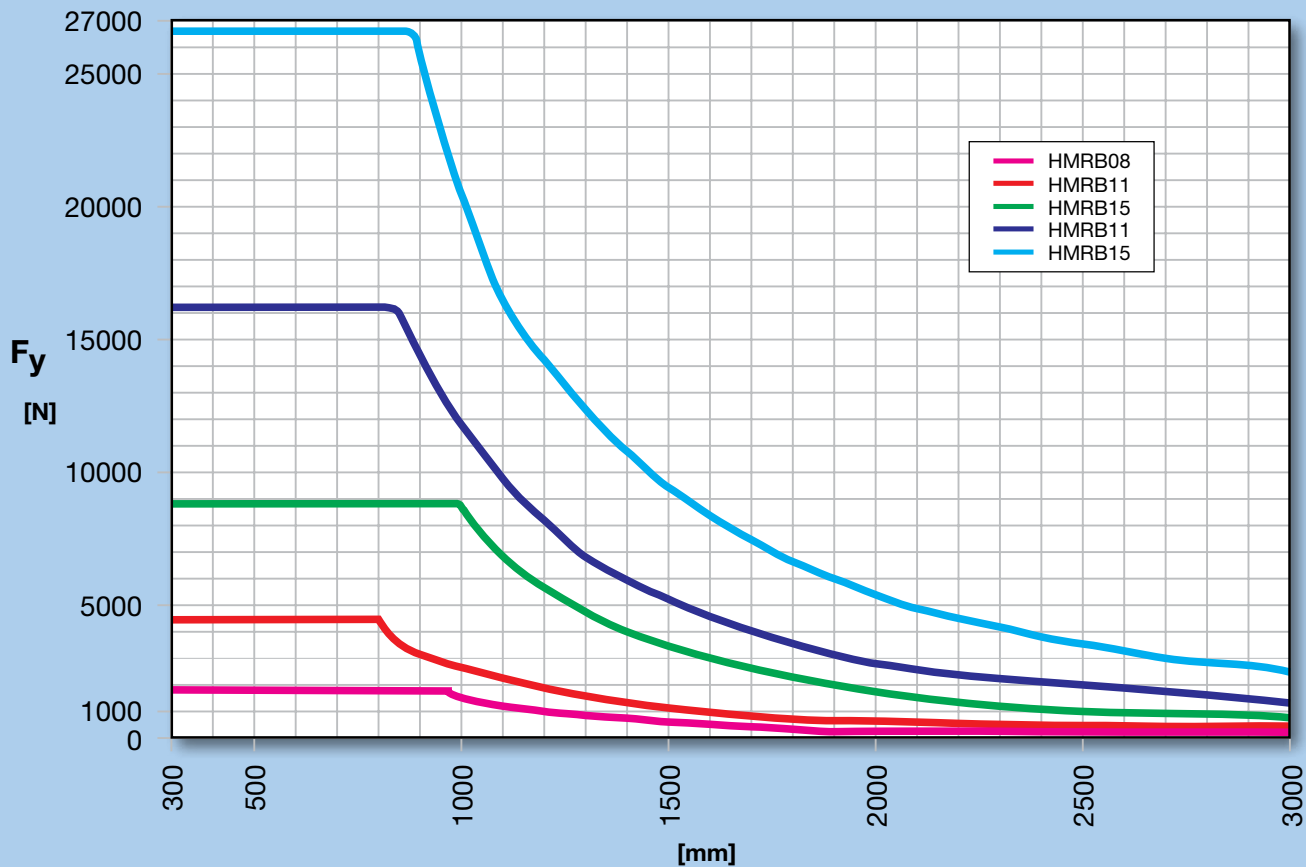

Example F_y HMR 11:

For a 3160 N load, the distance “d” between supporting elements is 900 mm.
For mounting accessories see “Actuator Mounting” in Options & Accessories.

DIMENSIONS

Dimensions – (mm)

HMR actuators can be configured with either "Basic" or "Reinforced" profiles based on applications demands. Basic profiles are suitable for applications where the actuator is secured to a machine base and constantly supported. Reinforced profiles can be utilized in applications with unsupported spans. See Maximum Permissible Unsupported Length for mounting support instructions.

Dimensions - (000°/180° option shown)

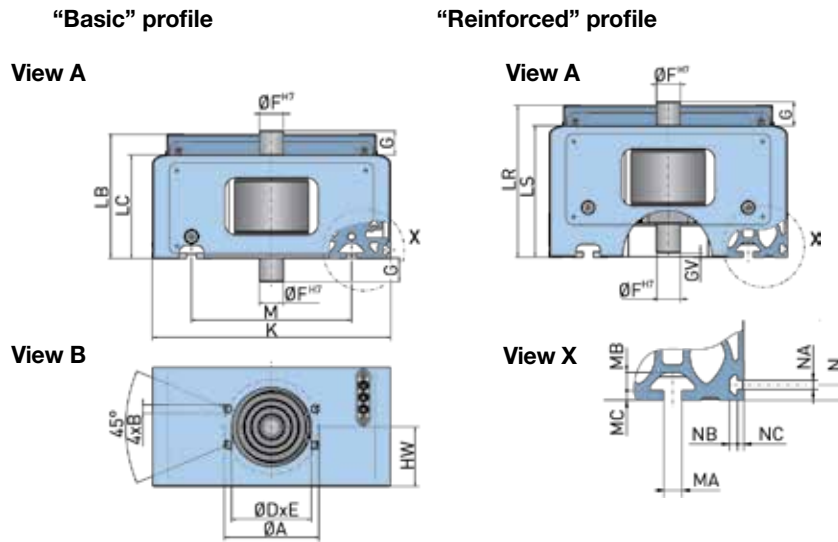

Dimensions carrier

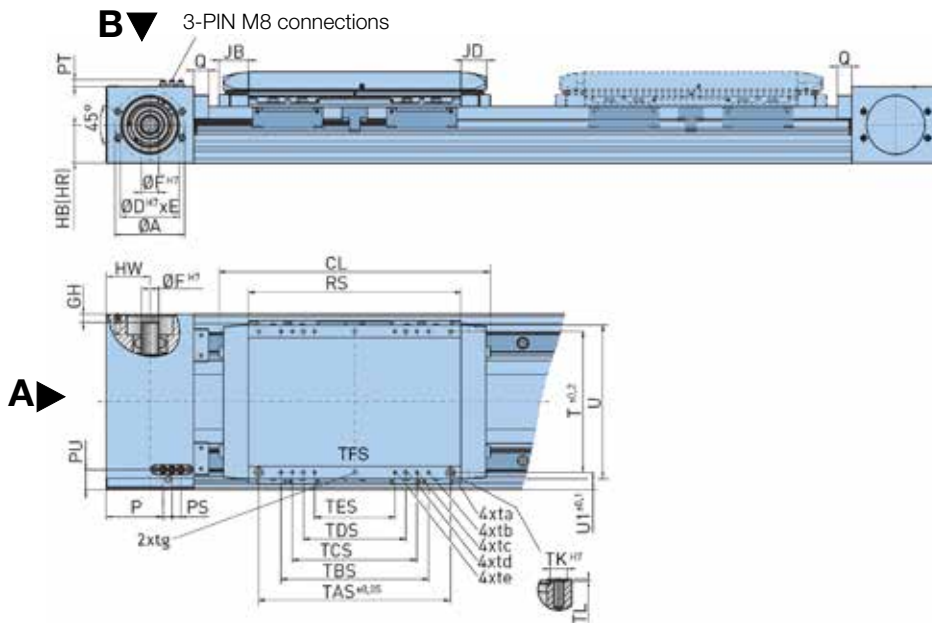

Free sizing and selection support
from Virtual Engineer at
parker.com/VirtualEngineer





Dimensions – (mm)

Dimension table - HMRB

Size	Ø A	B	Ø D ^{H7}	E	Ø F ^{H7}	G	GV	GH	HB	HR	HW	K	LB	LC
HMRB08 [mm]	42.0	M4	34.0	2.5	10.0	13.5	2.5	3.0	26.5	37.5	25.0	85.0	60.0	52.5
HMRB11 [mm]	51.0	M6	39.0	1.2	12.0	20.0	0.0	5.0	30.0	50.0	31.0	110.0	69.5	60.5
HMRB15 [mm]	72.0	M8	54.0	2.1	15.0	19.3	7.0	5.5	36.5	60.5	45.0	150.0	90.0	74.0
HMRB18 [mm]	80.0	M8	64.0	4.0	18.0	21.8	1.5	8.0	45.0	68.0	50.0	180.0	111.5	93.5
HMRB24 [mm]	95.0	M10	80.0	2.5	24.0	24.0	4.0	11.0	52.5	80.5	60.0	240.0	125.0	104.5

Dimension table - HMRB

Product size	LR	LS	M	MA	MB	MC	N	NA	NB	NC	P	PS	PT	PU	Q
HMRB08 [mm]	71.0	63.5	50.0	5.2	4.5	1.5	4.5	3.4	3.0	2.5	23.8	12.0	9.0	12.0	16.0
HMRB11 [mm]	89.5	80.5	70.0	5.2	4.5	1.8	4.5	3.4	3.0	2.5	30.8	12.0	9.0	17.0	20.0
HMRB15 [mm]	114.0	98.0	96.0	6.2	6.8	3.0	6.5	5.2	4.6	3.5	48.0	12.0	9.0	21.0	20.0
HMRB18 [mm]	134.5	116.5	116.0	8.0	7.8	4.5	8.5	5.2	4.5	3.5	58.0	12.0	9.0	28.0	20.0
HMRB24 [mm]	153.0	132.5	161.0	10.0	10.2	5.3	8.5	5.2	4.5	3.5	78.0	12.0	9.0	28.6	20.0

Dimension table - carriage standard HMRB

Product size	JB	JD	CL	RS	T	TAS	ta	TBS	tb	TCS	tc	TDS	td	TES
HMRB08 [mm]	33.5	30.0	195.0	128.0	74.0	97.0	M4x12	70.0	M4x12	40.0	M4x12	-	-	-
HMRB11 [mm]	37.5	34.0	225.0	150.0	96.0	122.0	M5x12	97.0	M5x12	65.0	M5x12	25.0	M5x12	-
HMRB15 [mm]	37.5	34.0	266.0	191.0	120.0	170.0	M5x12	122.0	M5x12	110.0	M5x12	70.0	M5x12	-
HMRB18 [mm]	40.0	34.0	311.0	231.0	150.0	202.0	M6x12	170.0	M5x10	122.0	M5x10	110.0	M5x12	90.0
HMRB24 [mm]	40.0	34.0	371.0	291.0	192.0	262.0	M8x16	202.0	M6x12	170.0	M5x10	140.0	M8x16	122.0

Dimension table - carriage standard HMRB

Product size	te	TFS	tf	tg	ØTKH7	TL	U	U1
HMRB08 [mm]	-	-	-	-	7.0	1.5	83.0	5.5
HMRB11 [mm]	-	-	-	-	7.0	1.5	105.0	7.0
HMRB15 [mm]	-	-	-	M5x12	7.0	1.5	135.0	15.0
HMRB18 [mm]	M6x12	-	-	M6x12	9.0	1.5	165.0	15.0
HMRB24 [mm]	M5x10	110.0	M5x12	M8x16	12.0	1.5	210.0	24.0

Dimensions – mm

Stroke depending dimensions

- ES = Effective Stroke
- SS = Safety Stroke
- CD = Carriage distance
- CL = Carriage length Standard
- S = Stroke
- OS = Order Stroke
- OAL = Over All Length

Option Carrier Standard

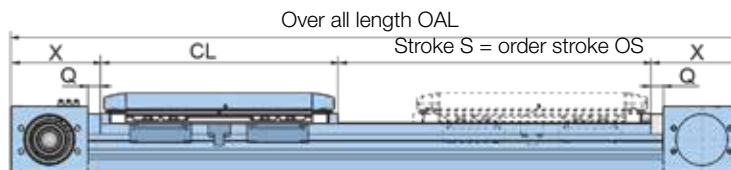

Order stroke OS = Effective stroke ES + 2 x Safety stroke SS
Over all length OAL = Order stroke OS + Carrier length CL + 2 x End cap length X

Option Carrier Tandem

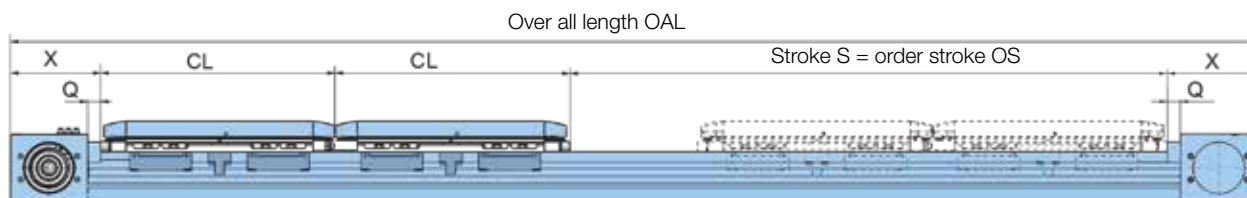

Order stroke OS = Effective stroke ES + 2 x Safety stroke SS + Carrier distance CD (not shown)
Over all length OAL = Order stroke OS + 2 x Carrier length CL + 2 x End cap length X

Option Carrier Bi-part for opposite movements

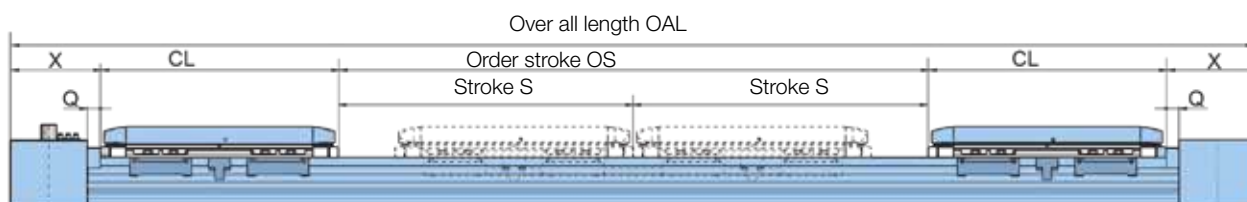

Order stroke OS = 2 x Stroke S = 2 x Effective stroke ES + 4 x Safety stroke SS + Carrier distance CD (not shown)
Over all length OAL = Order stroke OS + 2 x Carrier length CL + 2 x End cap length X

Dimensions - Carriage and end cap HMRB

Product size	CL	Q	X
HMRB08 [mm]	195.0	16.0	74.0
HMRB11 [mm]	225.0	20.0	85.0
HMRB15 [mm]	266.0	20.0	110.0
HMRB18 [mm]	311.0	20.0	120.0
HMRB24 [mm]	371.0	20.0	140.0

OPTIONS & ACCESSORIES

Gearhead Mounting Kit Options

Gearhead Mounting Kits include a coupling housing, coupling, and flange.

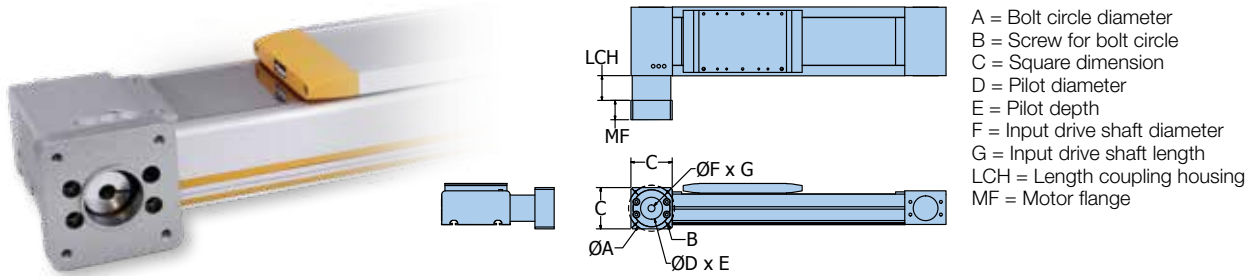

- A = Bolt circle diameter
- B = Screw for bolt circle
- C = Square dimension
- D = Pilot diameter
- E = Pilot depth
- F = Input drive shaft diameter
- G = Input drive shaft length
- LCH = Length coupling housing
- MF = Motor flange

(see page 257 for LCH dimensions)

Actuator Size	① Order Code ¹	Dimensions							
		A	B	C	D	E	F	G	MF
HMRB08	C0	44	M4x0.7	60	35	6	12	25	20
HMRB11	A7	70	M5x0.8	60	50	15	16	40	35
	C0	44	M4x0.7	60	35	6	12	25	20
	C1	62	M5x0.8	80	52	8	16	40	35
	BX	70	M5x0.8	60	50	10	16	25	20
HMRB15	A7	70	M5x0.8	85	50	15	16	40	30
	A8	100	M6x1	90	80	20	22	52	42
	C1	62	M5x0.8	84	52	12	16	36	30
	C2	80	M6x1	92	68	5	22	46	36
	BX	70	M5x0.8	85	50	5	16	25	20
	BY	100	M6x1	92	80	15	20	40	30
HMRB18	A8	100	M6x1	100	80	30	22	52	40
	C2	80	M6x1	92	68	6	22	46	30
	BY	100	M6x1	92	80	15	20	40	30
	BZ	130	M8x1.25	115	110	25	24	50	40
HMRB24	A9	130	M8x1.25	115	110	25	32	68	40
	C3	108	M8x1.25	125	90	17	32	70	40
	BZ	130	M8x1.25	115	110	5	24	50	20

¹ When ordering with actuator, use order code ① to specify appropriately sized gearhead mounting kit, and order code ③ to specify drive shaft orientation. See Ordering Information.

Mounted Gearhead with Motor Mounting Kit Options

Mounted Gearhead with Motor Mounting Kits include a coupling housing, coupling, flange, and gearhead with coupler and flange.

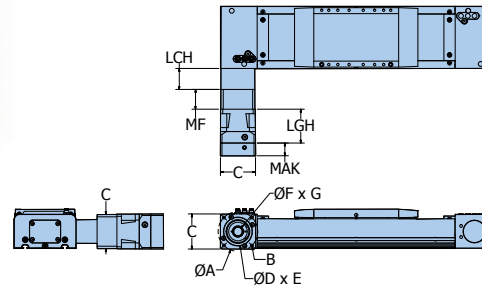

- A = Bolt circle diameter
- B = Screw for bolt circle
- C = Square dimension
- D = Pilot diameter
- E = Pilot depth of the flange
- F = Input drive shaft diameter
- G = Input drive shaft length
- LCH = Length coupling housing
- LGH = Length gearhead
- MAK = Motor adapter
- MF = Motor flange

(see page 257 for LCH dimensions)

Actuator Size	⑨	⑩	A	B	C	D	E	F	G	LGH	MAK	MF
	Order Code ¹	Order Code ²										
HMRB08	Jx	AB	66.68	M4x0.7	55	38.10	3.5	6.35	20.8	48.5	15.7	20
	Jx	AC	66.68	M5x0.8	57	38.11	6	9.53	20.8	48.5	26	20
	Jx	AD	66.68	M5x0.8	57	38.11	6	9.53	31.8	48.5	26	20
	Jx	B6	63	M5x0.8	55	40.05	8	9	23	48.5	19	20
HMRB11	Fx	A3	100	M6x1	82	80	5	14	30	59.8	18	35
	Fx	AB	66.68	M4x0.7	62	38.10	4	6.35	20.8	59.8	16.5	35
	Fx	AC	66.68	M5x0.8	62	38.15	4	9.53	20.8	59.8	16.5	35
	Fx	AD	66.68	M5x0.8	62	38.15	4	9.53	31.8	59.8	16.5	35
	Fx	AE	98.43	M5x0.8	86.8	73.03	7	12.70	37.1	59.8	22.5	35
	Fx	AF	98.43	M5x0.8	86.8	73.03	7	12.70	31.8	59.8	22.5	35
	Fx	AH	63	M5x0.8	62	40	4	9	23	59.8	16.5	35
	Fx	AN	70	M5x0.8	62	50	4	14	30	59.8	16.5	35
	Fx	B6	63	M4x0.7	62	40	4	9	23	59.8	16.5	35
	Jx	AB	66.68	M4x0.7	55	38.10	3.5	6.35	20.8	48.5	15.7	20
	Jx	AC	66.68	M5x0.8	57	38.11	6	9.53	20.8	48.5	26	20
	Jx	AD	66.68	M5x0.8	57	38.11	6	9.53	31.8	48.5	26	20
	Jx	B6	63	M5x0.8	55	40	8	9	23	48.5	19	20
	Kx	AB	66.68	M4x0.7	62	38.10	4	6.35	20.8	67	16.5	35
	Kx	AC	66.68	M4x0.7	62	38.10	4	9.53	20.8	67	16.5	35
	Kx	AD	66.68	M5x0.8	62	38.10	8.5	9.53	31.8	67	22.5	35
	Kx	AE	98.43	M6x1	85	73.05	10	12.70	37.1	67	30	35
	Kx	AF	98.43	M5x0.8	80	73.05	10	12.70	31.8	67	22.5	35
Kx	AH	63	M5x0.8	62	40	4	9	23	67	16.5	35	
Kx	AN	70	M5x0.8	62	50	11	14	30	67	22.5	35	
Kx	B6	63	M4x0.7	62	40	4	9	23	67	16.5	35	

¹ When ordering with actuator, use order code ⑨ (see Ordering Information) to specify mounted gearhead size, ratio and orientation:
 Gearhead size example: **F** = PS60 **G** = PS90 **H** = PS115 **J** = PV040TA **K** = PV60TA **L** = PV090TA **M** = PV115TA
 Gearhead ratio and mounting orientation: (Replace "x" to specify)
1 = ratio 3:1 **2** = ratio 5:1 **3** = ratio 10:1
 * 3:1 ratio not available on "J" PV040TA gearhead

² Use order code ⑩ (see Ordering Information) to specify appropriately sized motor mounting kit.

(continued on next page)

Mounted Gearhead with Motor Mounting Kit Options

(continued from previous page)

Actuator Size	⑨	⑩	A	B	C	D	E	F	G	LGH	MAK	MF
	Order Code ¹	Order Code ²										
HMRB15	Fx	A3	100	M6x1	82	80	5	14	30	59.8	18	30
	Fx	AB	66.68	M4x0.7	62	38.10	4	6.35	20.8	59.8	16.5	30
	Fx	AC	66.68	M5x0.8	62	38.15	4	9.53	20.8	59.8	16.5	30
	Fx	AD	66.68	M5x0.8	62	38.15	4	9.53	31.8	59.8	16.5	30
	Fx	AE	98.43	M5x0.8	86.8	73.03	7	12.70	37.1	59.8	22.5	30
	Fx	AF	98.43	M5x0.8	86.8	73.03	7	12.70	31.8	59.8	22.5	30
	Fx	AH	63	M5x0.8	62	40	4	9	23	59.8	16.5	30
	Fx	AN	70	M5x0.8	62	50	4	14	30	59.8	16.5	30
	Fx	B6	63	M4x0.7	62	40	4	9	23	59.8	16.5	30
	Gx	A2	63	M5x0.8	90	40	3	11	23	69.5	20	42
	Gx	A3	100	M6x1	90	80	10	14	30	69.5	20	42
	Gx	A4	115	M8x1.25	100	95	10	19	40	69.5	28.5	42
	Gx	AB	66.68	M5x0.8	90	38.15	3	6.35	20.8	69.5	20	42
	Gx	AC	66.68	M5x0.8	90	38.15	3	9.53	20.8	69.5	20	42
	Gx	AD	66.68	M5x0.8	90	38.15	3	9.53	31.8	69.5	20	42
	Gx	AE	98.43	M5x0.8	90	73.03	10	12.70	37.1	69.5	20	42
	Gx	AF	98.43	M5x0.8	90	73.07	10	12.70	31.8	69.5	20	42
	Gx	AH	63	M5x0.8	90	40	2.5	9	23	69.5	20	42
	Gx	AL	100	M6x1	90	80	10	16	40	69.5	20	42
	Gx	AN	70	M5x0.8	90	50	10	14	30	69.5	20	42
	Gx	AP	90	M6x1	90	70	10	19	40	69.5	20	42
	Gx	B1	90	M5x0.8	90	60	10	11	23	69.5	20	42
	Gx	B3	95	M6x1	90	50	10	14	30	69.5	20	42
	Gx	B6	63	M4x0.7	90	40	3	9	23	69.5	20	42
	Kx	AB	66.68	M4x0.7	62	38.1	4	6.35	20.8	67	16.5	30
	Kx	AC	66.68	M4x0.7	62	38.1	4	9.53	20.8	67	16.5	30
	Kx	AD	66.68	M5x0.8	62	38.1	8.5	9.53	31.8	67	22.5	30
	Kx	AE	98.43	M6x1	85	73.05	10	12.70	37.1	67	30	30
	Kx	AF	98.43	M5x0.8	80	73.05	7	12.70	31.8	67	22.5	30
	Kx	AH	63	M5x0.8	62	40	4	9	23	67	16.5	30
	Kx	AN	70	M5x0.8	62	50	4	14	30	67	22.5	30
	Kx	B6	63	M4x0.7	62	40	11	9	23	67	16.5	30
	Lx	A2	63	M5x0.8	90	40	3	11	23	85.5	20	36
	Lx	A3	100	M6x1	90	80	10	14	30	85.5	20	36
	Lx	A4	115	M8x1.25	100	95	10	19	40	85.5	28.5	36
	Lx	AB	66.68	M4x0.7	90	38.15	3	6.35	20.8	85.5	20	36
	Lx	AC	66.68	M5x0.8	90	52	10	9.53	20.8	85.5	20	36
	Lx	AD	66.68	M5x0.8	90	52	10	9.53	31.8	85.5	20	36
	Lx	AE	98.43	M5x0.8	90	73.03	10	12.70	37.1	85.5	28.5	36
	Lx	AF	98.43	M5x0.8	90	73	10	12.70	31.8	85.5	20	36
Lx	AH	63	M5x0.8	90	40	10	9	23	85.5		36	
Lx	AL	100	M6x1	90	80	10	16	40	85.5	28.5	36	
Lx	AN	70	M5x0.8	90	50	10	14	30	85.5	20	36	
Lx	AP	90	M6x1	90	70	10	19	40	85.5	28.5	36	

Belt Driven Tables

(continued from previous page)

Actuator Size	⑨	⑩	A	B	C	D	E	F	G	LGH	MAK	MF
	Order Code ¹	Order Code ²										
HMRB18	Gx	A2	63	M5x0.8	90	40	3	11	23	69.5	20	40
	Gx	A3	100	M6x1	90	80	10	14	30	69.5	20	40
	Gx	A4	115	M8x1.25	100	95	10	19	40	69.5	28.5	40
	Gx	AB	66.68	M5x0.8	90	38.15	3	6.35	20.8	69.5	20	40
	Gx	AC	66.68	M5x0.8	90	38.15	3	9.53	20.8	69.5	20	40
	Gx	AD	66.68	M5x0.8	90	38.15	3	9.53	31.8	69.5	20	40
	Gx	AE	98.43	M5x0.8	90	73	10	12.70	37.1	69.5	20	40
	Gx	AF	98.43	M5x0.8	90	73	10	12.70	31.8	69.5	20	40
	Gx	AH	63	M5x0.8	90	40	3	9	23	69.5	20	40
	Gx	AL	100	M6x1	90	80	10	16	40	69.5	20	40
	Gx	AN	70	M5x0.8	90	50	10	14	30	69.5	20	40
	Gx	AP	90	M6x1	90	70	10	19	40	69.5	20	40
	Gx	B1	90	M5x0.8	90	60.01	10	11	23	69.5	20	40
	Gx	B3	95	M6x1	90	50	10	14	30	69.5	20	40
	Gx	B6	63	M4x0.7	90	40	3	9	23	69.5	20	40
	Lx	A2	63	M5x0.8	90	40	3	11	23	85.5	20	30
	Lx	A3	100	M6x1	90	80	10	14	30	85.5	20	30
	Lx	A4	115	M8x1.25	100	95	10	19	40	85.5	28.5	30
	Lx	AB	66.68	M4x0.7	90	38.15	3	6.35	20.8	85.5	20	30
	Lx	AC	66.68	M5x0.8	90	52	10	9.53	20	85.5	20	30
	Lx	AD	66.68	M5x0.8	90	52	10	9.53	31	85.5	20	30
	Lx	AE	98.43	M5x0.8	90	73.03	10	12.70	37.1	85.5	28.5	30
	Lx	AF	98.43	M5x0.8	90	73	10	12.70	31.8	85.5	20	30
	Lx	AH	63	M5x0.8	90	40	10	9	23	85.5		30
Lx	AL	100	M6x1	90	80	10	16	40	85.5	28.5	30	
Lx	AN	70	M5x0.8	90	50	10	14	30	85.5	20	30	
Lx	AP	90	M6x1	90	70	10	19	40	85.5	28.5	30	
HMRB24	Hx	A4	115	M8x1.25	115	95	10	19	50	90.2	24	40
	Hx	AF	98.4	M5x0.8	115	73.03	10	12.70	31.8	90.2	24	40
	Hx	AK	130	M8x1.25	115	110	10	24	40	90.2	24	40
	Hx	AL	100	M6x1	115	80	10	16	40	90.2	24	40
	Hx	AQ	165	M10x1.5	140	130	10	28	60	90.2	35	40
	Hx	AP	90	M6x1	115	70	10	19	40	90.2	24	40
	Mx	A4	115	M8x1.25	115	95.05	10	19	50	110	24	40
	Mx	AF	98.4	M5x0.8	115	73	10	12.70	31.8	110	24	40
	Mx	AK	130	M8x1.25	115	110	10	24	40	110	35	40
	Mx	AL	100	M6x1	115	80	10	16	40	110	24	40
Mx	AP	90	M6x1	115	70	10	19	40	110	35	40	

¹ When ordering with actuator, use order code ⑨ (see Ordering Information) to specify mounted gearhead size, ratio and orientation:
 Gearhead size example: **F** = PS60 **G** = PS90 **H** = PS115 **J** = PV040TA **K** = PV60TA **L** = PV090TA **M** = PV115TA
 Gearhead ratio and mounting orientation: (Replace "x" to specify)
1 = ratio 3:1 **2** = ratio 5:1 **3** = ratio 10:1
² 3:1 ratio not available on "J" PV040TA gearhead

² Use order code ⑩ (see Ordering Information) to specify appropriately sized motor mounting kit.

Motor Mounting Kit Options

Motor Mounting Kits include a coupling housing, coupling, and flange.

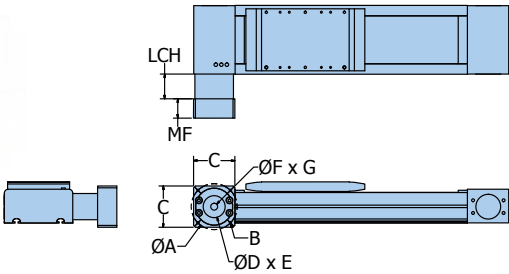
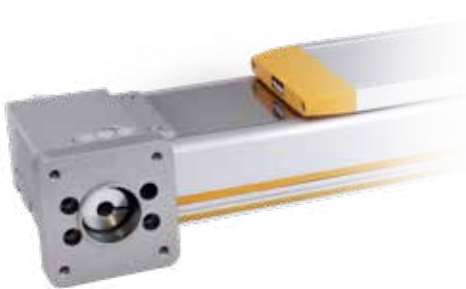

- A = Bolt circle diameter
- B = Screw for bolt circle
- C = Square dimension
- D = Pilot diameter
- E = Pilot depth
- F = Input drive shaft diameter
- G = Input drive shaft length
- LCH = Length coupling housing
- MF = Motor flange

Belt Driven Tables

Actuator Size	Order Code ¹	Dimensions							
		A	B	C	D	E	F	G	MF
HMRB08	A2	63	M5x0.8	60	40	10	11	23	20
	AB	66.68	M4x0.7	60	38.10	10	6.35	20.8	20
	AC	66.68	M5x0.8	60	38.10	10	9.53	20.8	20
	AD	66.68	M5x0.8	60	38.10	15	9.53	31.8	27
	AE	98.43	M6x1	85	73.03	15	12.70	37.1	33
	AF	98.43	M5x0.8	85	73.03	15	12.70	31.8	27
	AG	75	M5x0.8	70	60	10	11	23	20
	AH	63	M5x0.8	60	40	10	9	23	20
	AN	70	M5x0.8	60	50	15	14	30	25
	B0	75	M6x1	70	60	15	14	30	25
	B1	90	M5x0.8	75	60	10	11	23	20
	B2	90	M5x0.8	75	60	15	14	30	25
	B3	95	M6x1	80	50	15	14	30	25
	B6	63	M4x0.7	60	40	10	9	23	20
	B7	70	M5x0.8	60	50	15	8	30	25
B8	70	M5x0.8	60	50	15	12	30	25	
HMRB11	A2	63	M5x0.8	60	40	5	11	23	15
	AB	66.68	M4x0.7	60	38.10	10	6.35	20.8	15
	AC	66.68	M5x0.8	60	38.10	10	9.53	20.8	15
	AD	66.68	M5x0.8	60	38.10	15	9.53	31.8	25
	AE	98.43	M6x1	85	73.03	20	12.70	37.1	33
	AF	98.43	M5x0.8	85	73.03	15	12.70	31.8	27
	AG	75	M5x0.8	70	60	10	11	23	20
	AH	63	M5x0.8	60	40	5	9	23	15
	AL	100	M6x1	92	80	15	16	40	36
	AN	70	M5x0.8	60	50	15	14	30	25
	B0	75	M6x1	70	60	15	14	30	25
	B1	90	M5x0.8	80	60	10	11	23	20
	B2	90	M5x0.8	80	60	15	14	30	25
	B3	95	M6x1	80	50	15	14	30	25
	B7	70	M5x0.8	60	50	15	8	30	25
B8	70	M5x0.8	60	50	15	12	30	25	

(continued from previous page)

HMRB15	A2	63	M5x0.8	84	40	3	11	23	20
	A3	100	M6x1	92	80	5	14	30	20
	A4	115	M8x1.25	100	95	15	19	40	30
	AE	98.43	M6x1	85	73.03	15	12.70	37.1	25
	AF	98.43	M5x0.8	85	73.03	10	12.70	31.8	20
	AL	100	M6x1	92	80	15	16	40	30
	AN	70	M5x0.8	85	50	5	14	30	20
	AP	90	M6x1	84	70	15	19	40	30
	B0	100	M6x1	85	60	5	14	30	20
	B2	90	M5x0.8	85	60	5	14	30	20
HMRB18	A3	100	M6x1	92	80	5	14	30	20
	A4	115	M8x1.25	100	95	15	19	40	30
	AF	98.43	M5x0.8	90	73.03	10	12.70	31.8	20
	AK	130	M8x1.25	115	110	25	24	50	40
	AL	100	M6x1	92	80	15	16	40	30
	AP	90	M6x1	90	70	15	19	40	30
	B0	75	M6x1	90	60	10	14	30	20
	B2	90	M6x1	90	60	10	14	30	20
HMRB24	A4	115	M8x1.25	110	95	5	19	40	20
	AK	130	M8x1.25	115	110	5	24	50	20

¹ When ordering with actuator, use order code $\text{\textcircled{C}}$ to specify appropriately sized motor mounting kit. See Ordering Information.

Coupling Housing LCH Dimensions (For all Gearhead and Motor Mounting Options)

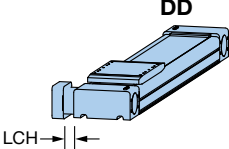
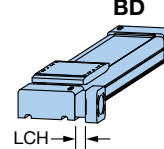
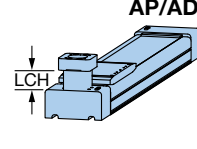
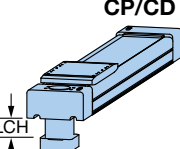
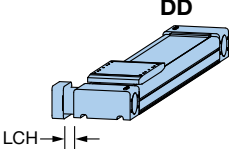
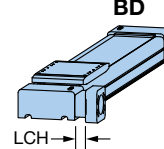
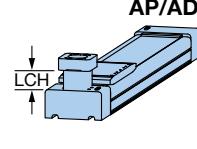
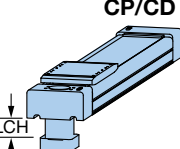
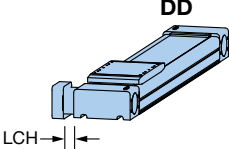
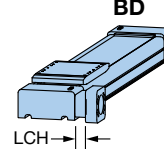
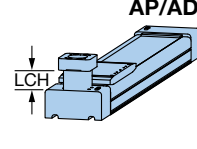
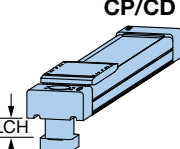
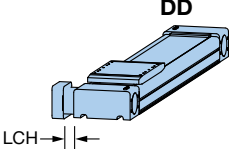
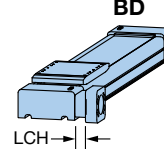
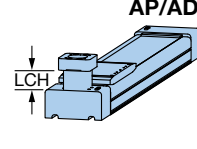
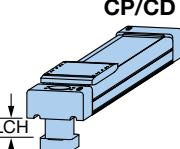
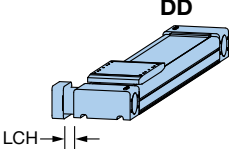
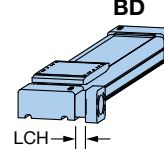
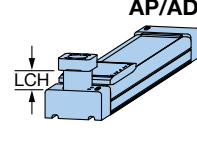
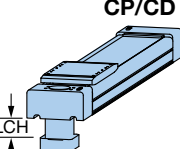
Actuator Size	Order Code	LCH (mm)	DD	BD	AP/AD	CP/CD
HMRB08	BD, DD	13				
	AP, CP, AD, CD	28				
HMRB11	BD, DD	15				
	AP, CP, AD, CD	37				
HMRB15	BD, DD	30				
	AP, CP, AD, CD	54				
HMRB18	BD, DD	42				
	AP, CP, AD, CD	70				
HMRB24	BD, DD	60				
	AP, CP, AD, CD	85				

Mounted Gearhead and Motor Options

Mounted Gearhead and Motor options include a coupling housing, flange, gearhead with coupler, flange and motor

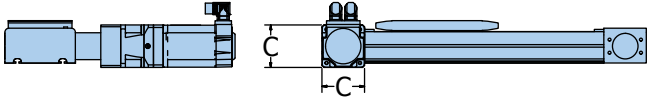
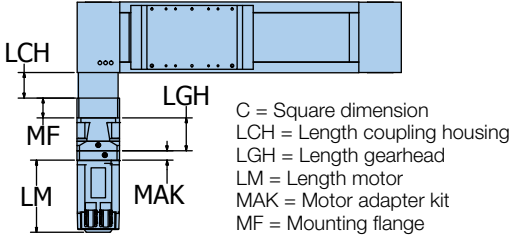

Belt Driven Tables

Actuator Size	Order Code ¹	Order Code ²	Mounted Motor	C	LGH	LM	MAK	MF
HMRB08	Jx	K0	BE233FJ-KPSN	60	48.5	143.2	26	20
	Jx	K1	BE233FJ-KPSN with Brake (CM233FJ-115027)	60	48.5	178	26	20
HMRB11	Fx	K0	BE233FJ-KPSN	60	59.8	143.2	16.5	35
	Fx	K1	BE233FJ-KPSN with Brake (CM233FJ-115027)	60	59.8	178	16.5	35
	Fx	K2	BE344LJ-KPSN	60	59.8	188	22.5	35
	Fx	K3	BE344LJ-KPSB	60	59.8	231	22.5	35
	Fx	K4	PM-FBL04AMK	60	59.8	108.2	16.5	35
	Fx	K5	PM-FBL04AMK2 (w/ Brake)	60	59.8	148.2	16.5	35
	Jx	K0	BE233FJ-KPSN	60	48.5	143.2	26	20
	Jx	K1	BE233FJ-KPSN with Brake (CM233FJ-115027)	60	48.5	178	26	20
	Kx	K0	BE233FJ-KPSN	80	67	143.2	22.5	35
	Kx	K1	BE233FJ-KPSN with Brake (CM233FJ-115027)	80	67	178	22.5	35
	Kx	K2	BE344LJ-KPSN	80	67	188	22.5	35
	Kx	K3	BE344LJ-KPSB	80	67	231	22.5	35
Kx	K4	PM-FBL04AMK	80	67	108.2	22.5	35	
Kx	K5	PM-FBL04AMK2 (w/ Brake)	80	67	148.2	22.5	35	

¹ When ordering with actuator, use order code ⑨ (see Ordering Information) to specify mounted gearhead size, ratio and orientation:
 Gearhead size example: **F** = PS60 **G** = PS90 **H** = PS115 **J** = PV040TA **K** = PV60TA **L** = PV090TA **M** = PV115TA
 Gearhead ratio and mounting orientation: (Replace "x" to specify)

1 = ratio 3:1 **2** = ratio 5:1 **3** = ratio 10:1

^{*} 3:1 ratio not available on "J" PV040TA gearhead

² Use order code ⑩ (see Ordering Information) to specify appropriately sized motor mounting kit.

(continued next page)

(continued from previous page)

Actuator Size	⑨	⑩	Mounted Motor	C	LGH	LM	MAK	MF
	Order Code ¹	Order Code ²						
HMRB15	Fx	K0	BE233FJ-KPSN	85	59.8	143.2	16.5	30
	Fx	K1	BE233FJ-KPSN with Brake (CM233FJ-115027)	85	59.8	178	16.5	30
	Fx	K2	BE344LJ-KPSN	85	59.8	188	22.5	30
	Fx	K3	BE344LJ-KPSB	85	59.8	231	22.5	30
	Fx	K4	PM-FBL04AMK	85	59.8	108.2	16.5	30
	Fx	K5	PM-FBL04AMK2 (w/ Brake)	85	59.8	148.2	16.5	30
	Gx	K2	BE344LJ-KPSN	90	69.5	188	20	42
	Gx	K3	BE344LJ-KPSB	90	69.5	231	20	42
	Gx	K6	PM-FCL10AMK	90	69.5	152.7	20	42
	Gx	K7	PM-FCL10AMK2 (w/ Brake)	90	69.5	193	20	42
	Gx	M0	MPP0923D1E-KPSN	90	69.5	178	20	42
	Gx	M1	MPP0923D1E-KPSB	90	69.5	212.5	20	42
	Gx	M2	MPP1003D1E-KPSN	90	69.5	174.5	28.5	42
	Gx	M3	MPP1003D1E-KPSB	90	69.5	223	28.5	42
	Gx	M4	MPP1003R1E-KPSN	90	69.5	174.5	28.5	42
	Gx	M5	MPP1003R1E-KPSB	90	69.5	223	28.5	42
	Kx	K0	BE233FJ-KPSN	84	67	143.2	22.5	30
	Kx	K1	BE233FJ-KPSN with Brake (CM233FJ-115027)	84	67	178	22.5	30
	Kx	K2	BE344LJ-KPSN	84	67	188	22.5	30
	Kx	K3	BE344LJ-KPSB	84	67	231	22.5	30
	Kx	K4	PM-FBL04AMK	84	67	108.2	22.5	30
	Kx	K5	PM-FBL04AMK2 (w/ Brake)	84	67	148.2	22.5	30
	Lx	K2	BE344LJ-KPSN	92	85.5	188	20	36
	Lx	K3	BE344LJ-KPSB	92	85.5	231	20	36
	Lx	K6	PM-FCL10AMK	92	85.5	152.7	28.5	36
	Lx	K7	PM-FCL10AMK2 (w/ Brake)	92	85.5	193	28.5	36
	Lx	M0	MPP0923D1E-KPSN	92	85.5	178	28.5	36
	Lx	M1	MPP0923D1E-KPSB	92	85.5	212.5	28.5	36
	Lx	M2	MPP1003D1E-KPSN	92	85.5	174.5	28.5	36
	Lx	M3	MPP1003D1E-KPSB	92	85.5	223	28.5	36
Lx	M4	MPP1003R1E-KPSN	92	85.5	174.5	28.5	36	
Lx	M5	MPP1003R1E-KPSB	92	85.5	223	28.5	36	

¹ When ordering with actuator, use order code ⑨ (see Ordering Information) to specify mounted gearhead size, ratio and orientation:
 Gearhead size example: **F** = PS60 **G** = PS90 **H** = PS115 **J** = PV040TA **K** = PV60TA **L** = PV090TA **M** = PV115TA
 Gearhead ratio and mounting orientation: (Replace "x" to specify)

1 = ratio 3:1 **2** = ratio 5:1 **3** = ratio 10:1

^{*} 3:1 ratio not available on "J" PV040TA gearhead

² Use order code ⑩ (see Ordering Information) to specify appropriately sized motor mounting kit.

(continued next page)

Mounted Gearhead and Motor Options

(continued from previous page)

Actuator Size	Order Code ¹	Order Code ²	Mounted Motor	C	LGH	LM	MAK	MF
HMRB18	Gx	K2	BE344LJ-KPSN	100	69.5	188	20	40
	Gx	K3	BE344LJ-KPSB	100	69.5	231	20	40
	Gx	K6	PM-FCL10AMK	100	69.5	152.7	20	40
	Gx	K7	PM-FCL10AMK2 (w/ Brake)	100	69.5	193	20	40
	Gx	M0	MPP0923D1E-KPSN	100	69.5	178	20	40
	Gx	M1	MPP0923D1E-KPSB	100	69.5	212.5	20	40
	Gx	M2	MPP1003D1E-KPSN	100	69.5	174.5	28.5	40
	Gx	M3	MPP1003D1E-KPSB	100	69.5	223	28.5	40
	Gx	M4	MPP1003R1E-KPSN	100	69.5	174.5	28.5	40
	Gx	M5	MPP1003R1E-KPSB	100	69.5	223	28.5	40
	Lx	K2	BE344LJ-KPSN	92	85.5	188	20	30
	Lx	K3	BE344LJ-KPSB	92	85.5	231	20	30
	Lx	K6	PM-FCL10AMK	92	85.5	152.7	28.5	30
	Lx	K7	PM-FCL10AMK2 (w/ Brake)	92	85.5	193	28.5	30
	Lx	M0	MPP0923D1E-KPSN	92	85.5	178	28.5	30
	Lx	M1	MPP0923D1E-KPSB	92	85.5	212.5	28.5	30
	Lx	M2	MPP1003D1E-KPSN	92	85.5	174.5	28.5	30
	Lx	M3	MPP1003D1E-KPSB	92	85.5	223	28.5	30
	Lx	M4	MPP1003R1E-KPSN	92	85.5	174.5	28.5	30
	Lx	M5	MPP1003R1E-KPSB	92	85.5	223	28.5	30
HMRB24	Hx	M6	MPP1154B1E-KPSN	115	90.2	203.2	24	40
	Hx	M7	MPP1154B1E-KPSB	115	90.2	251.7	24	40
	Hx	M8	MPP1154P1E-KPSN	115	90.2	203.2	24	40
	Hx	M9	MPP1154P1E-KPSB	115	90.2	251.7	24	40
	Hx	MA	MPP1424C1E-KPSN	115	90.2	223.7	35	40
	Hx	MB	MPP1424C1E-KPSB	115	90.2	275.3	35	40
	Hx	MC	MPP1424R1E-KPSN	115	90.2	223.7	35	40
	Hx	MD	MPP1424R1E-KPSB	115	90.2	275.3	35	40
	Mx	M6	MPP1154B1E-KPSN	125	110	203.2	35	40
	Mx	M7	MPP1154B1E-KPSB	125	110	251.7	35	40
	Mx	M8	MPP1154P1E-KPSN	125	110	203.2	35	40
	Mx	M9	MPP1154P1E-KPSB	125	110	251.7	35	40

¹ When ordering with actuator, use order code **9** (see Ordering Information) to specify mounted gearhead size, ratio and orientation:
 Gearhead size example: **F** = PS60 **G** = PS90 **H** = PS115 **J** = PV040TA **K** = PV60TA **L** = PV090TA **M** = PV115TA
 Gearhead ratio and mounting orientation: (Replace "x" to specify)

1 = ratio 3:1 **2** = ratio 5:1 **3** = ratio 10:1
 * 3:1 ratio not available on "J" PV040TA gearhead

² Use order code **0** (see Ordering Information) to specify appropriately sized motor mounting kit.

Belt Driven Tables

Limit & Home Sensors

The HMR uses Parker's Global Sensor line, which can be mounted in the longitudinal t-slots running along the actuator body. These sensors mount flush to the extrusion body, minimizing the overall width of the actuator.

Parker's Global Sensors feature short circuit protection, power up pulse protection, and reverse polarity protection.

The sensor cable can be concealed under the yellow T-slot covers which are provided with each unit.

For internally configured sensors, the cables are routed internally and exit and the end cap of the unit through industrially hardened M8 connectors.



In the event internal sensors are configured, they cannot be re-positioned in the field. The pre-set location is configured in the part number model code. Please consult factory for further assistance.

Permanent magnets integrated into the carriage assembly actuate the sensors as the carriage traverses it linear travel.

All actuators pre-configured with a sensor pack, come pre-configured with a 5 meter extension cable, with flying leads.

Common Specifications:

- Electric current drain:** 100 mA (max)
- Switching current:** 10 mA (max)
- Supply voltage:** 10 – 30 VDC
- Switching Frequency:** 1 kHz

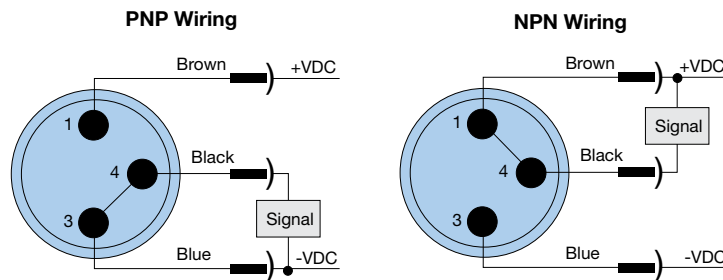

Magnetic LED Cylinder Sensors

Model Number	Function	Logic	Cable
P8SAGPFAX	N.O.	PNP	3 m
P8SAGNFAX		NPN	
P8SAGPCHX		PNP	0.3 m cable with M8 connector*
P8SAGNCHX		NPN	
P8SAGQFAX	N.C.	PNP	3 m
P8SAGMFAX		NPN	
P8SAGQCHX		PNP	0.3 m cable with M8 connector*
P8SAGMCHX		NPN	

* 003-2918-01 is a 5 m extension cable to flying leads for these cables

Limit & Home Sensor Dimensions

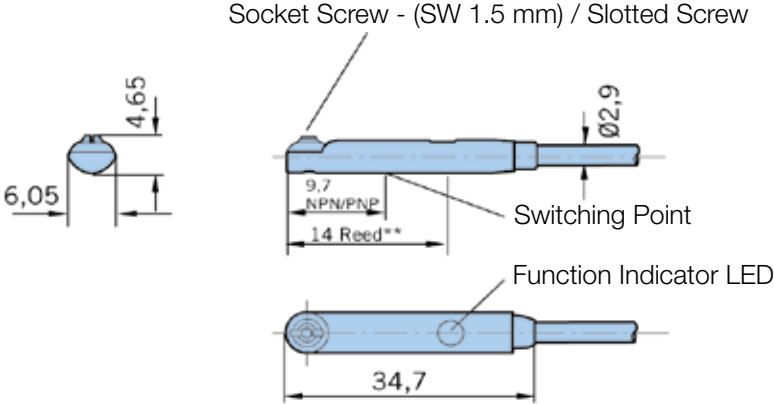

P8S-... cable with flying leads

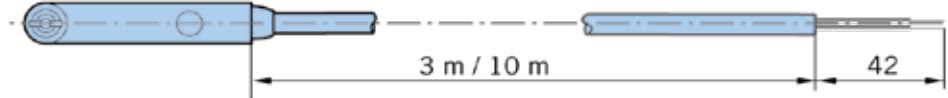

P8S-... cable with M8 rotatable

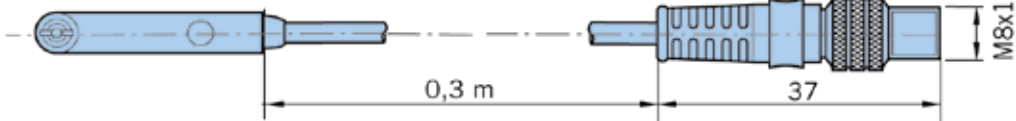

Installation for Magnetic T-Slot Sensors

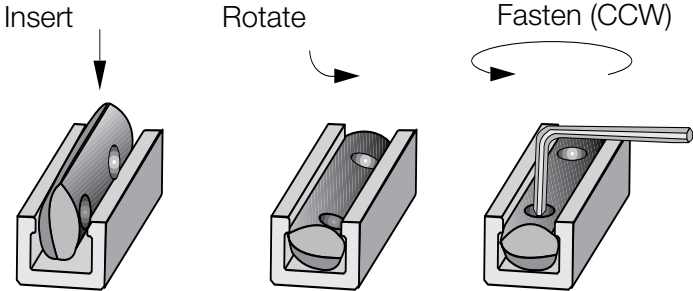

Protective Cover Options

Two Versions Available: Covers can be field retro-fitted if initially configured without covers.

Consult maintenance manual or factory support for assistance in specifying replacement covers and installation procedures.

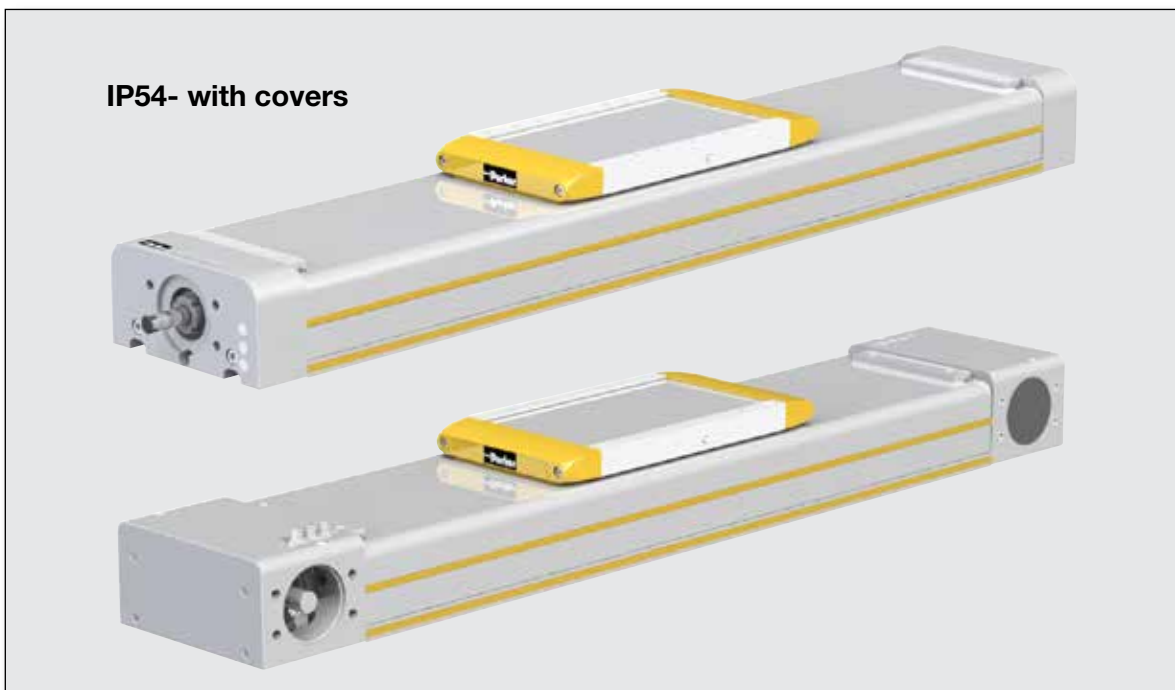
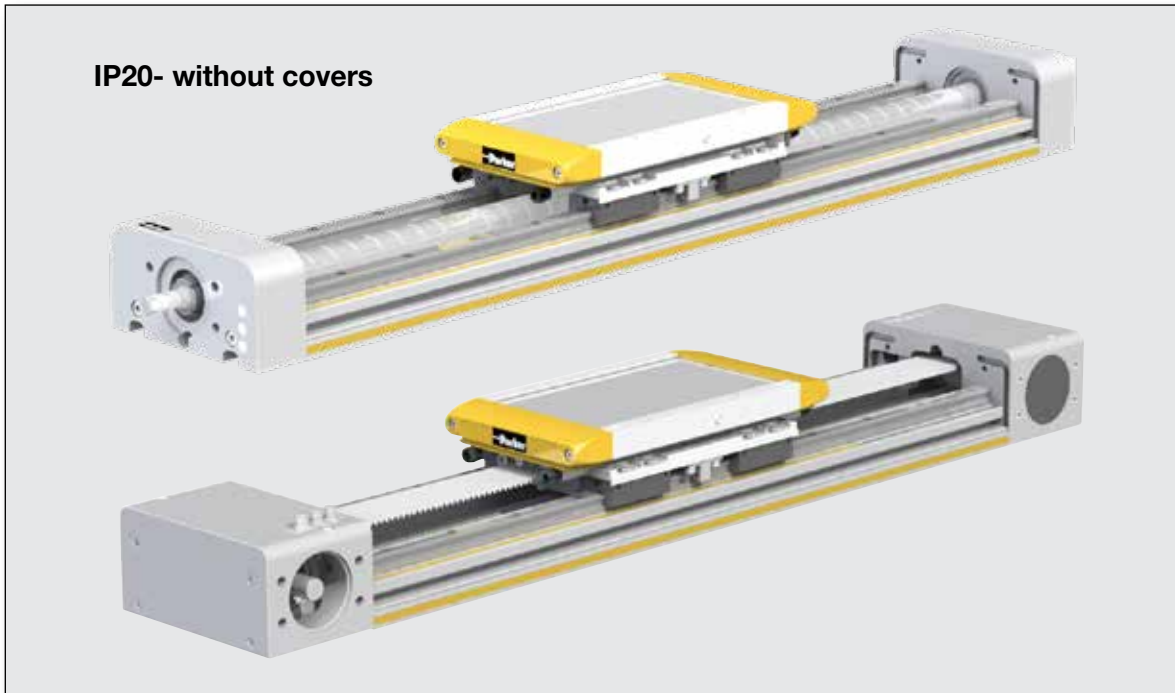

Coupling Housing

Belt Driven Tables

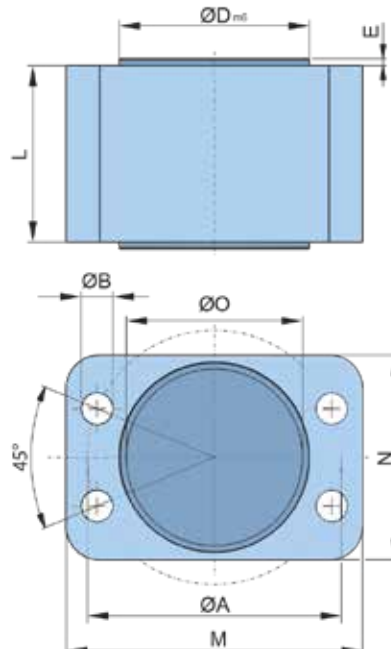

Dimension table - Coupling housing long HMRS / HMRB [mm]

Product size	Ø A	Ø B	Ø D _{m6}	E	Ø O	L	M	N	Order no.
HMRx08 ⁽¹⁾	42	4.5	34	2	30	28	49	37	56568FIL
HMRx11 ⁽¹⁾	51	6.6	39	1	35	37	60	42	56566FIL
HMRx15 ⁽¹⁾	72	9.0	54	2	50	54	84	58	50353FIL
HMRx18 ⁽¹⁾	80	9.0	64	2	60	70	90	68	50655FIL
HMRx24 ⁽¹⁾	95	11.0	80	2	77	85	107	85	56415FIL

⁽¹⁾Suitable for all types of HMRS

⁽¹⁾Suitable for HMRB with motor orientation 000° top (HMRBxxxAP; HMRBxxxAD)

⁽¹⁾Suitable for HMRB with motor orientation 180° bottom and profile version Basic (HMRBxxBCP; HMRBxxBCD; HMRBxxCCP; HMRBxxCCD)

Dimension table - Coupling housing short HMRB [mm]

Product size	Ø A	Ø B	Ø D _{m6}	E	Ø O	L	M	N	Order no.
HMRB08 ⁽¹⁾	42	4.5	34	2	30	13	49	37	56567FIL
HMRB08 ⁽²⁾	42	4.5	34	2	30	17	49	37	56569FIL
HMRB11 ^{(1) (2)}	51	6.6	39	1	35	15	60	42	56565FIL
HMRB15 ^{(1) (2)}	72	9.0	54	2	50	30	84	58	56412FIL
HMRB18 ^{(1) (2)}	80	9.0	64	2	60	42	90	68	56413FIL
HMRB24 ^{(1) (2)}	95	11.0	80	2	77	60	107	85	56414FIL

⁽¹⁾Suitable for HMRB with motor orientation 090° front and 270° rear (HMRBxxxBD; HMRBxxxDD)

⁽²⁾Suitable for HMRB with motor orientation 180° bottom re-inforced profile (HMRBxxRCP; HMRBxxRCD; HMRBxxSCP; HMRBxxSCD)

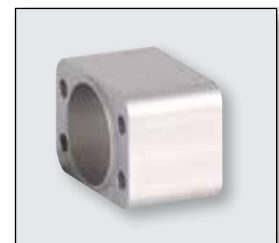

Coupling

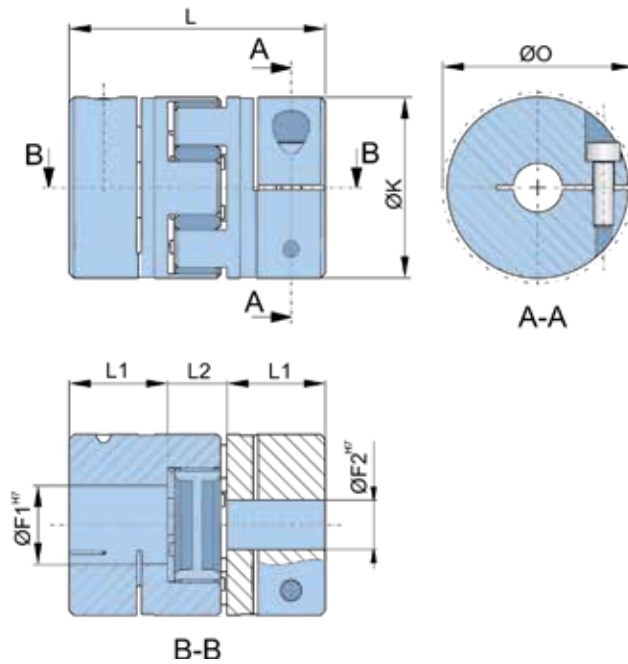

Ball screw

Dimension table - motor coupling HMRS [mm]

Product size	F ₁	F ₂	F	K	L	L ₁	L ₂	Ø O	Order no.
HMRS08	6	9	5 - 12	25	34	11	12	27.5	56562FIL
HMRS11	10	9	6 - 16	30	35	11	13	32.5	13210FIL
HMRS15	12	9	8 - 24	40	66	25	16	58.0	56400FIL
HMRS18	15	14	10 - 28	55	78	30	18	68.0	56402FIL
HMRS24	20	14	14 - 38	65	90	35	20	73.0	56510FIL

Belt

Dimension table - motor coupling HMRB [mm]

Product size	F ₁	F ₂	F	K	L	L ₁	L ₂	Ø O	Order no.
HMRB08	10	9	5 - 12	25	34	11	12	27.5	56563FIL
HMRB11	12	9	6 - 16	30	35	11	13	32.5	56560FIL
HMRB15	15	10	8 - 24	40	66	25	16	58.0	16239FIL
HMRB18	18	14	10 - 28	55	78	30	18	68.0	56411FIL
HMRB24	24	15	14 - 38	65	90	35	20	73.0	16260FIL



Shock Absorbing Bumper

HMR actuators come factory installed with impact protection bumpers. These carriage mounted bumpers can compensate the energy released by unintentional impact and afford some protection against mechanical damage.

Two bumpers (four total) are fitted to each side of the carriage.

Shock absorbers for impact protection

Product size		HMRx08	HMRx11	HMRx15	HMRx18	HMRx24
Shock absorber		TA12-5	TA12-5	TA12-5	TA17-7	TA17-7
Energy absorption	[Nm/stroke]	3.0	3.0	3.0	8.5	8.5

Distance-force and energy-distance characteristic curve (dynamic)
 – frame sizes HMRx08, HMRx11, HMRx15

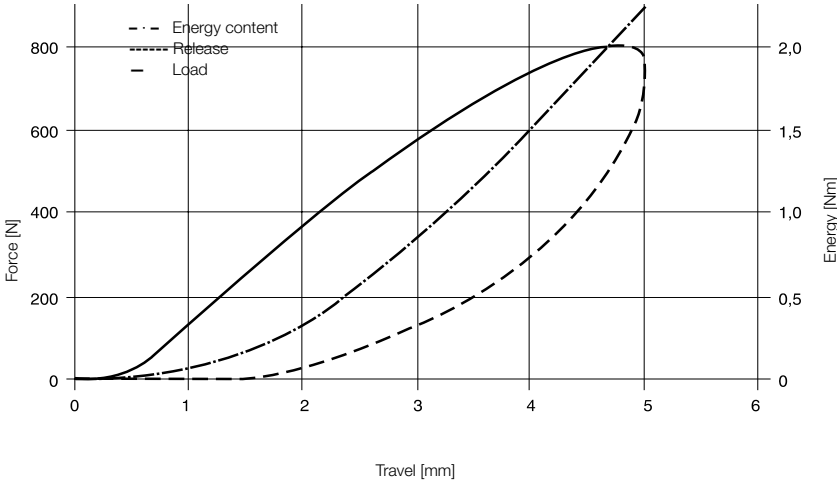

Distance-force and energy-distance characteristic curve (dynamic)
 – frame sizes HMRx18, HMRx24

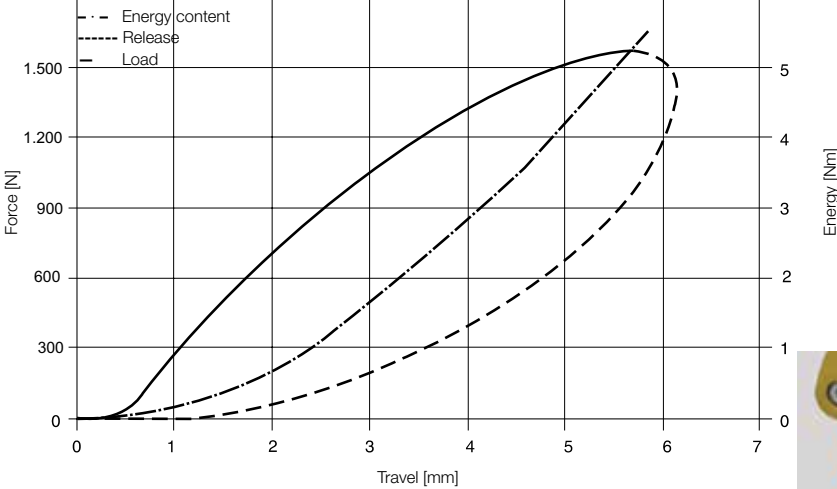

Dowel Sleeves

Dowel sleeves can be used to provide pinning functionality between the carriage mounting surface and the payload. These sleeves have a tightly toleranced outer diameter to accurately locate between the bore in the carriage and the end effector, but have a hollow center granting access to the threaded hole in the carriage underneath the pin bore. This means that these dowel pin bore can additionally function as a threaded connection to the carriage. See Dimensions for carriage mounting detail.

7mm Outer Diameter Dowel Sleeve

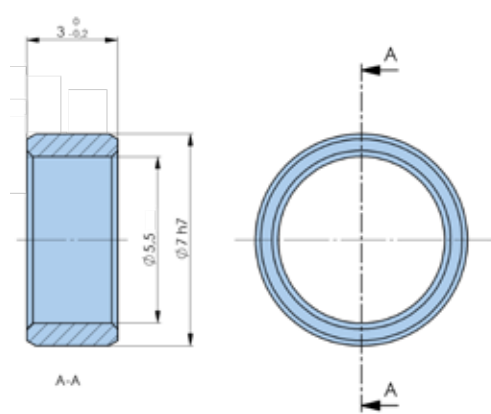

9mm Outer Diameter Dowel Sleeve

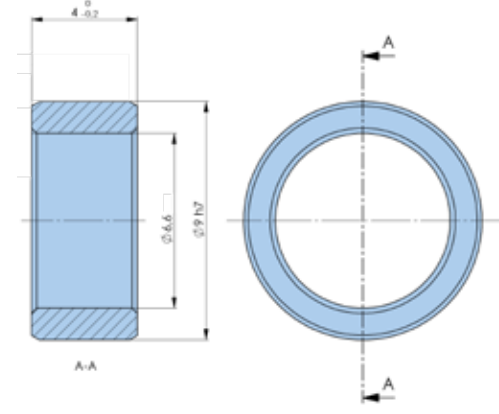

12mm Outer Diameter Dowel Sleeve

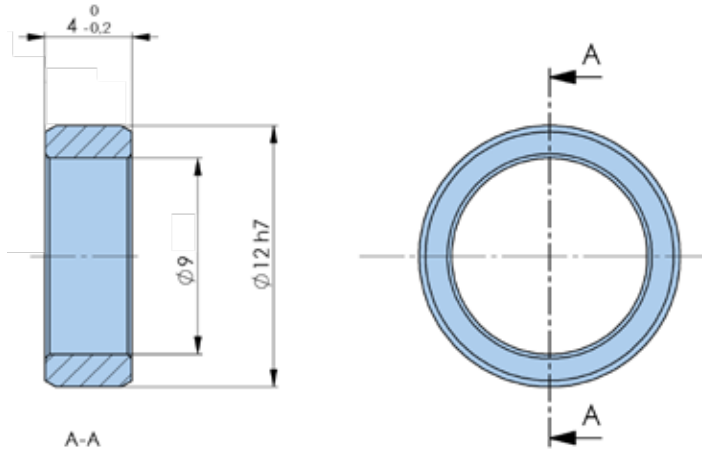

Part Number	Description	HMR Frame Size
56455FIL	7mm Dowel Sleeve- 4 Pack	HMRx08, HMRx11, HMRx15
56456FIL	7mm Dowel Sleeve- 10 Pack	HMRx08, HMRx11, HMRx15
56457FIL	9mm Dowel Sleeve- 4 Pack	HMRx18
56458FIL	9mm Dowel Sleeve- 10 Pack	HMRx18
56459FIL	12mm Dowel Sleeve- 4 Pack	HMR24

Actuator Mounting

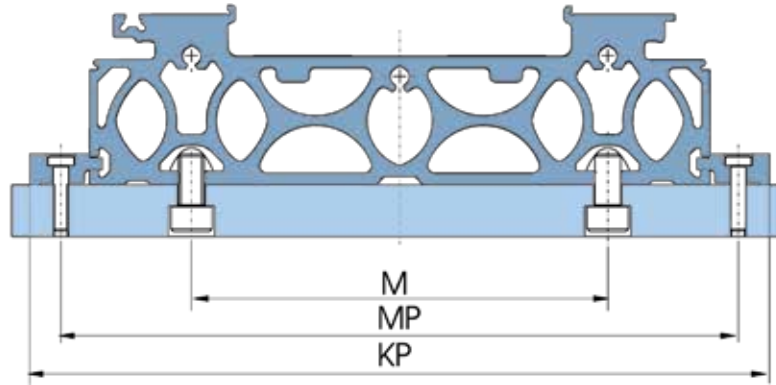

Belt Driven Tables

Dimension table - Product width HMR [mm]

Product size	Toe-clamp mounting (mm)		T-nut mounting (mm)
	MP	KP	M
HMRx08	97	115	50
HMRx11	122	140	70
HMRx15	170	190	96
HMRx18	202	226	116
HMRx24	262	286	161

Holding force per mounting set [N]

Product size	In longitudinal direction of the actuator*	Toe-clamp			In longitudinal direction of the actuator*	T-nut		
		Screw 2x	Tightening torque [Nm]	Max. load per screw		Screw 1x	Tightening torque [Nm]	Max. load per screw
HMRx08	800	M4	3	900	1,000	M5	6	1,200
HMRx11	800	M4	3	900	1,000	M5	6	1,200
HMRx15	1,820	M5	6	1,200	1,600	M6	10	1,700
HMRx18	2,610	M6	10	1,700	2,700	M8	20	3,400
HMRx24	2,610	M6	10	1,700	3,200	M10	40	5,500

*A friction factor of 0.15 between profile and mounting surface was taken as a basis for the calculation of the forces that can be transmitted in longitudinal direction, Screw property class 8.8.

Actuator Mounting

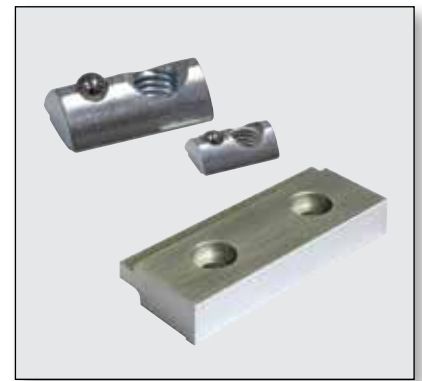
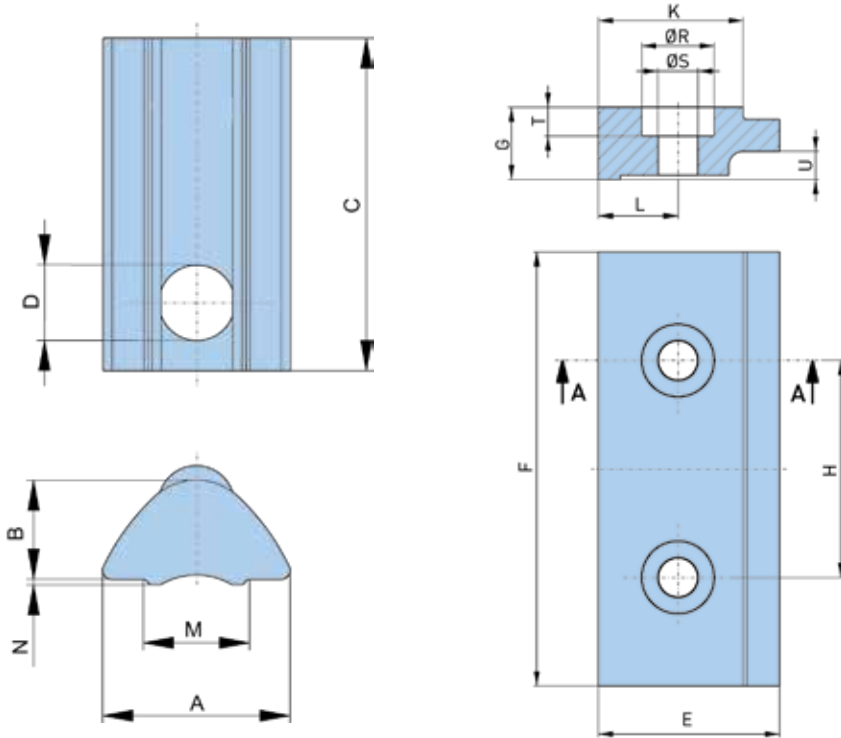

Dimension table - T-nut mounting HMR [mm]

Product size	A	B	C	Ø D	M	N	Order no. *
HMRx08	8.0	4.0	11.5	M5	5.0	0.5	56351FIL
HMRx11	8.0	4.0	11.5	M5	5.0	0.5	56351FIL
HMRx15	10.5	6.4	22.5	M6	6.4	0.6	56352FIL
HMRx18	13.5	6.7	22.5	M8	8.5	1.0	56353FIL
HMRx24	16.5	8.9	28.5	M10	10.5	1.0	56354FIL

* Packing unit 10 pc

Dimension table - Toe-clamp mounting HMR [mm]

Product size	E	F	G	H	K	L	Ø R	Ø S	T	U	Order no. *
HMRx08	18.0	40.0	7.5	20.0	15.0	9.0	0.0	4.5	0.0	2.8	56363FIL
HMRx11	18.0	40.0	7.5	20.0	15.0	9.0	0.0	4.5	0.0	2.8	56363FIL
HMRx15	25.0	60.0	10.0	30.0	20.0	10.0	10.0	5.5	4.0	3.9	56355FIL
HMRx18	28.0	80.0	12.0	40.0	23.0	12.0	11.0	6.6	4.7	5.9	56356FIL
HMRx24	28.0	80.0	12.0	40.0	23.0	12.0	11.0	6.6	4.7	5.9	56356FIL

* Packing unit 1 pair (2 toe-clamps) and associated hardware

ORDERING INFORMATION

HMRB

Select an order code from each of the numbered fields to create a complete HMR belt-driven model order number. Include hyphens and non-selective characters as shown in example below.

			①	②	③	④	⑤	⑥	⑦	⑧	⑨	⑩
Order Number Example:	HMR	B	15	B	BD	0	-	1000	-	A	B	1 0 0 F1 A7

① Frame Size (Profile Width)

8	85 mm
11	110 mm
15	150 mm
18	180 mm
24	240 mm

② Actuator Design (see Dimensions for further detail)

B	Basic Profile with Ball Bearing Guide, No Outer Cover
C	Basic Profile with Ball Bearing Guide, IP54 with Outer Cover
R**	Reinforced Profile with Ball Bearing Guide, No Outer Cover
S**	Reinforced Profile with Ball Bearing Guide, IP54 with Outer Cover

③ Motor Mounting Position and Drive Shaft Design (see Options & Accessories for further detail)

BD	90° Front with Double Plain Shaft
DD	270° Back with Double Plain Shaft
AP**	0° Up with Single Plain Shaft
CP**	180° Down with Single Plain Shaft
AD**	0° Up with Double Plain Shaft
CD**	180° Down with Double Plain Shaft

④ Carriage Design

0	Standard
1	Tandem
2	Bi-parting (Not available with ③ BD and DD options)

⑤ Order Stroke

xxxx 4 digit input in mm (see max stroke by frame size in Specifications)

NOTE: If travel is less than 75mm either Home or Limit Sensors can be used, not both. If travel is less than 20mm, only a Home Sensor can be used.

⑥ Home Sensor* (one sensor)

0	No home sensor
A**	PNP, 3 Wire, N.O., Internal Mounting
K**	NPN, 3 Wire, N.O., Internal Mounting
C	PNP, 3 Wire, N.O., M8 Plug, 0.3 m Cable, External Mounting (P8S-GPCHX)
M	NPN, 3 Wire, N.O., M8 Plug, 0.3 m Cable, External Mounting (P8S-GNCHX)

*P/N 003-2918-01, 5 M extension cable included
***If internal switches are selected they cannot be manually re-positioned in the field.**
****Indicates longer lead time option**

⑦ Limit Sensor* (two sensors)

0	No home sensor
B**	PNP, 3 Wire, N.C., Internal Mounting
L**	NPN, 3 Wire, N.C., Internal Mounting
D	PNP, 3 Wire, N.C., M8 Plug, 0.3 m Cable, External Mounting (P8S-GQCHX)
N	NPN, 3 Wire, N.C., M8 Plug, 0.3 m Cable, External Mounting (P8S-GMCHX)

*P/N 003-2918-01, 5 M extension cable included
***If internal switches are selected they cannot be manually re-positioned in the field.**

⑧ Limit/Home Sensor Position*

0	No Home Sensor
1	10 mm
2	20 mm
3	30 mm
4	40 mm
5	50 mm
6	60 mm
7	70 mm
8	80 mm
9	90 mm
A	100 mm
B	110 mm
C	120 mm
D	130 mm
E	140 mm
F	150 mm
G	160 mm
H	170 mm
J	180 mm
K	190 mm
L	200 mm

*If limit and home sensors selected, this is the distance that limit sensors are positioned from both ends, home sensor positioned 50mm from limit sensor at drive end. If only home sensor selected, it is positioned this distance from the drive end.

⑨ Mounted Gearhead

see Options & Accessories for frame size availability and dimensions)

⑩ Gearhead and Motor Mounting Kits

Gearhead Mounting Kit

(see Options & Accessories for availability and dimensions)

Motor Mounting Kit (Including Flange and Coupling For Direct Drive Motor or Flange on Mounted Gearhead)

(see Options & Accessories for availability and dimensions)

Mounted Gearhead and Motor

(see Options & Accessories for availability and dimensions)

OSPE..BHD Belt-Driven Actuators

High-Speed, Long Travel, Heavy Duty Applications

- High dynamic for precision positioning
- High thrust capacity
- High payload capacity
- High speed operation
- Easy installation
- Ideal in multi axis applications



Features

- Integrated ball bearing guide or roller guide
- Clamp drive shaft design for compact and backlash free gearhead and motor mounting
- Tandem carriage with second carriage for higher load capabilities
- Long available strokes
- Complete motor and drive packages
- Bi-parting carriages and special options on request
- Ambient temperature range -30°C to +80°C
- IP 54 Rating

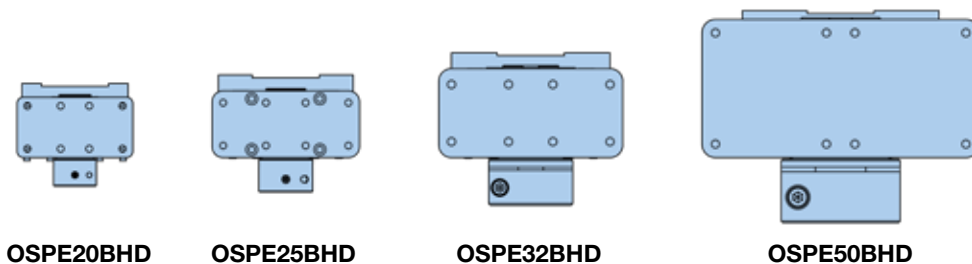

	OSPE20BHD	OSPE25BHD	OSPE32BHD	OSPE50BHD
Maximum Travel (mm)	5,760	5,700	5,600	5,500
Maximum Payload F_z (N)	1,600	3,000	10,000	15,000
Maximum Acceleration (m/sec ²)	50	50	50	50

The OSPE..BHD is the highest capacity belt-driven actuator in the OSPE family. The integrated ball bearing guide or optional roller guide are proven in thousands of industrial machines requiring

robustness, dynamic precision and extraordinary performance with an aesthetically pleasing design.

The compact design allows integration of the OSPE..BHD in any

machine layout, providing very little space, without sacrificing payload or thrust capacity.

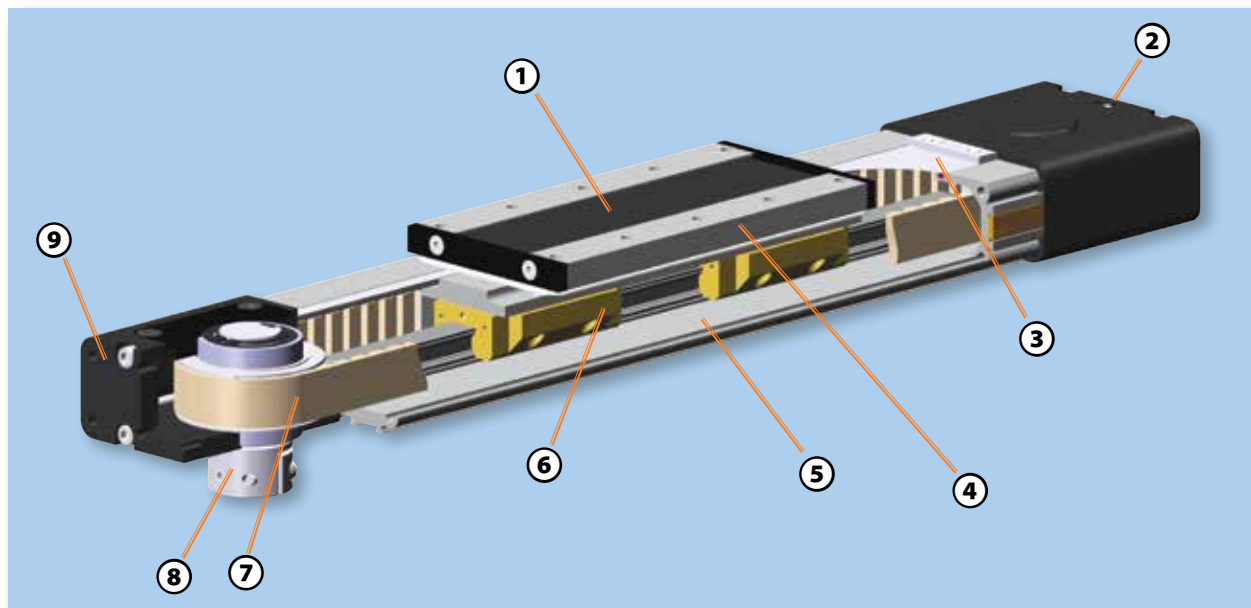

- ① **Carriage**
Low profile, high strength aluminum carriage with threaded holes for ease of mounting
- ② **Belt tensioning station**
Easy access for belt tension without removing the payload
- ③ **Corrosion resistant steel sealing band**
Magnetically fastened to the actuator body and provides sealing to IP54
- ④ **Lubrication access port**
Easy access maintenance allows for single point lubrication of bearing trucks at any point along travel
- ⑤ **Slotted profile**
With dovetail grooves for strength, actuator mounting, and mounting of sensor and other accessories
- ⑥ **Integrated ball bearing truck**
For high performance, high payload and moment load demands. (Optional roller wheels available.)
- ⑦ **Steel reinforced timing belt**
High thrust force transmission and long life
- ⑧ **Clamp shaft**
Optimal, zero-backlash coupling for gearhead and motor
- ⑨ **End housing mounting**
Threaded mounting holes allow for a multitude of mounting options

Integrated Bearing Design

Ball bearing - with a high-precision, hardened-steel rail and calibrated bearing trucks for high load capabilities
 Roller bearing - with an aluminum grounded and calibrated steel track and needle bearing wheels for high-speed operation up to 10 m/s.



Drive Shaft Options

Clamp shaft (for zero-backlash coupling), plain shaft (for dual axis linking), clamp and plain shaft (for master unit to connect link shaft on plain shaft), and hollow shaft (for compact gearhead mounting)

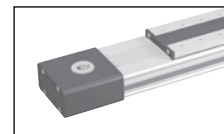

Carriage Options

Standard carriage, tandem carriage — for higher load capabilities, or bi-parting carriage — for opposing synchronized movements



Actuator Mounting Options

End cap mounting — allows the actuator to be anchored by the end caps
 Profile mounts — support long travel actuators or for direct mounting

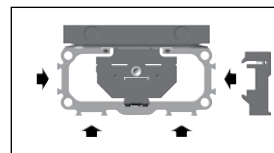

Multi-axis Systems

A wide range of adapter plates and intermediate drive shafts simplifies engineering and installation. Please consult factory for your individual system design.

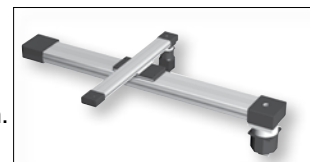

Options and Accessories

Information on all OSPE..BHD Series options is detailed in Options & Accessories. Simply select all the options needed to solve your application requirements, then order with the actuator using convenient order codes (see Ordering Information). To order an option separately as an upgrade to an existing system or as a replacement part, use the individual option part numbers provided.

SPECIFICATIONS

Parker Origa System Plus (OSPE) Series electric motor-driven actuator systems are field-proven worldwide. OSPE Actuator systems are completely modular to accommodate a broad range of application installation and performance requirements. Compact size, maximum configurability and the flexibility to select the right drive train technology for high speed and/ or precise positioning applications makes the OSPE easy to integrate into any machine layout simply and neatly.



Actuator Size			OSPE20BHD	OSPE25BHD		OSPE32BHD		OSPE50BHD	
Integrated Guide Rail ⁽¹⁾			B	B	R	B	R	B	R
Travel Distance per Revolution	S_{lin}	mm	125	180	180	240	240	350	350
Pulley Diameter		mm	39.79	57.30	57.30	76.39	76.39	111.41	111.41
Linear Speed (Max)	v_{max}	m/s	3	5	10	5	10	5	10
Acceleration (Max)	a_{max}	m/s ²	50	50	40	50	40	50	40
Repeatability (unidirectional)		μm	± 50	± 50	± 50	± 50	± 50	± 50	± 50
Order Stroke (Max) ⁽²⁾		mm	5,760	5,700	5,700	5,600	5,600	5,500	5,500
Thrust Force (Max)	F_{Amax}	N	550	1,070	1,070	1,870	1,870	3,120	3,120
		lbs	124	241	241	420	420	701	701
Torque on Drive Shaft (Max)	M_{Amax}	Nm	12	32	32	74	74	177	177
		in-lb	102	282	282	652	652	1,567	1,567
Torque ⁽³⁾ — RMS No Load	M_0	Nm	0.9	1.4	1.4	2.5	2.5	4.2	4.2
		in-lb	8	12	12	22	22	37	37
Torque ⁽³⁾ — Peak No Load	M_0	Nm	1.1	1.9	1.9	3.2	3.2	6.0	6.0
		in-lb	10	17	17	28	28	53	53
Load ⁽⁴⁾ (Max)	F_Y	N	1,600	2,000	986	5,000	1,348	12,000	3,704
		lbs	360	450	222	1,124	303	2,698	833
	F_Z	N	1,600	3,000	986	10,000	1,348	15,000	3,704
		lbs	360	674	222	2,248	303	3,372	833
Bending Moment Load ⁽⁴⁾ (Max)	M_X	Nm	21	50	11	120	19	180	87
		in-lb	186	443	97	1,062	168	1,593	770
	M_Y	Nm	150	500	64	1,000	115	1,800	365
		in-lb	1,328	4,425	566	8,851	1,018	15,931	3,231
M_Z	Nm	150	500	64	1,400	115	2,500	365	
	in-lb	1,328	4,425	566	12,391	1,018	22,127	3,231	
Inertia									
@ Zero Stroke	J_0	kgmm ²	280	1,229	984	3,945	3,498	25,678	19,690
Per Meter of Stroke	J_{OS}	kgmm ² /m	41	227	227	496	496	1,738	1,738
Per 1 kg Moved Mass	J_m	kgmm ² /kg	413	821	821	1,459	1,459	3,103	3,103
Weight									
@ Zero Stroke	m_0	kg	2.0	2.8	2.8	6.2	5.8	18.2	17.9
Per Meter of Stroke	m_{OS}	kg/m	4.0	4.5	4.3	7.8	6.7	17.0	15.2
Carriage	m_C	kg	0.8	1.5	1.0	2.6	1.9	7.8	4.7
Ambient Temperature Range		°C	-30 to +80						
IP Rating)			IP 54						

⁽¹⁾ B = Ball Bearing Guide Rail; R = Roller Guide

⁽²⁾ Longer, extended order strokes on request OSPE20BHD = 6000 mm; OSPE25BHD = 9400 mm; OSPE32BHD = 9200 mm

⁽³⁾ For tandem and bi-parting options double the values listed.

⁽⁴⁾ Load and bending moment based on 8000 km performance

Available Thrust Force by Speed and Stroke

Belt Driven Tables

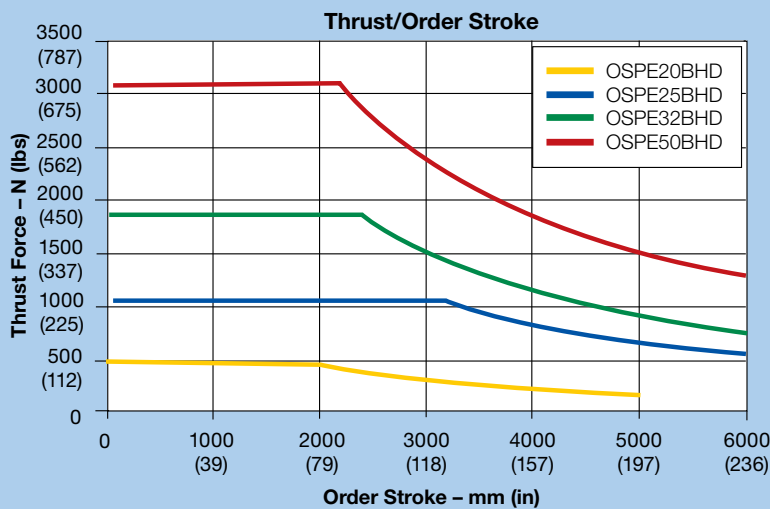
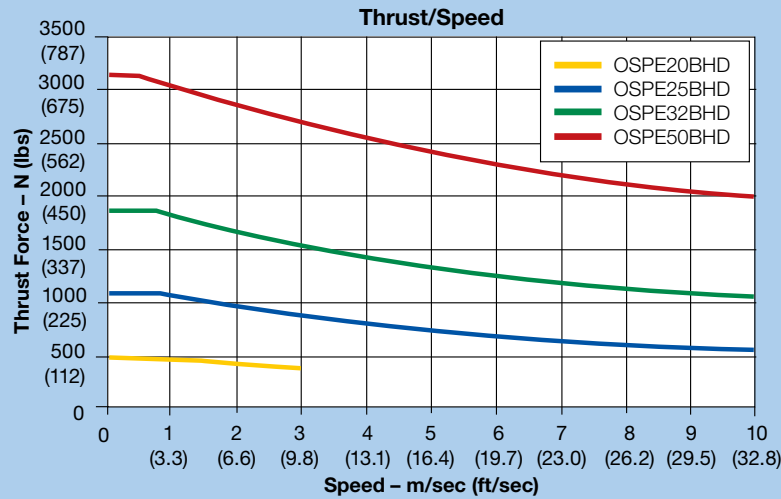

Calculating Load Factors - Combined Normal and Moment Load

The sum of combined loads (static and dynamic) must not exceed "1" at any time as shown in the formula below:

$$\frac{F_z}{F_z(\max)} + \frac{M_x}{M_x(\max)} + \frac{M_y}{M_y(\max)} + \frac{M_z}{M_z(\max)} \leq 1$$

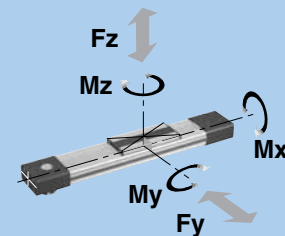

$M = F \times l$ (Nm)
 $M_x = M_{x \text{ static}} + M_{x \text{ dynamic}}$
 $M_y = M_{y \text{ static}} + M_{y \text{ dynamic}}$
 $M_z = M_{z \text{ static}} + M_{z \text{ dynamic}}$

Maximum Permissible Unsupported Length — Determining end cap and profile mounting placement

OSPE..BHD Series actuators need to be mounted onto a solid machine base or frame structure using appropriately positioned end cap and profile mounts. This ensures that the actuator will not undergo excessive deflection based on the application's load and length requirements.

The greater the load and/or the longer the unsupported length between mounts, the more the actuator is susceptible to deflection. Deflection is also dependent on the carriage orientation (F_z for top oriented carriage or F_y for a side mounted carriage).

Standard or Tandem Carriage

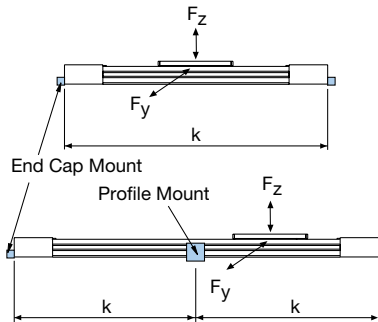

Bi-Parting Carriage

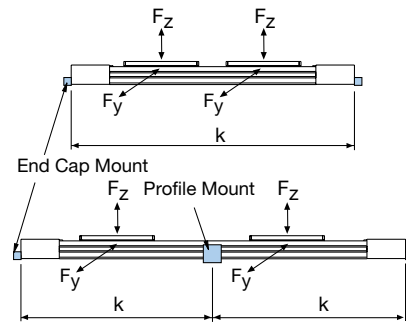

To determine correct end cap and profile mount placement, please follow the steps shown in the example below.

Use the deflection graphs on the next page to insure that the load will not exceed the maximum allowed deflection.

Example:

A horizontal application uses an OSPE32BHD with a top oriented ball bearing carriage. The maximum load on the carriage is 30 kg and the order stroke is 2,400 mm (see previous section to calculate order stroke).

Therefore, the overall length of the actuator will be approximately 3,000 mm:

$$2,400 \text{ mm} + 2 \times \text{Dim "X" (262 mm)} = 2,924 \text{ mm}$$

- 1) Use the Fz graph for a top loaded ball bearing carriage (shown at right)
- 2) Calculate the Load "F" in Newtons based on the 30 kg application load requirement:

$$30 \text{ kg} \times 9.81 \text{ kg/ms}^2 = 294.3 \text{ N}$$

- 3) Draw a line from 294.3 N on the Y-axis to the OSPE32BHD curve, then down to the X-axis.
- 4) The value of "k" is approximately 750 mm.
- 5) Since the overall length (3000 mm) is greater than this value "k", the actuator will require additional fixture points— two end cap mounts and three sets of profile mounts — equally spaced to create a distance "k" of 750 mm in between.
- 6) Maximum deflection of the actuator with this mounting configuration will be less than 0.075 mm:

$$0.01\% \text{ of } 750 \text{ mm} = 0.075 \text{ mm}$$

Ball Bearing Carriage Load-Distance

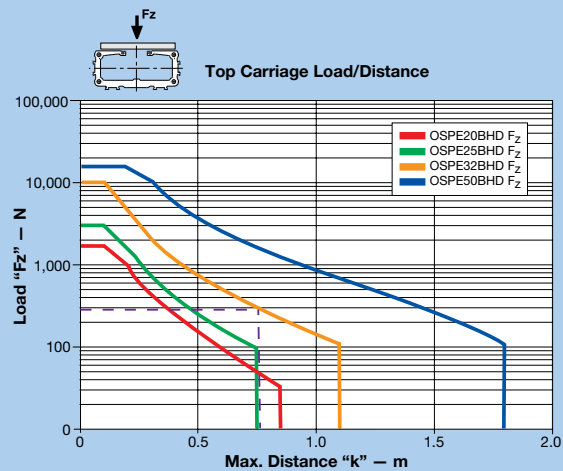

To further reduce deflection:

If the application requires less deflection, then simply reduce the distance "k" appropriately. In this example, for instance, the application must not exceed 0.05 mm. Therefore, "k" must also be 500 mm.

To achieve this reduced maximum deflection, the actuator will require seven fixture points — two end cap mounts and five pairs of profile mounts — equally spaced with a distance "k" of 500 mm in between.

Maximum Permissible Unsupported Length

Determining end cap and profile mounting placement

Use the appropriate deflection graph to ensure that the application load does not exceed the deflection curve. Supporting the actuator within the recommended maximum distance “k” will ensure that the installation will have a maximum deflection equal to 0.01% of distance “k.”

To further reduce deflection, simply reduce the distance between end cap and profile mounts as described in the example on the previous page.

Ball Bearing Carriage Load-Distance

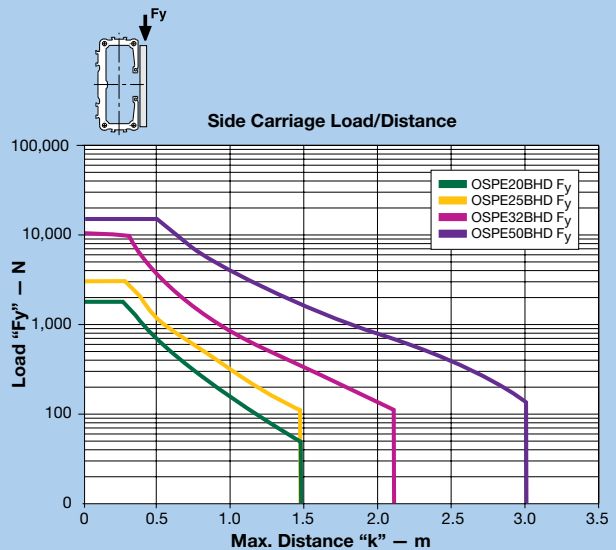
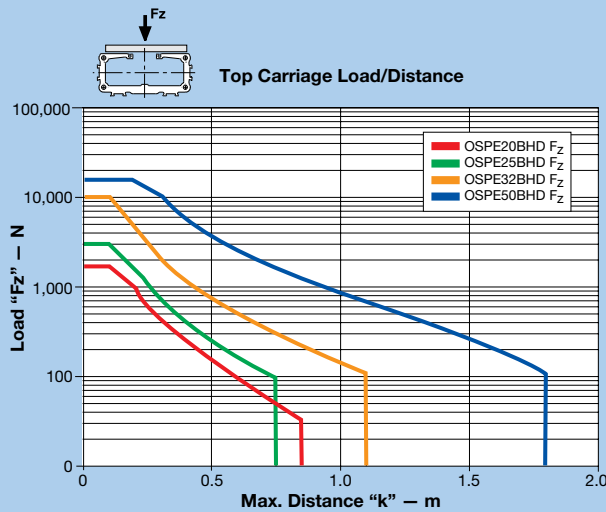

Roller Bearing Carriage Load-Distance

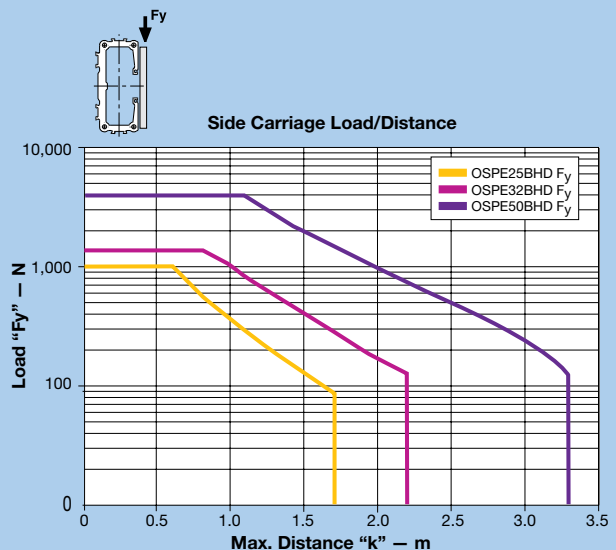
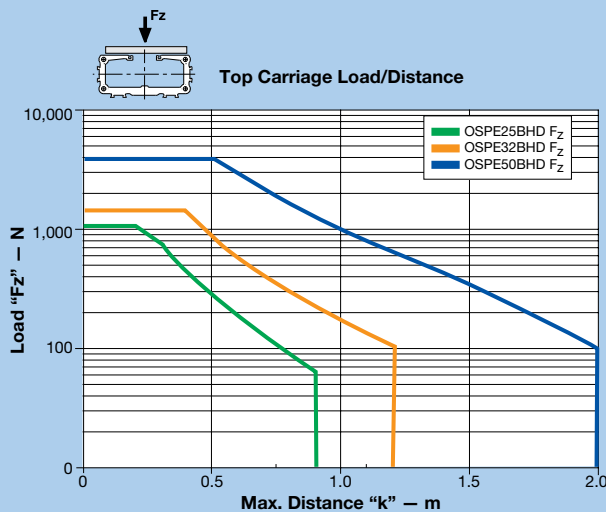



Standard Carriage

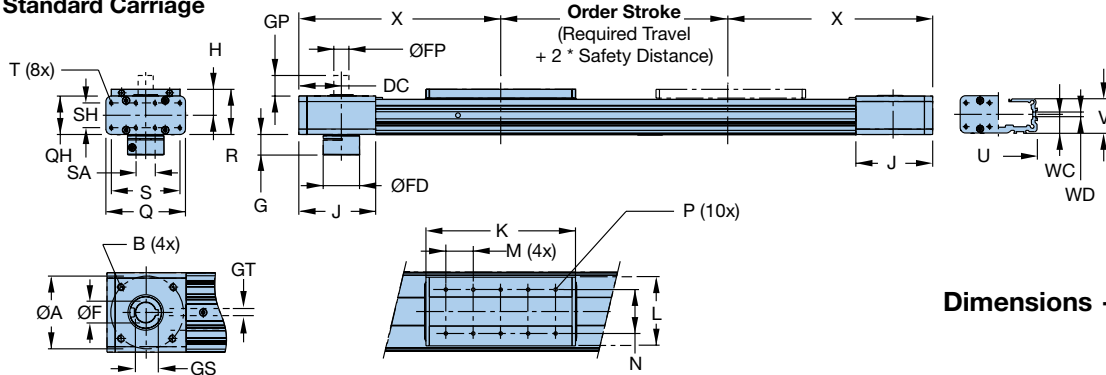

Dimensions – mm

Tandem Carriage

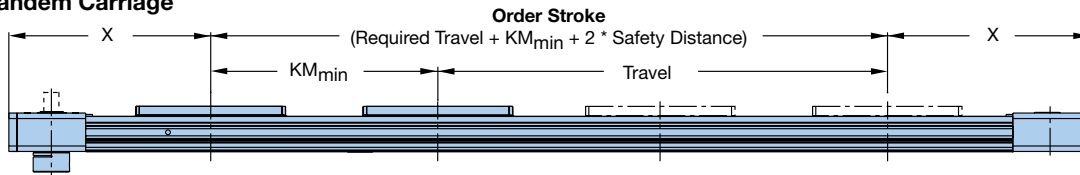

Bi-Parting Carriage

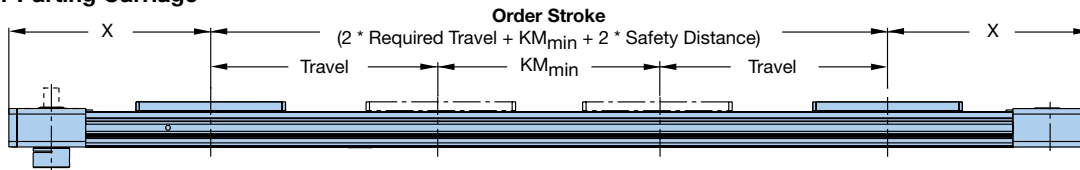

Actuator Size	A	B	DC	F	FD	FP	G	GP	GS	GT
OSPE20BHD	65.7	M6x8	42.5	12 ^{H7}	27	12 _{h7}	18.0	25	13.8	4
OSPE25BHD	82.0	M8x8	49.0	16 ^{H7}	34	16 _{h7}	21.7	30	18.3	5
OSPE32BHD	106.0	M10x12	62.0	22 ^{H7}	53	22 _{h7}	30.0	30	24.8	6
OSPE50BHD	144.0	M12x19	79.5	32 ^{H7}	75	32 _{h7}	41.0	35	35.3	10

* For OSPE50BHD with roller guide: Dimension K = 263

Actuator Size	H	J	K	L	M	N	P	Q	QH
OSPE20BHD	27.6	76.5	155	67	30	51	M5x8	73	38
OSPE25BHD	31.0	88.0	178	85	40	64	M6x8	93	42
OSPE32BHD	38.0	112.0	218	100	40	64	M6x10	116	56
OSPE50BHD	49.0	147.0	288*	124	60	90	M6x10	175	87

Actuator Size	R	S	SA	SH	T	U	V	WC	WD	X
OSPE20BHD	49.0	60	18	27	M5x8.5	73	36.0	21.1	10.4	185
OSPE25BHD	52.5	79	25	27	M5x10	92	39.5	21.5	10.4	218
OSPE32BHD	66.5	100	28	36	M6x12	116	51.7	28.5	10.4	262
OSPE50BHD	92.5	158	18	70	M6x12	164	77.0	43.0	10.4	347

Order Stroke Dimensional Requirements

Actuator Size	KM _{min}	KM _{rec}
OSPE20BHD	180	220
OSPE25BHD	210	250
OSPE32BHD	250	300
OSPE50BHD	354	400

KM_{min} is the minimum distance between two carriages possible.
KM_{rec} is the recommended distance between two carriages for optimal performance.

Order Stroke Safety Distance:

The mechanical end position should not be used as a mechanical end stop, thus an additional **Safety Distance** at both ends of travel must be incorporated into the Order Stroke. The safety distance for servo-driven systems is equivalent to the travel distance per one revolution of the drive shaft. AC motor-driven systems with VFDs require a larger safety distance than servo systems. For further information and design assistance, please consult factory.

OPTIONS & ACCESSORIES

OSPE..BHD Belt-Driven Actuators Gearhead Mounting Kit Options

Gearhead Mounting Kits include a coupling housing and flange

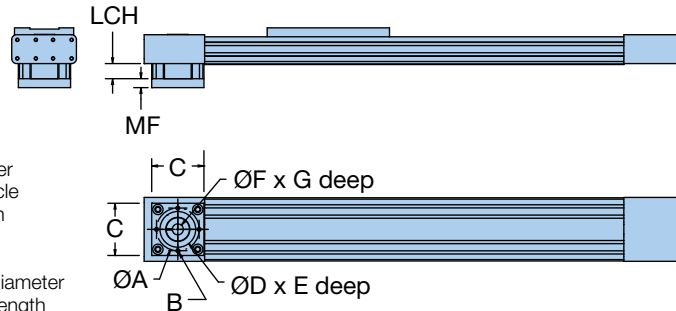

- A = Bolt circle diameter
- B = Screw for bolt circle
- C = Square dimension
- D = Pilot diameter
- E = Pilot depth
- F = Input drive shaft diameter
- G = Input drive shaft length
- LCH = Length coupling housing
- MF = Mounting flange

Belt Driven Tables

OSPE..BHD with Gearhead Mounting Kit

Actuator Size	Order Code ⑥ ¹	Order Code ⑨ ²	Dimensions — mm								
			A	B	C	D	E	F	G	LCH	MF
OSPE20BHD	02, 03, 04 or 05	C0	44	M4	60	35	4.0	12	25	19	9.0
	0A, 0B	C1	62	M5	75	52	6.0	16	36	79	18.5
OSPE25BHD	02, 03, 04 or 05	C1	62	M5	76	52	6.0	16	36	22	13.0
OSPE32BHD	02, 03, 04 or 05	C2	80	M6	98	68	6.0	22	46	30	14.0
OSPE50BHD	02, 03, 04 or 05	C3	108	M8	130	90	6.5	32	70	41	18.0

¹ When ordering with actuator, use order code ⑥ to specify drive shaft orientation and order code ⑨ to specify appropriately sized gearhead mounting kit. See Ordering Information.

■ Blue order codes indicate rapid shipment availability

Mounted Gearhead and Motor Options



Mounted Gearhead and Motor options include a coupling housing, flange, gearhead with coupler, flange and motor

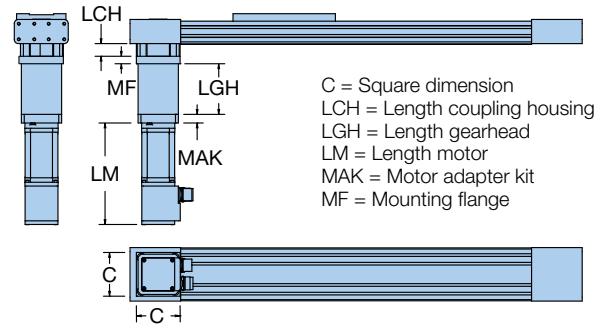

Mounted Gearhead and Mounted Motor

Actuator Size	Order Code		Mounted Motor	Dimensions – mm					
	⑥ ¹	⑨ ²		C	LCH	LGH	LM	MAK	MF
OSPE20BHD	Kx	K0	BE233FJ-KPSN	58	79	67.0	143	22.5	18.5
	Kx	K1	BE233FJ-KPSN w/ brake (CM233FJ-115027)	58	79	67.0	178	22.5	16.5
	Kx	K2	BE344LJ-KPSN	86	79	67.0	188	22.5	18.5
	Kx	K3	BE344LJ-KPSB	86	79	67.0	220	22.5	16.5
	Kx	KC	PM-FBL04AMK	62	79	67	108.2	22.5	18.5
	Kx	KD	MP-FBL04AMK2 (Brake)	62	79	67	148.2	22.5	18.5
OSPE25BHD	Kx	K0	BE233FJ-KPSN	58	22	67.0	143	22.5	13.0
	Kx	K1	BE233FJ-KPSN w/ brake (CM233FJ-115027)	58	22	67.0	178	22.5	13.0
	Kx	K2	BE344LJ-KPSN	86	22	67.0	188	22.5	13.0
	Kx	K3	BE344LJ-KPSB	86	22	67.0	220	22.5	13.0
	Kx		PM-FBL04AMK	62	22	67	108.2	22.5	13
	Kx		MP-FBL04AMK2 (Brake)	62	22	67	148.2	22.5	13
OSPE32BHD	Lx	K2	BE344LJ-KPSN	86	30	85.5	188	20.0	14.0
	Lx	K3	BE344LJ-KPSB	86	30	85.5	220	20.0	14.0
	Lx	M0	MPP0923D1E-KPSN	89	30	85.5	178	28.5	14.0
	Lx	M1	MPP0923D1E-KPSB	89	30	85.5	213	28.5	14.0
	Lx	M2	MPP1003D1E-KPSN	98	30	85.5	175	28.5	14.0
	Lx	M3	MPP1003D1E-KPSB	98	30	85.5	223	28.5	14.0
	Lx	M4	MPP1003R1E-KPSN	98	30	85.5	175	28.5	14.0
	Lx	M5	MPP1003R1E-KPSB	98	30	85.5	223	28.5	14.0
	Lx	KJ	PM-FCL10AMK	80	30	85	152.7	28.5	14
	Lx	KK	PM-FCL10AMK2 (Brake)	80	30	85	193	28.5	14
OSPE50BHD	Mx	K2	BE344LJ-KPSN	86	41	110.0	188	24.0	18.0
	Mx	K3	BE344LJ-KPSB	86	41	110.0	220	24.0	18.0
	Mx	M0	MPP0923D1E-KPSN	89	41	110.0	178	24.0	18.0
	Mx	M1	MPP0923D1E-KPSB	89	41	110.0	213	24.0	18.0
	Mx	M2	MPP1003D1E-KPSN	98	41	110.0	175	24.0	18.0
	Mx	M3	MPP1003D1E-KPSB	98	41	110.0	223	24.0	18.0
	Mx	M4	MPP1003R1E-KPSN	98	41	110.0	175	24.0	18.0
	Mx	M5	MPP1003R1E-KPSB	98	41	110.0	223	24.0	18.0
	Mx	M6	MPP1154B1E-KPSN	113	41	110.0	203	35.0	18.0
	Mx	M7	MPP1154B1E-KPSB	113	41	110.0	252	35.0	18.0
	Mx	M8	MPP1154P1E-KPSN	113	41	110.0	203	35.0	18.0
	Mx	M9	MPP1154P1E-KPSB	113	41	110.0	252	35.0	18.0
	Mx	KJ	PM-FCL10AMK	80	41	110	152.7	35	18
	Mx	KK	PM-FCL10AMK2 (Brake)	80	41	110	193	35	18

¹ When ordering with actuator, use order code ⑥ (see Ordering Information), to specify mounted gearhead size, ratio and orientation:

Gearhead size: **K** = PV60TA **L** = PV90TA **M** = PV115TA

Gearhead ratio and mounting orientation: (Replace "x" to specify)

With mounting position opposite carriage: **1** = ratio 3:1 **2** = ratio 5:1 **3** = ratio 10:1

With mounting position same side as carriage: **4** = ratio 3:1 **5** = ratio 5:1 **6** = ratio 10:1

² Use order code ⑨ (see Ordering Information) to specify choice of mounted motor.

■ Blue order codes indicate rapid shipment availability

Mounted Gearhead with Motor Mounting Kit Options

Mounted Gearhead with Motor Mounting Kits include a coupling housing, flange and gearhead with coupler and flange

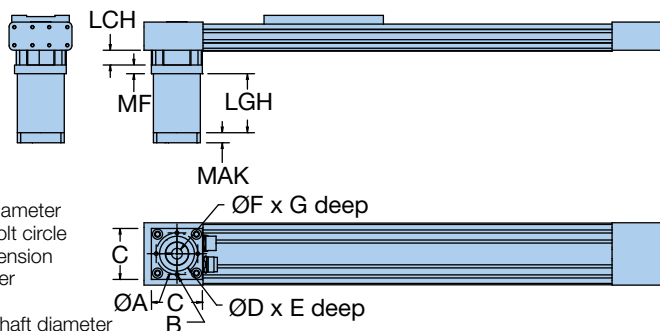

- A = Bolt circle diameter
- B = Screw for bolt circle
- C = Square dimension
- D = Pilot diameter
- E = Pilot depth
- F = Input drive shaft diameter
- G = Input drive shaft length
- LCH = Length coupling housing
- LGH = Length gearhead
- MAK = Motor adapter
- MF = Mounting flange

Belt Driven Tables

Mounted Gearhead with Motor Mounting Kit

Actuator Size	Order Code ⑥ ¹	Order Code ⑨ ²	Dimensions – mm										
			A	B	C	D	E	F	G	LCH	LGH	MAK	MF
OSPE20BHD	Jx	AA	46.66	M3	43	20.00	1.6	6.35	24.8	19	48.5	19.0	9.0
	Jx	AB	66.67	M4	55	38.10	1.6	6.35	20.5	19	48.5	15.7	9.0
	Jx	B5	46.00	M4	43	30.00	2.5	6.00	25.0	19	48.5	19.0	9.0
	Jx	AM	46.00	M4	43	30.00	2.5	8.00	25.0	19	48.5	19.0	9.0
	Jx	B6	63.00	M4	55	40.00	2.5	9.00	20.0	19	48.5	13.7	9.0
	Jx	AH	63.00	M5	55	40.00	2.5	9.00	20.0	19	48.5	19.0	9.0
	Kx	AB	66.67	M5	62	38.10	1.6	6.35	20.5	79	67.0	16.5	18.5
	Kx	AC	66.67	M5	62	38.00	1.6	9.53	20.8	79	67.0	16.5	18.5
	Kx	AF	98.43	M6	85	73.00	3.0	12.70	37.0	79	67.0	30.0	18.5
	Kx	AD	66.67	M5	62	38.10	1.6	9.525	31.8	79	67.0	22.5	18.5
	Kx	AE	98.43	M5	80	73.03	3.0	12.70	30.0	79	67.0	22.5	18.5
	Kx	B6	63.00	M4	62	40.00	2.5	9.00	20.0	79	67.0	16.5	18.5
	Kx	AH	63.00	M5	62	40.00	2.5	9.00	20.0	79	67.0	16.5	18.5
	Kx	B8	70.00	M5	62	50.00	3.0	12.00	30.0	79	67.0	22.5	18.5
	Kx	AN	70.00	M5	62	50.00	3.0	14.00	30.0	79	67.0	22.5	18.5
	Kx	AG	75.00	M5	62	60.00	2.5	11.00	23.0	79	67.0	16.5	18.5
	Kx	B9	75.00	M5	62	60.00	2.5	14.00	30.0	79	67.0	22.5	18.5
	Kx	BB	90.00	M6	80	70.00	3.0	14.00	30.0	79	67.0	22.5	18.5
	Kx	A3	100.00	M6	89	80.00	3.5	14.00	30.0	79	67.0	22.5	18.5

¹ When ordering with actuator, use order code ⑥ (see Ordering Information), to specify mounted gearhead size, ratio and orientation:
 Gearhead size: **J** = PV040TA **K** = PV60TA
 Gearhead ratio and mounting orientation: (Replace "x" to specify)
 With mounting position opposite carriage: **1** = ratio 3:1 **2** = ratio 5:1 **3** = ratio 10:1
 With mounting position same side as carriage: **4** = ratio 3:1 **5** = ratio 5:1 **6** = ratio 10:1
 * 3:1 ratio not available on size OSPE20BHD (with "J" PV040TA gearhead)

² Use order code ⑨ (see Ordering Information), to specify appropriately sized motor mounting kit. See ordering information.

■ Blue order codes indicate rapid shipment availability

(continued on next page)

(continued from previous page)

Mounted Gearhead with Motor Mounting Kit

Actuator Size	Order Code	Order Code	Dimensions — mm										
	⑥ ¹	⑨ ²	A	B	C	D	E	F	G	LCH	LGH	MAK	MF
OSPE25BHD	Kx	AB	66.67	M5	62	38.10	1.6	6.35	20.5	22	67.0	16.5	13
	Kx	AC	66.67	M5	62	38.00	1.6	9.53	20.8	22	67.0	16.5	13
	Kx	AF	98.43	M6	85	73.00	3.0	12.70	37.0	22	67.0	30.0	13
	Kx	AD	66.67	M5	62	38.10	1.6	9.525	31.8	22	67.0	22.5	13
	Kx	AE	98.43	M5	80	73.03	3.0	12.70	30.0	22	67.0	22.5	13
	Kx	B6	63.00	M4	62	40.00	2.5	9.00	20.0	22	67.0	16.5	13
	Kx	AH	63.00	M5	62	40.00	2.5	9.00	20.0	22	67.0	16.5	13
	Kx	B8	70.00	M5	62	50.00	3.0	12.00	30.0	22	67.0	22.5	13
	Kx	AN	70.00	M5	62	50.00	3.0	14.00	30.0	22	67.0	22.5	13
	Kx	AG	75.00	M5	62	60.00	2.5	11.00	23.0	22	67.0	16.5	13
	Kx	B9	75.00	M5	62	60.00	2.5	14.00	30.0	22	67.0	22.5	13
	Kx	BB	90.00	M6	80	70.00	3.0	14.00	30.0	22	67.0	22.5	13
OSPE32BHD	Lx	AE	98.43	M5	90	73.03	3.0	12.70	30.0	30	85.5	20.0	14
	Lx	B6	63.00	M4	90	40.00	2.5	9.00	20.0	30	85.5	20.0	14
	Lx	AH	63.00	M5	90	40.00	2.5	9.00	20.0	30	85.5	20.0	14
	Lx	AN	70.00	M5	90	50.00	3.0	14.00	30.0	30	85.5	20.0	14
	Lx	AG	75.00	M5	90	60.00	2.5	11.00	23.0	30	85.5	20.0	14
	Lx	B9	75.00	M5	90	60.00	2.5	14.00	30.0	30	85.5	20.0	14
	Lx	B0	75.00	M6	90	60.00	3.0	14.00	30.0	30	85.5	20.0	14
	Lx	BB	90.00	M6	90	70.00	3.0	14.00	30.0	30	85.5	20.0	14
	Lx	B4	90.00	M6	90	70.00	3.0	16.00	40.0	30	85.5	28.5	14
	Lx	AP	90.00	M6	90	70.00	3.0	19.00	40.0	30	85.5	28.5	14
	Lx	B3	95.00	M6	90	50.00	2.5	14.00	30.0	30	85.5	20.0	14
	Lx	A3	100.00	M6	90	80.00	3.5	14.00	30.0	30	85.5	20.0	14
	Lx	AL	100.00	M6	90	80.00	3.0	16.00	40.0	30	85.5	28.5	14
	Lx	AJ	100.00	M6	90	80.00	3.0	19.00	40.0	30	85.5	30.0	14
Lx	A4	115.00	M8	100	95.00	3.5	19.00	40.0	30	85.5	28.5	14	
OSPE50BHD	Mx	AE	98.43	M5	115	73.03	3.0	12.70	30.0	41	110.0	24.0	18
	Mx	AG	75.00	M5	115	60.00	2.5	11.00	23.0	41	110.0	24.0	18
	Mx	B4	90.00	M6	115	70.00	3.0	16.00	40.0	41	110.0	35.0	18
	Mx	AP	90.00	M6	115	70.00	3.0	19.00	40.0	41	110.0	35.0	18
	Mx	A3	100.00	M6	115	80.00	3.5	14.00	30.0	41	110.0	24.0	18
	Mx	AL	100.00	M6	115	80.00	3.0	16.00	40.0	41	110.0	24.0	18
	Mx	AJ	100.00	M6	115	80.00	3.0	19.00	40.0	41	110.0	24.0	18
	Mx	A4	115.00	M8	115	95.00	3.5	19.00	40.0	41	110.0	24.0	18
	Mx	BD	130.00	M8	115	95.00	3.0	19.00	40.0	41	110.0	24.0	18
Mx	AK	130.00	M8	115	110.00	3.5	24.00	50.0	41	110.0	35.0	18	

¹ When ordering with actuator, use order code ⑥ (see Ordering Information), to specify mounted gearhead size, ratio and orientation:

Gearhead size: **L** = PV90TA **M** = PV115TA

Gearhead ratio and mounting orientation: (Replace "x" to specify)

With mounting position opposite carriage: **1** = ratio 3:1 **2** = ratio 5:1 **3** = ratio 10:1

With mounting position same side as carriage: **4** = ratio 3:1 **5** = ratio 5:1 **6** = ratio 10:1

² Use order code ⑨ to specify choice of appropriately sized mounted motor. See Ordering Information.

■ Blue order codes indicate rapid shipment availability

End Cap Mounting Options

See "Maximum Permissible Unsupported Length" for end cap and profile mounting placement requirements.

Order Code

A
(1 pair)



Type CN End Cap for OSPE20BHD, OSPE25BHD and OSPE32BHD

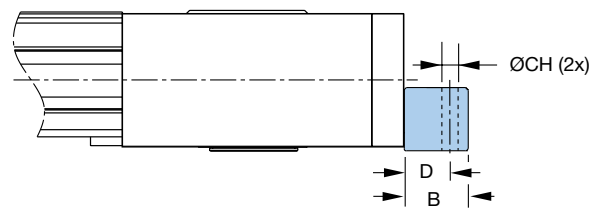
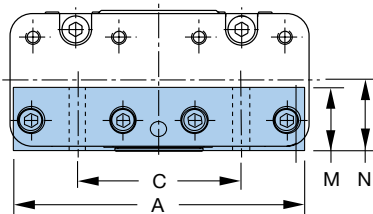

Type CN End Cap for OSPE50BHD

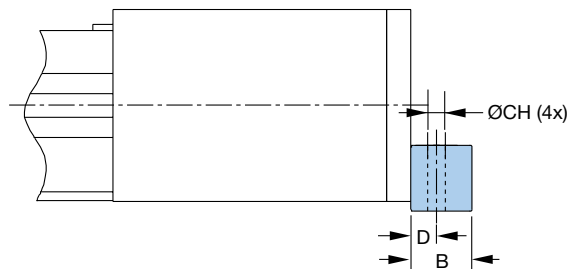
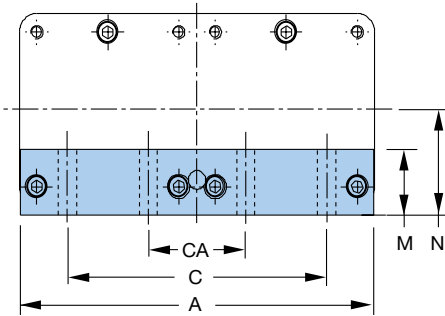

Type CN Top Mounting Block

Actuator Size	Part Number*	Weight* (kg)	Dimensions – mm							
			A	B	C	CA	ØCH	D	M	N
OSPE20BHD	16213FIL	0.165	74	20	40	—	6.6	10.0	20	22
OSPE25BHD	12266FIL	0.311	91	25	52	—	6.6	16.0	25	22
OSPE32BHD	12267FIL	0.500	114	25	64	—	9.0	18.0	25	30
OSPE50BHD	12268FIL	0.847	174	30	128	48	9.0	12.5	30	48

*When ordering with actuator, use order code 10. See Ordering Information. To order as replacement parts (per pair), use part numbers listed). Weights listed are for a single piece.

Belt Driven Tables

Order Code

B
(1 pair)



Type CO End Cap for OSPE20BHD, OSPE25BHD and OSPE32BHD

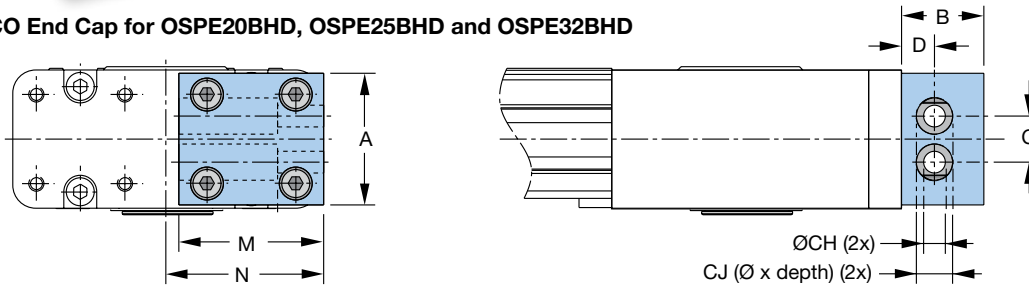

Type CO End Cap for OSPE50BHD

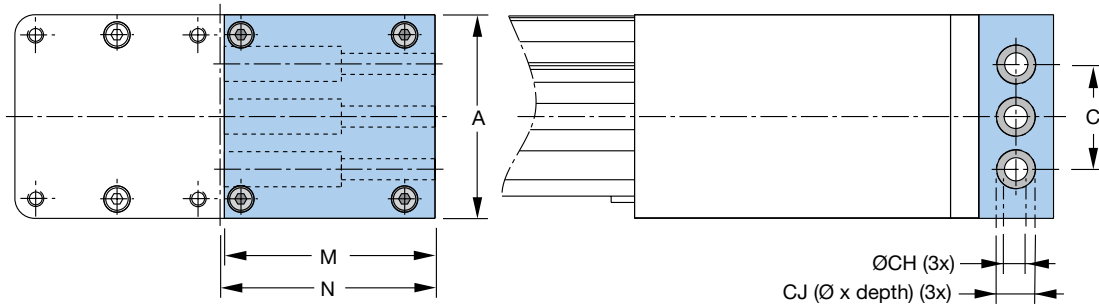

Type CO Side Mounting Block

Actuator Size	Part Number*	Weight* (kg)	Dimensions – mm							
			A	B	C	ØCH	CJ	D	M	N
OSPE20BHD	16241FIL	0.166	40	22	18	6.6	11 x 39	15.0	42	45
OSPE25BHD	16245FIL	0.221	40	25	14	6.6	11 x 30	10.0	44	48
OSPE32BHD	16246FIL	0.450	56	28	19	9.0	15 x 42	12.0	60	62
OSPE50BHD	16247FIL	1.159	87	32	45	9.0	15 x 50	16.0	90	92

*When ordering with actuator, use order code 10. See ordering information, Ordering Information. To order as replacement parts (per pair), use part numbers listed). Weights listed are for a single piece.

Profile Mounting Options

See "Maximum Permissible Unsupported Length" for end cap and profile mounting placement requirements.

Order Code

2, 5, 8 or B
(1, 2, 3 or 4 pair)

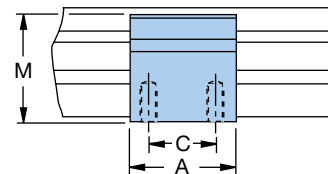
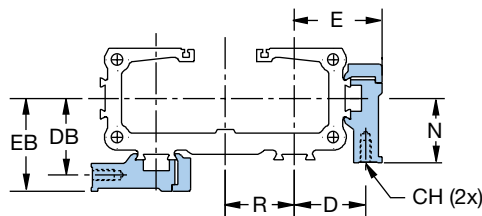
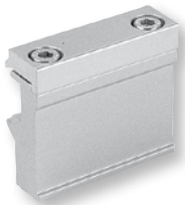

Type D1 (with internal threads)

Actuator Size	Part Number*	Weight* (kg)	Dimensions – mm									
			A	C	CH	D	DB	E	EB	M	N	R
OSPE20BHD	20008FIL	0.061	50	36	M5 x 10	20.5	28.1	28.0	35.6	38	22	23
OSPE25BHD	20008FIL	0.061	50	36	M5 x 10	27.0	28.5	34.5	36.0	38	22	26
OSPE32BHD	20157FIL	0.177	50	36	M5 x 10	33.0	35.5	40.5	43.0	46	30	32
OSPE50BHD	15534FIL	0.167	60	45	M6 x 11	40.0	45.0	52.0	57.0	71	48	44

*When ordering with actuator, use order code ①. See ordering information, Ordering Information. To order replacement parts (per individual unit), use part numbers listed. Part numbers and weights are for a single piece.

Order Code

1, 4, 7 or A
(1, 2, 3 or 4 pair)

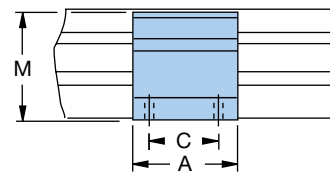
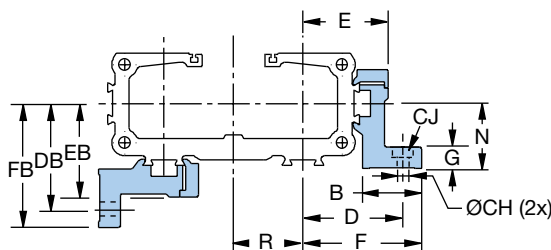

Type E1 (with 2 thru holes)

Actuator Size	Part Number*	Weight* (kg)	Dimensions – mm														
			A	B	C	ØCH	CJ	D	DB	E	EB	F	FB	G	M	N	R
OSPE20BHD	20009FIL	0.074	50	26	36	5.5	10 x 5.7	33.5	41.1	28.0	35.6	41.0	48.6	8	38	22	23
OSPE25BHD	20009FIL	0.074	50	26	36	5.5	10 x 5.7	40.0	41.5	34.5	36.0	47.5	49.0	8	38	22	26
OSPE32BHD	20158FIL	0.092	50	27	36	5.5	10 x 5.7	46.0	48.5	40.5	43.0	54.5	57.0	10	46	30	32
OSPE50BHD	15536FIL	0.189	60	34	45	7.0	—	59.0	64.0	52.0	57.0	67.0	72.0	10	71	48	44

*When ordering with actuator, use order code ①. See ordering information, Ordering Information. To order replacement parts (per individual unit), use part numbers listed. Part numbers and weights are for a single piece.

Belt Driven Tables

Order
Code

3, 6, 9 or C
(1, 2, 3 or 4 pair)

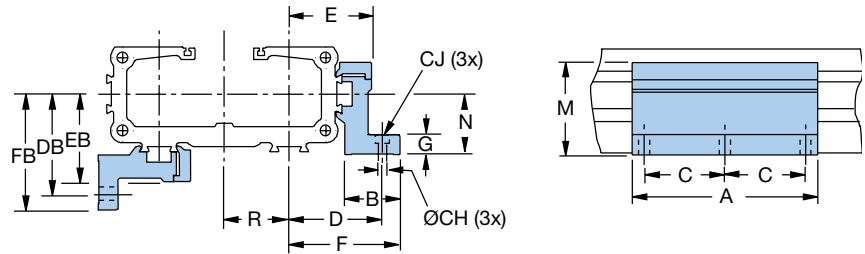
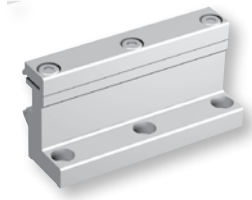

Type MAE (with 3 thru holes)

Actuator Size	Part Number*	Weight* (kg)	Dimensions — mm														
			A	B	C	ØCH	CJ	D	DB	E	EB	F	FB	G	M	N	R
OSPE20BHD	12278FIL	0.271	92	26	40	5.5	10 x 5.7	33.5	41.1	28.0	35.6	41.0	48.6	8	38	22	23
OSPE25BHD	12278FIL	0.271	92	26	40	5.5	10 x 5.7	40.0	41.5	34.5	36.0	47.5	49.0	8	38	22	26
OSPE32BHD	12279FIL	0.334	92	27	40	5.5	10 x 5.7	46.0	48.5	40.5	43.0	54.5	57.0	10	46	30	32
OSPE50BHD	12280FIL	0.668	112	34	45	7.0	—	59.0	64.0	52.0	57.0	67.0	72.0	10	71	48	44

*When ordering with actuator, use order code ⑩. See ordering information, Ordering Information. To order replacement parts (per individual unit), use part numbers listed. Part numbers and weights are for a single piece.

ORDERING INFORMATION

OSPE

Select an order code from each of the numbered fields to create a complete OSPE..BHD model order number. Include hyphens and non-selective characters as shown in example below.

① ② ③ ④ ⑤ ⑥ ⑦ ⑧ ⑨ ⑩ ⑪ ⑫

Order Number Example: OSPE 25 - 6 0 0 02 - 00000 - P 00 0 0 0

① Series

OSPE Origa System Plus Electromechanical

② Actuator Bore Size

20 73 mm W x 49 mm H

25 93 mm W x 53 mm H

32 116 mm W x 67 mm H

50 175 mm W x 93 mm H

③ Drive Train

5 Belt actuator with integrated roller guide
(Available upon request — consult factory)

6 Belt actuator with integrated ball bearing guide

④ Carriage

0 Standard

1 Tandem (two carriages for higher load capabilities)

2 Bi-Parting (two driven carriages with opposing movements)

⑤ Operating Direction and Magnet Position*

(See blue inset box (next page) for parallel actuators operating direction)

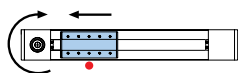
0  Standard (Carriage moves away from drive end)

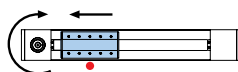
1  Standard (Carriage moves toward drive end)

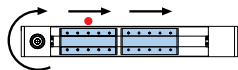
0  Tandem (Carriage moves away from drive end)

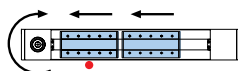
1  Tandem (Carriage moves toward drive end)

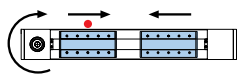
2  Bi-Parting (Carriages move toward mid-actuator)

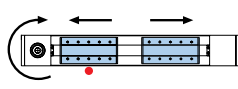
3  Bi-Parting (Carriages move away from mid-actuator)

* Sensors must be mounted in the side or bottom dovetail groove on the same side of the actuator with mounted magnet (•)

⑥ Drive Shaft and Gearhead/Motor Options Configuration and Orientation

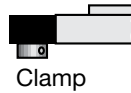
02  Clamp shaft¹ (opposite carriage side)
Clamp

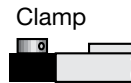
04  Clamp shaft¹ (same side as carriage)
Clamp

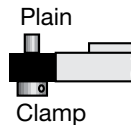
03  Plain shaft² (opposite carriage side) with plain shaft to connect this master actuator in parallel with idler actuator using a link shaft
Clamp

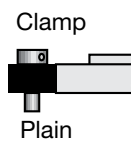
05  Plain shaft² (same side as carriage) with plain shaft to connect this master actuator in parallel with idler actuator using a link shaft
Clamp

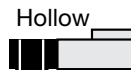
06  Hollow shaft with keyway (opposite carriage side)
Hollow

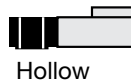
07  Hollow shaft with keyway (same side as carriage)
Hollow

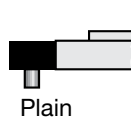
0A  Plain shaft² (opposite carriage side) to connect this idler actuator in parallel with a master actuator using a link shaft
Plain

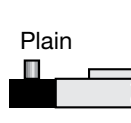
0B  Plain shaft² (same side as carriage) to connect this idler actuator in parallel with a master actuator using a link shaft
Plain

Jx PV040TA
Kx PV060TA
Lx PV090TA
Mx PV115TA
Mounted Gearhead Options³
(replace “x” with appropriate ratio and orientation)

¹ See Options & Accessories for available Gearhead Mounting Kit Options.

² Only available with order code 00 “No gearhead mounting kit or motor option” (item ⑨)

³ Requires motor or motor mounting kit selection for item ⑨ below. See Options & Accessories for “Mounted Gearhead and Motor” or “Mounted Gearhead with Motor Mounting Kit” for details and dimensions

 Blue order codes indicate rapid shipment availability

7 Order Stroke* (see Dimensions)

00000 5-digit input (in mm)

* Maximum standard stroke:

OSPE20BHD = 05760 mm

OSPE25HD = 05700 mm

OSPE32BHD = 05600 mm

OSPE50BHD = 05500 mm

Longer strokes available upon request. Consult factory.

8 Hardware and Cover Strip

P Standard hardware with Parker gold cover strip

9 Gearhead/Motor Mounting Options

00 No gearhead or motor mounting option

Gearhead Mounting Kits (see Options & Accessories for available option dimensions and delivery)

Mounted Gearhead and Motor (see Options & Accessories for available option dimensions and delivery)

Mounted Gearhead with Motor Mounting Kit (see Options & Accessories for available option dimensions and delivery)

10 End Cap Mounting (see Options & Accessories)

0 No end cap mounting

A 1 pair CN (for top carriage mounting)

B 1 pair CO (for side carriage mounting)

11 Profile Mounting (see Options & Accessories)

0 No profile mounting

2 1 pair D1 (with 2 internal threads)

5 2 pair D1 (with 2 internal threads)

8 3 pair D1 (with 2 internal threads)

B 4 pair D1 (with 2 internal threads)

1 1 pair E1 (with 2 thru holes)

4 2 pair E1 (with 2 thru holes)

7 3 pair E1 (with 2 thru holes)

A 4 pair E1 (with 2 thru holes)

3 1 pair MAE (with 3 thru holes)

6 2 pair MAE (with 3 thru holes)

9 3 pair MAE (with 3 thru holes)

C 4 pair MAE (with 3 thru holes)

12 Magnetic Sensor Mounting*

0 No sensor mounting

A 1 pc. N.O., NPN, with M8 connector

B 2 pc. N.C., NPN, with M8 connector

C 1 pc. N.O., NPN, with M8 connector
2 pc. N.C., NPN, with M8 connector

D 1 pc. N.O., PNP, with M8 connector

E 2 pc. N.C., PNP, with M8 connector

F 1 pc. N.O., PNP, with M8 connector
2 pc. N.C., PNP, with M8 connector

* Extension cable with M8 plug and 5 m cable flying lead cable for Sensor with M8 connector can be ordered separately; use part number 003-2918-01

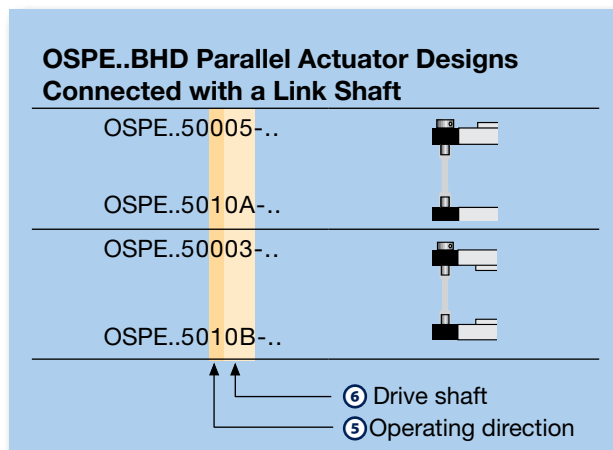

Blue order codes indicate rapid shipment availability

Free sizing and selection support from Virtual Engineer at parker.com/VirtualEngineer



OSPE..B Belt-Driven Actuators

Actuators for Point-to-Point Applications

- Precise path and position control
- High-speed operation
- Easy installation
- Low maintenance
- Ideal for precise point-to-point applications



Belt Driven Tables

Features

- Integrated drive and guidance system
- Tandem carriage with second carriage for increased load capabilities
- Long available strokes
- Complete motor, gearhead and control packages
- Diverse range of accessories and mountings
- Bi-parting carriages and special options available
- Ambient temperature range -30°C to +80°C
- IP 54 rated

PowerSlide

- Designed for harsh environments
- Speed up to 3 m/s
- Hardened steel guide rail
- Carriage with steel v-wheels
- Tough roller cover with wiper and grease access point

ProLine

- Designed for high-speed, precise, smooth and quiet operation
- Aluminum rail with ground and calibrated steel trucks
- Carriage supported by needle bearing rolls
- Integrated wipers to keep bearing system clean
- Lifetime lubricated bearing system

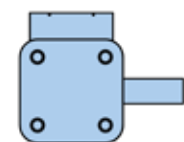

OSPE25BHD

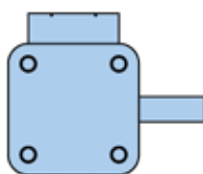

OSPE32BHD

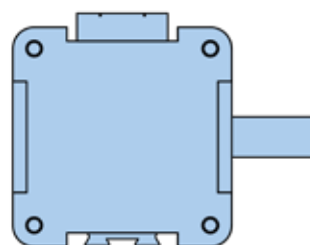

OSPE50BHD

	OSPE25BHD	OSPE32BHD	OSPE50BHD
Maximum Travel (mm)	3,000	5,000	5,000
Maximum Payload F_z (N)	160	300	850
Maximum Acceleration (m/sec ²)	10	10	10

The field-proven OSPE..B design is the industry standard for the widest array of point-to-point linear traverse applications. Compact size and maximum configurability make the OSPE..B easy to

integrate into any machine layout simply and neatly.

To meet rigorous environmental and maximum performance criteria, the OSPE..B Series is optionally available with

the PowerSlide and ProLine external bearing which can be installed in any position (top, side or bottom of the actuator) and retrofitted to existing actuators.

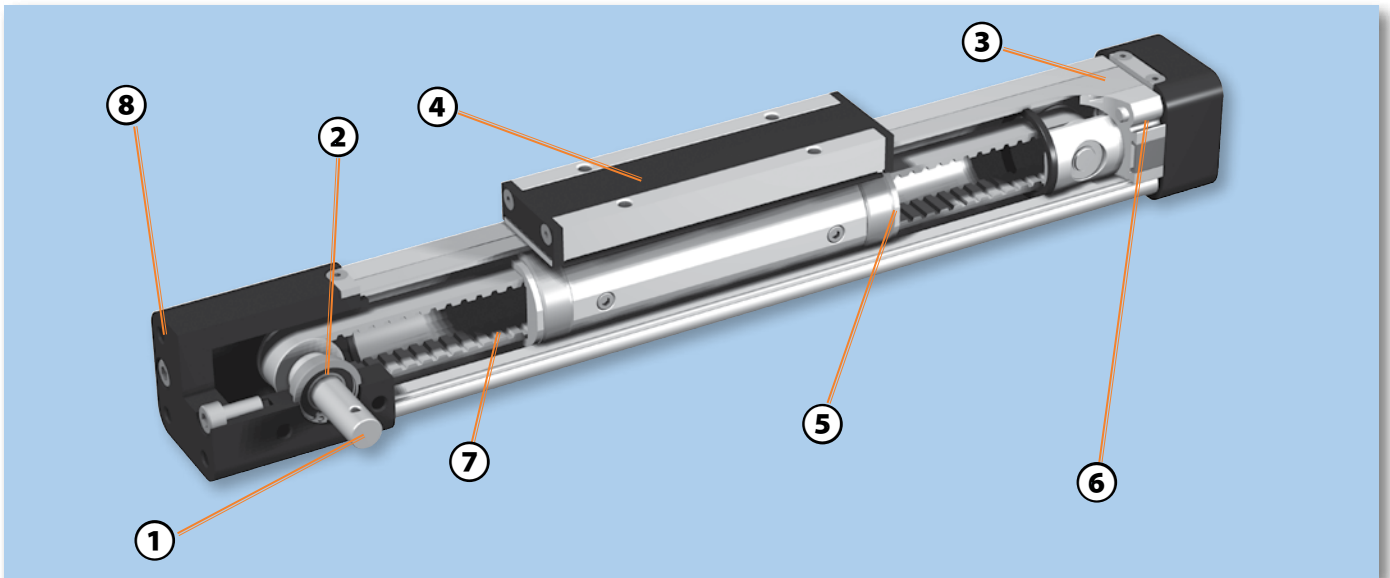

- ① Drive shaft**
Designed to pair with a large assortment of motor and gearhead mounting options
- ② Double row angular contact ball bearing**
Optimized for high thrust force transmission
- ③ Corrosion resistant steel sealing band**
Magnetically fastened to the actuator body and provides sealing to IP54
- ④ Carriage**
Low profile, high strength aluminum carriage with threaded holes for ease of mounting
- ⑤ Low friction support rings**
Polymer glider bushing to provide an economical guidance system with optimum performance
- ⑥ Slotted profile**
With dovetail grooves for strength, actuator mounting, and mounting of sensor and other accessories
- ⑦ Steel reinforced toothed belt**
Moderate force transmission and long life
- ⑧ End housing mounting**
Threaded mounting holes allow for a multitude of mounting options

Carriage Bearing Design Configurations

Standard carriage — with internal glider bearing
 PowerSlide — externally mounted steel roller guide for higher load capabilities specifically in harsh environments
 ProLine — externally mounted aluminum roller guide for higher load capabilities in high speed applications



Optional Carriage Orientation

(for standard carriage only)
 Tandem carriage (for higher load capabilities), bi-parting carriage (for opposing synchronized movements), clevis mounting (provides compensation between actuator and guide rails in machine designs), Inversion mounting (allows outer band to be on the bottom, while keeping payload on top, for better actuator protection in dirty environments)



Actuator Mounting Options

End cap mounting — allows the actuator to be anchored by the end caps
 Profile mounting — supports long travel actuators or for direct mounting



Multi-axis Systems

A wide range of adapter plates and intermediate drive shafts simplifies engineering and installation. Please consult factory for your individual system design.

Drive Shaft Options

Plain drive shaft left, plain drive shaft right, or double plain drive shaft to connect master unit with idler unit

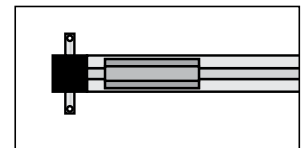

Options and Accessories

Information on all OSPE..B Series options are detailed in Options & Accessories. Simply select all the options needed to solve your application requirements, then order with the actuator using convenient order codes (see Ordering Information). To order an option separately as an upgrade to an existing system or as a replacement part, use the individual option part numbers provided.

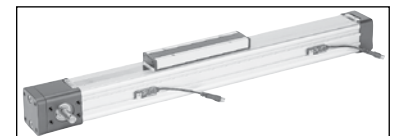

OSPE..B

Actuator Size			OSPE25B	OSPE32B	OSPE50B
Travel Distance per Rev	s_{lin}	mm	60	60	100
Pulley Diameter		mm	19.10	19.10	31.83
Linear Speed (Max)	v_{max}	m/s	2	3	5 ¹
Acceleration (Max)	a_{max}	m/s ²	10	10	10
Repeatability (unidirectional)		μm	± 50	± 50	± 50
Thrust Force (Max)	F_{Amax}	N	50	150	425
		lbs	11	34	96
Torque on Drive Shaft (Max)	M_{Amax}	Nm	0.9	1.9	7.4
		in-lb	8	17	65
Inertia	J_0	kgmm ²	25	43	312
		kgmm ² /m	6.6	10.0	45.0
		kgmm ² /kg	91	91	253
Ambient Temperature Range		°C	-30 to +80		
IP Rating)			IP 54		

¹ Maximum linear speed for OSPE50B with PowerSlide bearing is 3 m/s

Belt Driven Tables

Available Thrust Force

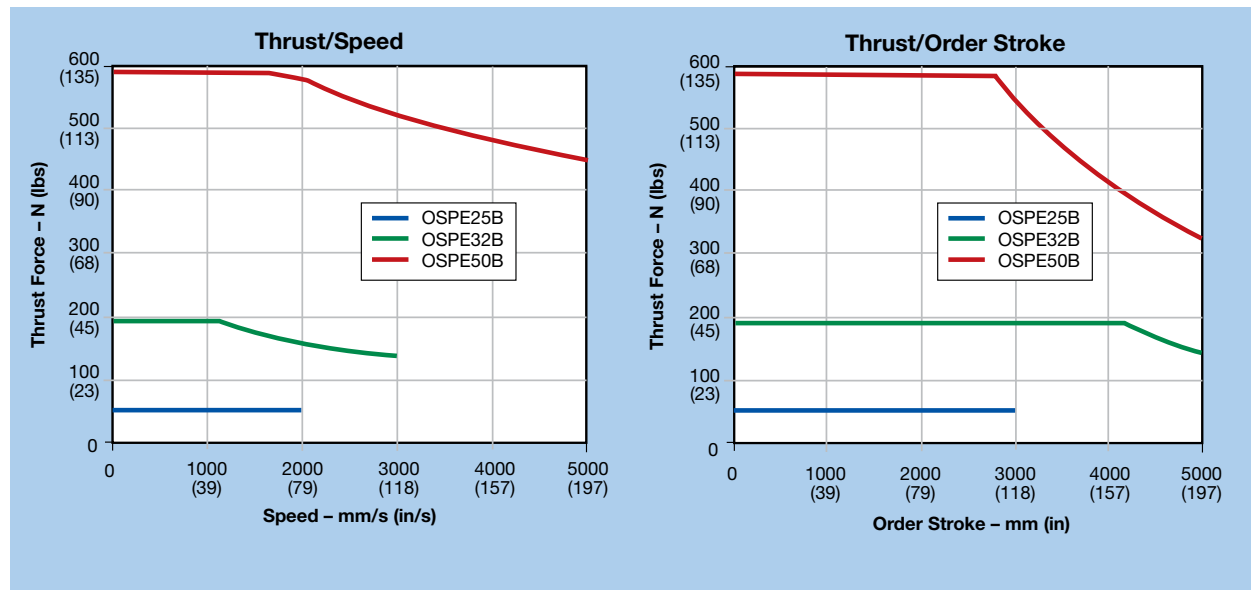

Calculating Load Factors - Combined Normal and Moment Load

The sum of combined loads (static and dynamic) must not exceed "1" at any time as shown in the formula below:

$$\frac{F_z}{F_z(\max)} + \frac{M_x}{M_x(\max)} + \frac{M_y}{M_y(\max)} + \frac{M_z}{M_z(\max)} \leq 1$$

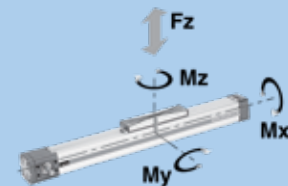

- $M = F \times l$ (Nm)
- $M_x = M_{x\text{ static}} + M_{x\text{ dynamic}}$
- $M_y = M_{y\text{ static}} + M_{y\text{ dynamic}}$
- $M_z = M_{z\text{ static}} + M_{z\text{ dynamic}}$

OSPE25B Performance

Carriage (Bearing System)			Standard Carriage	PowerSlide			ProLine
				PS25/25	PS25/35	PS25/44	PL25
Part Number ¹			—	20304	20305	20306	20874
Max Order Stroke ²	OS _{max}	mm	3000	3000	3000	3000	3000
Normal Load ³ (Max)	F _Y / F _Z	N (lbs)	160 (36)	197 (44)	219 (49)	387 (87)	1549 (348)
Moment Load ³ (Max)	M _X	Nm (in-lb)	2 (18)	3 (27)	4 (35)	6 (53)	30 (266)
	M _Y	Nm (in-lb)	12 (106)	14 (124)	15 (133)	57 (504)	69 (611)
	M _Z	Nm (in-lb)	8 (71)	14 (124)	15 (133)	57 (504)	69 (611)
Torque — No Load ⁴	M ₀	Nm (in-lb)	0.4 (4)	0.6 (5)	0.6 (5)	0.6 (5)	0.6 (5)
@ 0 Stroke	m ₀	kg (lbs)	0.7 (1.54)	1.0 (2.20)	1.1 (2.42)	1.3 (2.86)	0.9 (1.98)
Weight Per Meter of Stroke	m _{OS}	kg (lbs)	1.6 (3.52)	3.0 (6.60)	3.4 (7.48)	4.2 (9.24)	3.3 (7.26)
Carriage ⁴	m _C	kg (lbs)	0.2 (0.44)	0.9 (1.98)	1.0 (2.20)	1.7 (3.74)	1.0 (2.20)

OSPE32B Performance

Carriage (Bearing System)			Standard Carriage	PowerSlide		ProLine
				PS32/35	PS32/44	PL32
Part Number ¹			—	20307	20308	20875
Max Order Stroke ²	OS _{max}	mm	5000	3500	3500	3750
Normal Load ³ (Max)	F _Y / F _Z	N (lbs)	300 (67)	303 (68)	747 (168)	2117 (476)
Moment Load ³ (Max)	M _X	Nm (in-lb)	8 (71)	4 (35)	16 (142)	52 (460)
	M _Y	Nm (in-lb)	25 (221)	15 (133)	57 (504)	132 (1168)
	M _Z	Nm (in-lb)	16 (142)	15 (133)	57 (504)	132 (1168)
Torque — No Load ⁴	M ₀	Nm (in-lb)	0.5 (4)	0.8 (7)	0.8 (7)	0.8 (7)
@ 0 Stroke	m ₀	kg (lbs)	1.5 (2.64)	1.9 (4.18)	2.1 (4.62)	2.0 (4.40)
Weight Per Meter of Stroke	m _{OS}	kg (lbs)	3.2 (7.04)	5.1 (11.22)	5.9 (12.98)	5.8 (12.76)
Carriage ⁴	m _C	kg (lbs)	0.4 (0.88)	1.2 (2.64)	1.9 (4.18)	1.6 (3.52)

OSPE50B Performance

Carriage (Bearing System)			Standard Carriage	PowerSlide		ProLine
				PS50/60	PS50/76	PL50
Part Number ¹			—	20309	20310	20876
Max Order Stroke ²	OS _{max}	mm	5000	3500	3500	3750
Normal Load ³ (Max)	F _Y / F _Z	N (lbs)	850 (191)	975 (219)	1699 (382)	5626 (1265)
Moment Load ³ (Max)	M _X	Nm (in-lb)	16 (142)	29 (257)	59 (522)	201 (1779)
	M _Y	Nm (in-lb)	80 (708)	81 (717)	149 (1319)	451 (3992)
	M _Z	Nm (in-lb)	32 (283)	81 (717)	149 (1319)	451 (3992)
Torque — No Load ⁴	M ₀	Nm (in-lb)	0.6 (5)	0.9 (8)	0.9 (8)	0.9 (8)
@ 0 Stroke	m ₀	kg (lbs)	4.2 (9.24)	5.5 (12.10)	6.3 (13.86)	5.4 (11.88)
Weight Per Meter of Stroke	m _{OS}	kg (lbs)	6.2 (13.64)	10.4 (22.88)	12.8 (28.16)	10.0 (22.00)
Carriage ⁴	m _C	kg (lbs)	1.0 (2.20)	3.3 (7.26)	5.9 (12.98)	3.5 (7.70)

¹ PowerSlide or ProLine guide bearings can be ordered individually with assigned part number in the table and specified, five digit order stroke value (mm), following the part number (-nnnnn) to designate the appropriate length guide rail. To order PowerSlide or Proline bearing with the actuator, use the appropriate order in item ⑩

² Longer strokes available upon request. Contact factory.

³ Load and moment based on 8000 km performance Refer to "Calculating Load Factors" for additional information.

⁴ For tandem and bi-parting options, double the values listed.

Maximum Permissible Unsupported Length — Determining end cap and profile mounting placement

OSPE..B Series actuators need to be mounted onto a solid machine base or frame structure using appropriately positioned end cap and profile mounts. This ensures that the actuator will not undergo excessive deflection based on the application's load and length requirements.

The greater the load and/or the longer the length between mounts, the more the actuator is susceptible to deflection. Deflection is also dependent on the carriage orientation (F_z for top oriented carriage or F_y for a side mounted carriage).

Standard Carriage, Tandem Carriage, PowerSlide or ProLine

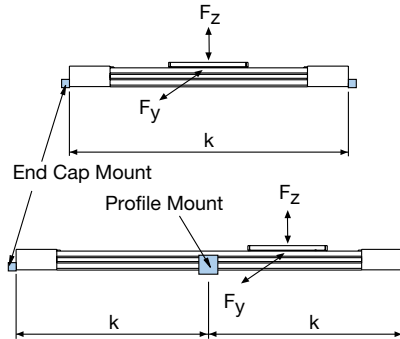

To determine correct end cap and profile mount placement, please follow the steps shown in the example below.

Bi-Parting Carriage

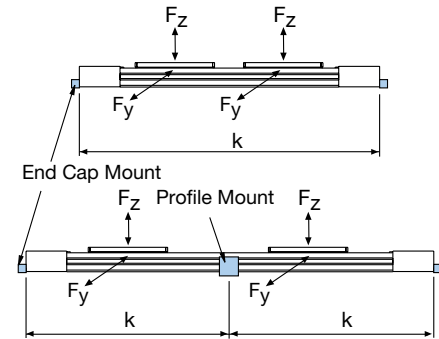

Use the deflection graphs (next page), to ensure that the load will not exceed the maximum allowed deflection.

Belt Driven Tables

Example:

A horizontal application uses an OSPE32B with a top oriented carriage. The maximum load to the carriage is 10 kg and the order stroke is 3,700 mm (see Dimensions to calculate order stroke).

Therefore, the overall length of the actuator will be 4,000 mm:

$$3,700 \text{ mm} + 2 \times \text{Dim "X"} (150 \text{ mm}) = 4,000 \text{ mm}$$

- 1) Use the appropriate F_z graph (next page) for a top loaded carriage. (Note: with the standard carriage, top loaded F_z and side loaded F_y values are the same).
- 2) Calculate the Load " F " in Newtons based on the 10 kg application load requirement:

$$10 \text{ kg} \times 9.81 \text{ kg/ms}^2 = 98.1 \text{ N}$$

- 3) Draw a line from 98 N on the Y-axis to the OSPE32B curve, then down to the X-axis.
- 4) The value of " k " is approximately 3,600 mm.
- 5) Since the overall length (4,000 mm) is greater than this value " k ", the actuator will require an additional third fixture point — two end cap mounts and one profile mount — equally spaced to create a distance " k " of 2000 mm in between.
- 6) Maximum deflection of the actuator with this mounting configuration will be less than 4 mm:

$$0.2\% \text{ of } 2,000 \text{ mm} = 4 \text{ mm}$$

Standard Carriage Load-Distance

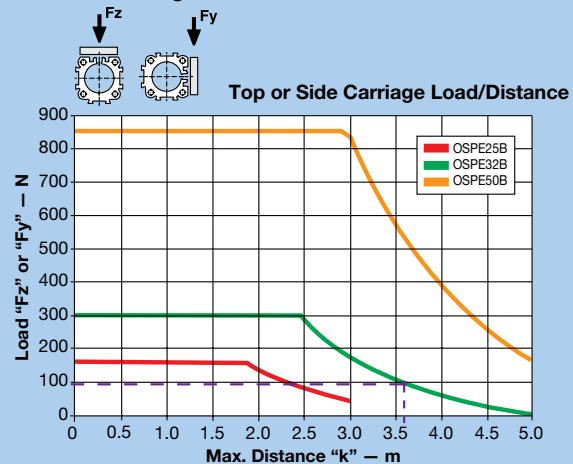

To further reduce deflection:

If the application requires less deflection, then simply reduce the distance " k " appropriately. In this example, for instance, the application must not exceed 2 mm (1/2 the maximum deflection calculated). Therefore, " k " must also be 1/2, or 1000 mm.

To achieve this reduced maximum deflection, the actuator will require five fixture points — two end cap mounts and three profile mounts — equally spaced with a distance " k " of 1000 mm in between.

Standard Carriage Load-Distance

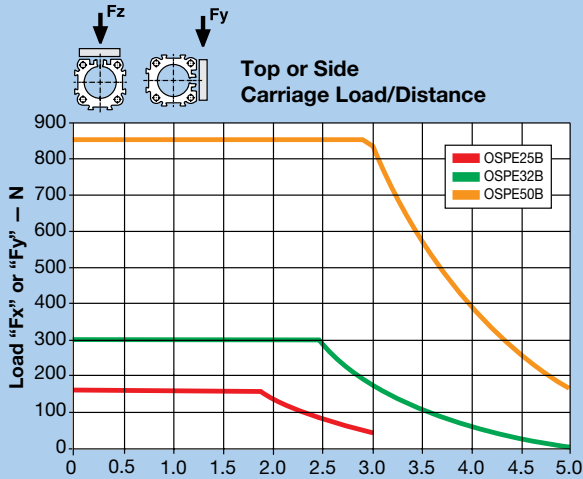

Maximum Permissible Unsupported Length

Determining end cap and profile mounting placement

Use the appropriate deflection graph to ensure that the application load does not exceed the deflection curve. Supporting the actuator within the recommended maximum distance “k” will ensure that the installation will have a maximum deflection equal to 0.2% of distance “k.”

To further reduce deflection, simply reduce the distance between end cap and profile mounts as described in the example on the previous page.

PowerSlide Carriage Load-Distance

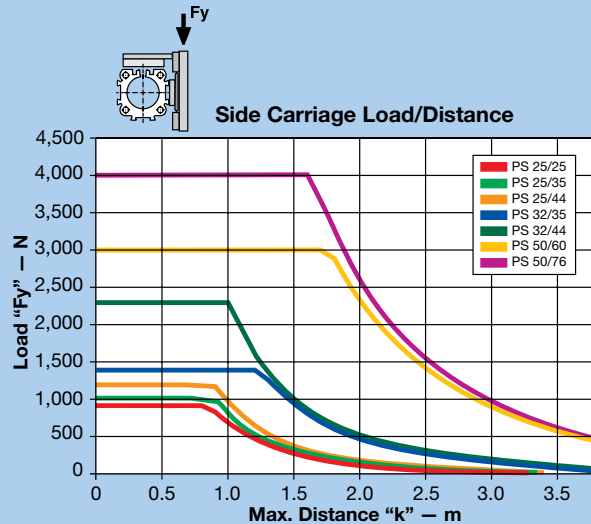
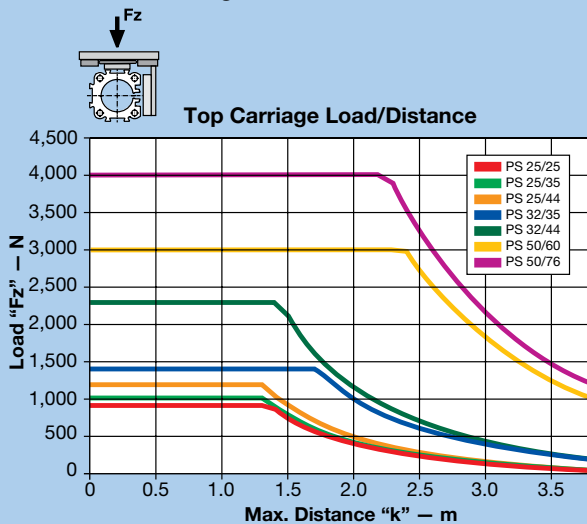

ProLine Carriage Load-Distance

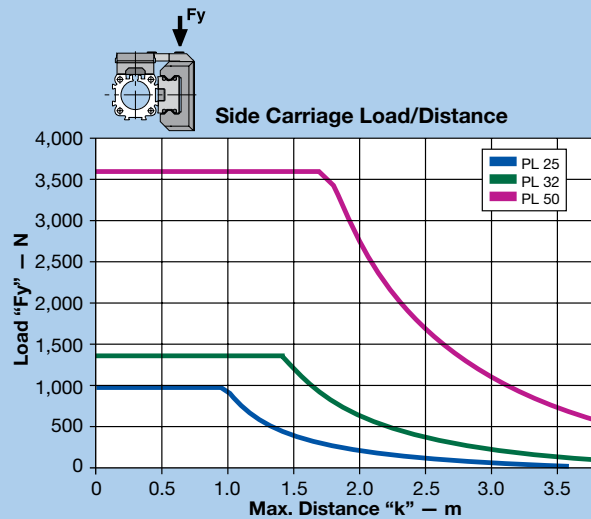
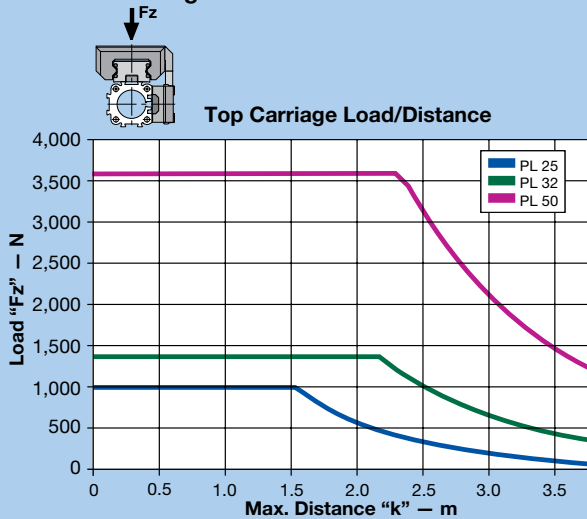

DIMENSIONS

Download 2D & 3D files from
www.parker.com/emn



DIMENSIONS

Base Unit Dimensions w/Standard Carriage

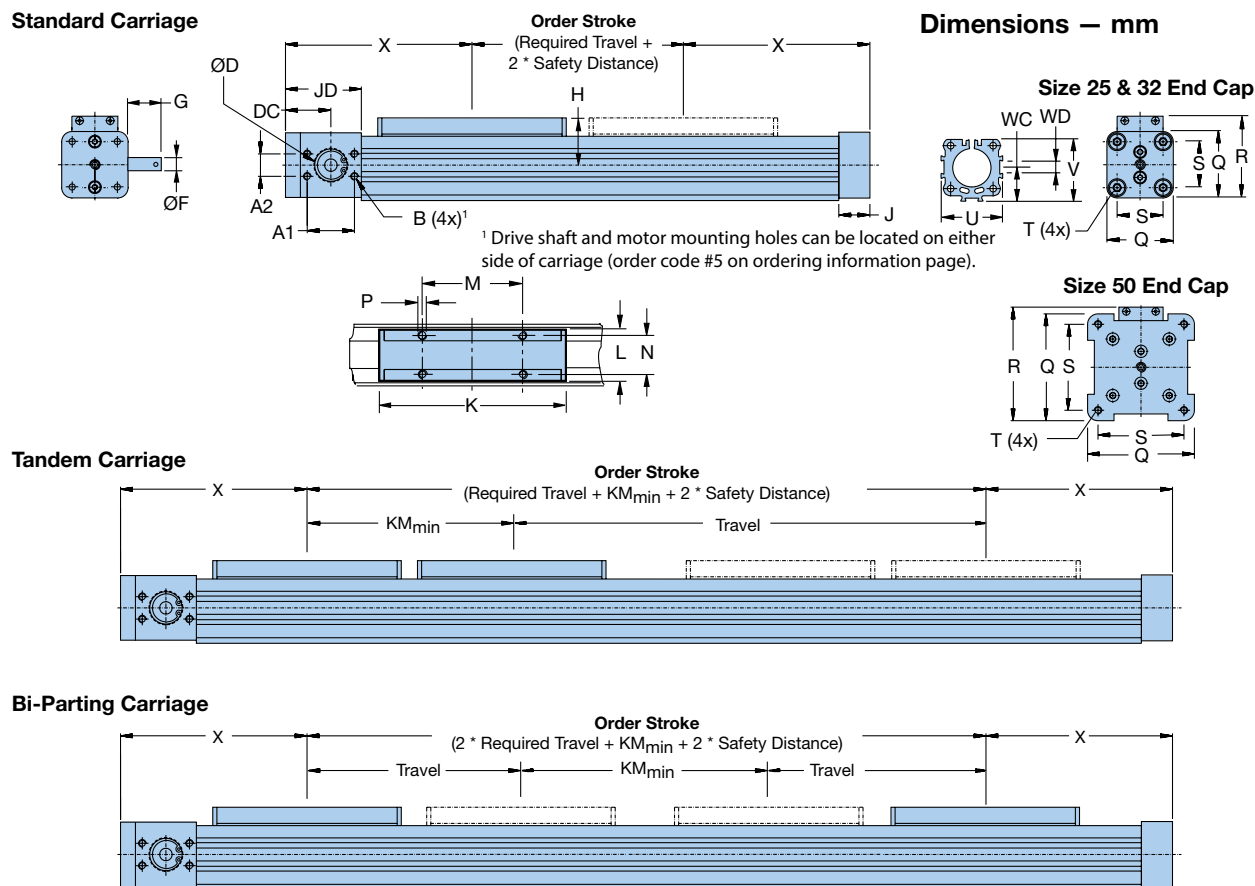

Belt Driven
Tables

* See Options & Accessories for clevis mount and inversion mount optional carriage dimensions.

Actuator Size	A	A1	A2	B	D	DC	F	G	H	J	JD	K
OSPE25B	33.5	30	15	M5 x 10	19 ^{H7}	37.0	10 _{j6}	24	31	22	57	117
OSPE32B	42.0	38	18	M6 x 12	26 ^{H7}	36.5	10 _{j6}	26	38	25	61	152
OSPE50B	59.4	50	32	M8 x 16	40 ^{H7}	48.5	16 _{h8}	34	49	25	85	200

	L	H	N	P	Q	R	S	T	U	V	WC	WD	X
OSPE25B	33	65	25	M5 x 8	41	52.5	27	M5 x 10	40	39.5	21.5	10.4	125
OSPE32B	36	90	27	M6 x 10	52	66.5	36	M6 x 12	52	51.7	28.5	10.4	150
OSPE50B	36	110	27	M6 x 10	87	92.5	70	M6 x 12	76	77	43.0	10.4	200

Order Stroke Dimensional Requirements

Actuator Size	KM _{min}	KM _{rec}
OSPE25B	130	190
OSPE32B	170	230
OSPE50B	220	320

KM_{min} is the minimum distance between two carriages possible; KM_{rec} is the recommended distance for optimal performance.

Order Stroke Safety Distance:

The mechanical end position should not be used as a mechanical end stop, thus an additional **Safety Distance** at both ends of travel must be incorporated into the Order Stroke. The safety distance for servo-driven systems is equivalent to the travel distance per revolution of the drive shaft. AC motor-driven systems with VFD require a larger safety distance than servo systems. For further information and design assistance, please consult factory.



PowerSlide Dimensions

Dimensions – mm

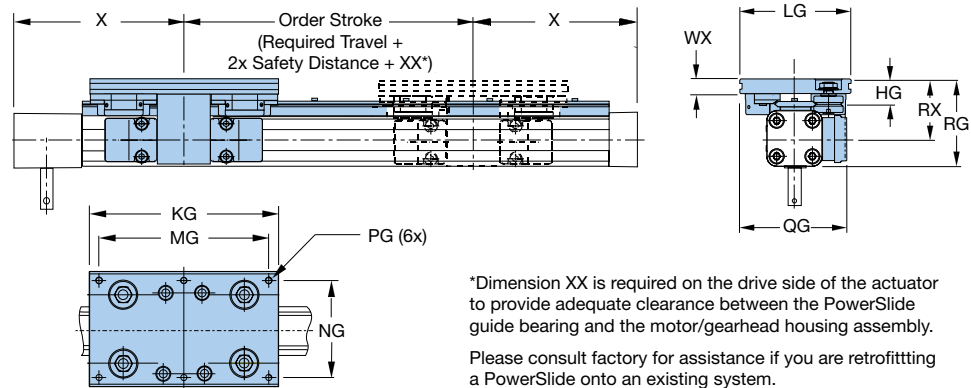

Guide Rail Size	HG	KG	LG	MG	NG	PG	QG	RG	RX	WX	X	XX
PS25/25	20.0	145	80	125	64	M6 x 11	79.5	73.5	53.0	11.0	125	5
PS25/35	21.5	156	95	140	80	M6 x 12	89.5	73.0	52.5	12.5	125	10
PS25/44	26.0	190	116	164	96	M8 x 15	100.0	78.5	58.0	15.0	125	27
PS32/35	21.5	156	95	140	80	M6 x 12	95.5	84.5	58.5	12.5	150	—
PS32/44	26.0	190	116	164	96	M8 x 15	107.0	90.0	64.0	15.0	150	6
PS50/60	28.5	240	135	216	115	M8 x 17	130.5	123.5	81.0	17.0	200	5
PS50/76	39.0	280	185	250	160	M10 x 20	155.5	135.5	93.0	20.0	200	25

ProLine Dimensions

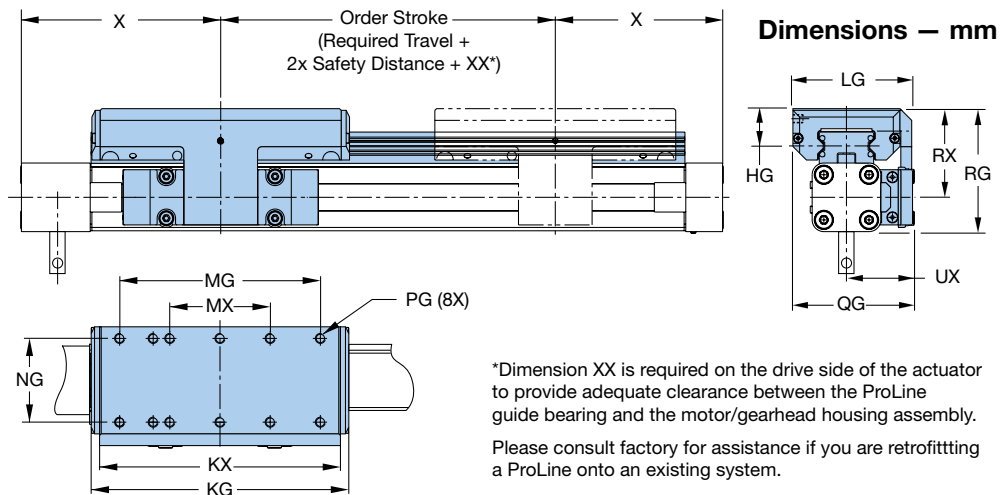

Guide Rail Size	HG	KG	KX	LG	MG	MX	NG	PG	QG	RG	RX	UX	X	XX
PL25	23	154	144	64	120	60	50	M6 x 12	72.5	74	53	40.5	125	10
PL32	25	197	187	84	160	80	64	M6 x 12	91.0	88	62	49.0	150	11
PL50	29	276	266	110	240	120	90	M6 x 16	117.0	118	75	62.0	200	24

Order Code

R Clevis Mounting Option for Standard Carriage

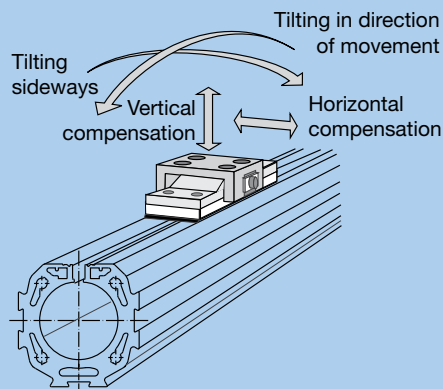
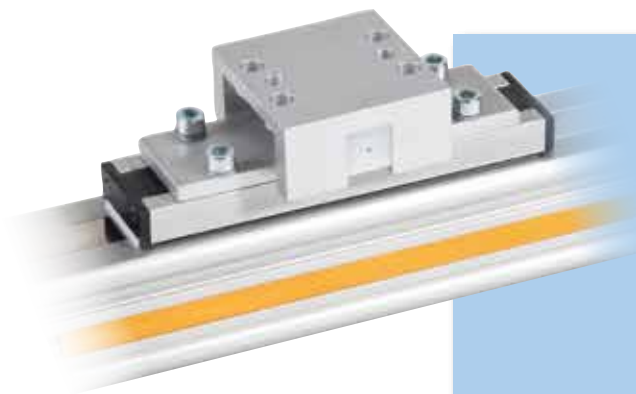

The aluminum clevis mount option bolts directly to the standard carriage to eliminate parallelism deviations and strain to the carriage when the actuator is mounted onto machine guide rails. Clevis mounting provides compensation for misalignment in Z and Y directions and can tilt around the X and Y axis.

When external guides are involved in the application, slight parallelism deviations can lead to mechanical strain on the carriage and actuator. This can be avoided by the use of a clevis mount that provides freedom of movement compensation on several axes.

Belt Driven Tables

OSPE25 and OSPE32

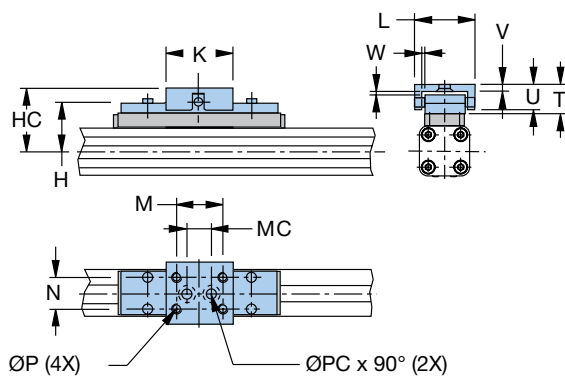

OSPE50

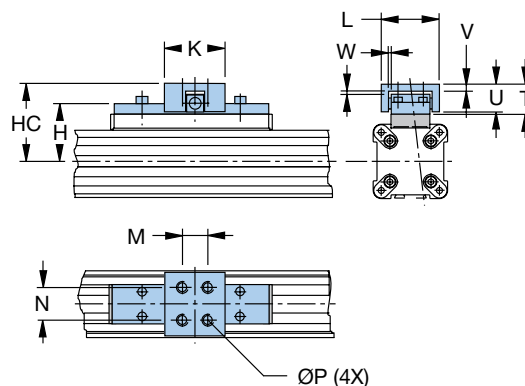

Dimensions — mm

Actuator Size	Part Number*	Weight* (kg)	H	HC	K	L	M	MC	N	P	PC	T	U	V	W
OSPE25B	20005FIL	0.091	39	52	40	38	30	16	16	M5	5.5	21	19	3.5	2
OSPE32B	20096FIL	0.091	50	68	60	62	46	40	25	M6	6.6	30	28	6.0	2
OSPE50B	20097FIL	0.308	61	79	60	62	46	—	25	M6	—	30	28	6.0	2

*Part number and weight are for individual unit.

Order
Code

M Inversion Mounting Option for Standard Carriage



For dirty environments or space-restricted installations, inversion of the actuator is recommended.

The aluminum inversion bracket transfers the driving force to the opposite side of the actuator

allowing the load to be attached to the top side of the actuator while the carriage and sealing band remain protected on the bottom side. The size and position of the mounting holes are the same as on the standard carriage.

Note: Profile mounts and magnetic switches can only be used on the free side of the actuator.

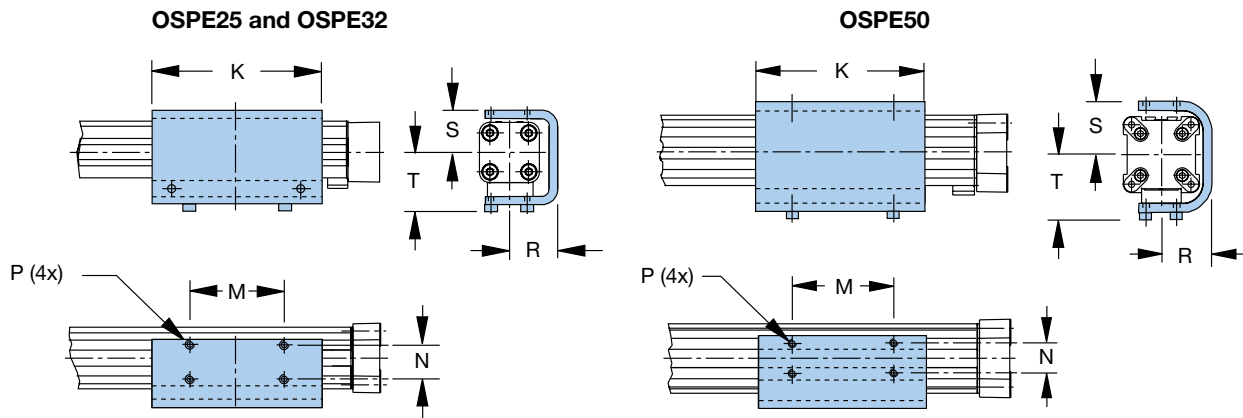

Actuator Size	Part Number*	Weight* (kg)	Dimensions – mm						
			K	M	N	P	R	S	T
OSPE25B	20037FIL	0.302	117	65	25	M5 x 6	33.5	31	31
OSPE32B	20161FIL	0.449	150	90	27	M6 x 6	39.5	38	38
OSPE50B	20166FIL	0.947	200	110	27	M6 x 8	52.0	55	55

*Part number and weight are for individual unit.

Motor Mounting Kit Options

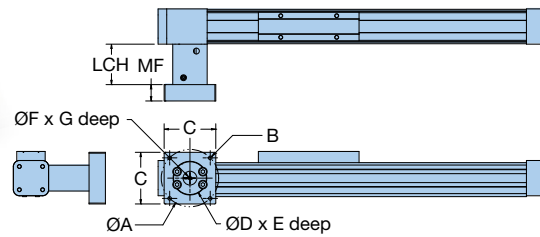

- A = Bolt circle diameter
- B = Screw for bolt circle
- C = Square dimension
- D = Pilot diameter
- E = Pilot depth
- F = Input drive shaft diameter
- G = Input drive shaft length
- LCH = Length coupling housing
- MF = Motor flange

Motor Mounting Kits include a coupling housing, coupling and flange

Note: Screw thread to mount motor to flange plate is M3

Belt Driven Tables

Actuator Size	Order Code ⑥*	Order Code ⑦*	Dimensions — mm								
			A	B	C	D	E	F	G	LCH	MF
OSPE25B	0	AA	46.66	M3	41	20.00	1.6	6.35	24.8	47	12
	0	AB	66.67	M4	55	38.10	1.6	6.35	20.5	47	9
	0	AC	66.67	M5	60	38.10	1.6	9.53	20.8	47	9
	0	AD	66.67	M5	60	38.10	1.6	9.525	31.8	47	19
	0	B5	46.00	M4	60	30.00	2.5	6.00	25.0	47	12
	0	AM	46.00	M4 ¹	41	30.00	2.5	8.00	25.0	47	12
	0	B6	63.00	M4	60	40.00	2.5	9.00	20.0	47	10
	0	AH	63.00	M5	60	40.00	2.5	9.00	20.0	47	12
	0	A2	63.00	M5	60	40.00	2.5	11.00	23.0	47	12
	0	B7	70.00	M5	60	50.00	3.0	8.00	25.0	47	17
	0	B8	70.00	M5	60	50.00	3.0	12.00	30.0	47	17
	0	AG	75.00	M5	70	60.00	2.5	11.00	23.0	47	10
OSPE32B	0	B1	90.00	M5	75	60.00	2.5	11.00	23.0	47	10
	0	AB	66.67	M5	60	38.10	1.6	6.35	20.5	49	10
	0	AC	66.67	M5	60	38.10	1.6	9.525	20.8	49	10
	0	AD	66.67	M5	60	38.10	1.6	9.525	31.8	49	18
	0	AE	98.43	M5	85	73.03	3.0	12.70	30.0	49	16
	0	AF	98.43	M6	85	73.03	3.0	12.70	37.0	49	26
	0	B6	63.00	M4	55	40.00	2.5	9.00	20.0	49	11
	0	AH	63.00	M5	60	40.00	2.5	9.00	20.0	49	11
	0	A2	63.00	M5	60	40.00	2.5	11.00	23.0	49	11
	0	BJ	66.67	M5	60	38.10	1.6	12.70	20.0	49	10
	0	B7	70.00	M5	60	50.00	3.0	8.00	25.0	49	16
	0	B8	70.00	M5	60	50.00	3.0	12.00	30.0	49	16
	0	AN	70.00	M5	60	50.00	3.0	14.00	30.0	49	16
	0	AG	75.00	M5	70	60.00	2.5	11.00	23.0	49	11
	0	B9	75.00	M5	70	60.00	2.5	14.00	30.0	49	16
	0	BA	75.00	M5	70	60.00	3.0	16.00	40.0	49	26
	0	B0	75.00	M6	70	60.00	3.0	14.00	30.0	49	16
	0	B1	90.00	M5	75	60.00	2.5	11.00	23.0	49	11
	0	B2	90.00	M5	75	60.00	2.5	14.00	30.0	49	16
	0	BB	90.00	M6	80	70.00	3.0	14.00	30.0	49	16
0	B4	90.00	M6	80	70.00	3.0	16.00	40.0	49	26	
0	B3	95.00	M6	80	50.00	2.5	14.00	30.0	49	16	

*When ordering with actuator, use order code ⑥ (gearhead designation) and order code ⑦ to specify motor mounting kit. See Ordering Information.

■ Blue order codes indicate rapid shipment availability

(continued on next page)

(continued from previous page)

Actuator Size	Order Code ⑥*	Order Code ⑦*	Dimensions – mm								
			A	B	C	D	E	F	G	LCH	MF
OSPE50B	0	AF	98.43	M6	85	73.03	3.0	12.70	37.0	76	15
	0	AE	98.43	M5	88	73.03	3.0	12.70	30.0	67	14
	0	B9	75.00	M5	75	60.00	2.5	14.00	30.0	67	14
	0	BA	75.00	M5	70	60.00	3.0	16.00	40.0	76	15
	0	B0	75.00	M6	75	60.00	3.0	14.00	30.0	67	14
	0	B2	90.00	M5	80	60.00	2.5	14.00	30.0	67	14
	0	BB	90.00	M6	80	70.00	3.0	14.00	30.0	67	14
	0	B4	90.00	M6	80	70.00	3.0	16.00	40.0	76	15
	0	AP	90.00	M6	80	70.00	3.0	19.00	40.0	76	15
	0	B3	95.00	M6	85	50.00	2.5	14.00	30.0	67	14
	0	A1	99.00	M6	88	73.00	3.0	9.525	31.5	67	14
	0	A3	100.00	M6	90	80.00	3.5	14.00	30.0	67	14
	0	AL	100.00	M6	88	80.00	3.0	16.00	40.0	76	15
	0	AJ	100.00	M6	88	80.00	3.0	19.00	40.0	76	15
	0	A4	115.00	M8	100	95.00	3.5	19.00	40.0	76	15
	0	BD	130.00	M8	115	95.00	3.0	19.00	40.0	76	15
	0	BF	130.00	M8	115	110.00	3.5	19.00	40.0	76	15

*When ordering with actuator, use order code ⑥ (gearhead designation) and order code ⑦ to specify motor mounting kit. See Ordering Information.

■ Blue order codes indicate rapid shipment availability

Mounted Motor Options



Mounted Motor Options include a coupling housing, coupling, flange and motor

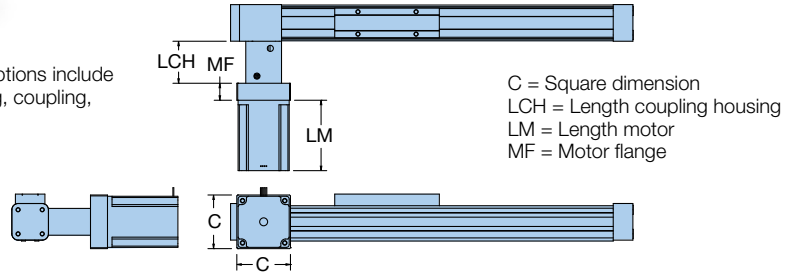

Belt Driven Tables

Actuator Size	Order Code ⑥*	Order Code ⑦*	Motor description	Dimensions — mm			
				C	LCH	LM	MF
OSPE25B	0	L0	LV233-01-10	58	47	79	9
	0	L1	HV233-01-10	58	47	79	9
	0	K0	BE233FJ-KPSN	58	47	143	19
	0	K1	BE233FJ-KPSN with brake (CM233FJ-115027)	58	47	178	19
OSPE32B	0	L0	LV233-01-10	58	49	79	10
	0	L1	HV233-01-10	58	49	79	10
	0	L2	LV343-03-10	86	49	127	26
	0	L3	HV343-01-10	86	49	127	26
	0	K0	BE233FJ-KPSN	58	49	143	18
	0	K1	BE233FJ-KPSN with brake (CM233FJ-115027)	58	49	178	18
	0	K2	BE344LJ-KPSN	86	49	188	16
	0	K3	BE344LJ-KPSB	86	49	220	16
	0	KC	PM-FBL04AMK	62	49	108.2	16
	0	KD	PM-FBL04AMK2 (Brake)	62	49	148.2	16
OSPE50B	0	L2	LV343-03-10	86	76	127	15
	0	L3	HV343-01-10	86	76	127	15
	0	K2	BE344LJ-KPSN	86	67	188	14
	0	K3	BE344LJ-KPSB	86	67	220	14
	0	KJ	PM-FCL10AMK	80	76	152.7	15
	0	KK	PM-FCL10AMK2 (Brake)	80	76	193	15
	0	M0	MPP0923D1E-KPSN	89	76	178	15
	0	M1	MPP0923D1E-KPSB	89	76	212	15
	0	M2	MPP1003D1E-KPSN	98	76	175	15
	0	M3	MPP1003D1E-KPSB	98	76	224	15
	0	M4	MPP1003R1E-KPSN	98	76	175	15
0	M5	MPP1003R1E-KPSB	98	76	224	15	

*When ordering with actuator, use order code ⑥ (gearhead designation) and order code ⑦ to specify mounted motor. See Ordering Information.

Gearhead Mounting Kit Options

Gearhead Mounting Kits include a coupling housing, coupling and flange

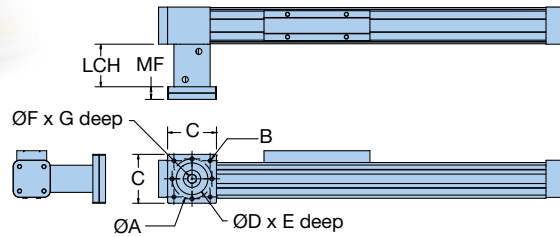

A = Bolt circle diameter
 B = Screw for bolt circle
 C = Square dimension
 D = Pilot diameter
 E = Pilot depth
 F = Input drive shaft diameter
 G = Input drive shaft length
 LCH = Length coupling housing
 MF = Motor flange

Actuator Size	Order Code ⑥*	Order Code ⑦*	Dimensions — mm									
			A	B	C	D	E	F	G	LCH	MF	
OSPE25B	0	C0	44	S4	54	35	3	12	25	47	14.0	
OSPE32B	0	C0	44	S4	60	35	3	12	25	49	14.5	
	0	C1	62	S5	75	52	8	16	36	49	23.0	
OSPE50B	0	C1	62	S5	75	52	8	16	36	76	18.5	
	0	C2	80	S6	95	68	10	22	46	76	23.0	

*When ordering with actuator, use order code ⑥ (gearhead designation) and order code ⑦ to specify gearhead mounting kit. See Ordering Information.

■ Blue order codes indicate rapid shipment availability

Mounted Gearhead with Motor Mounting Kit Options

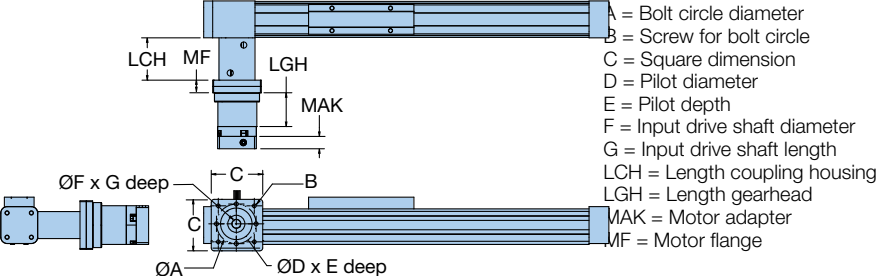

Mounted Gearhead with Motor Mounting Kit include a coupling housing, coupling, flange, and gearhead with coupler and flange

Belt Driven Tables

Actuator Size	Order Code ⑥ ¹	Order Code ⑦ ²	Dimensions – mm										
			A	B	C	D	E	F	G	LCH	LGH	MAK	MF
OSPE25B	A or B	AA	46.66	M3	43	20.00	1.6	6.35	24.8	47	48.5	19.0	14.0
	A or B	AB	66.67	M5	55	38.10	1.6	6.35	20.5	47	48.5	15.7	14.0
	A or B	B5	46.00	M4	43	30.00	2.5	6.00	25.0	47	48.5	19.0	14.0
	A or B	AM	46.00	M4	43	30.00	2.5	8.00	25.0	47	48.5	19.0	14.0
	A or B	B6	63.00	M4	55	40.00	2.5	9.00	20.0	47	48.5	13.7	14.0
	A or B	AH	63.00	M5	55	40.00	2.5	9.00	20.0	47	48.5	19.0	14.0
OSPE32B	C, D or E	AB	66.67	M5	62	38.10	1.6	6.35	20.5	49	67.0	16.5	23.0
	C, D or E	AC	66.67	M5	62	38.00	1.6	9.53	20.8	49	67.0	16.5	23.0
	C, D or E	AD	66.67	M5	62	38.10	1.6	9.525	31.8	49	67.0	22.5	23.0
	C, D or E	AE	98.43	M5	80	73.03	3.0	12.70	30.0	49	67.0	22.5	23.0
	C, D or E	AF	98.43	M6	85	73.03	3.0	12.70	37.0	49	67.0	30.0	23.0
	C, D or E	B6	63.00	M4	62	40.00	2.5	9.00	20.0	49	67.0	16.5	23.0
	C, D or E	AH	63.00	M5	62	40.00	2.5	9.00	20.0	49	67.0	16.5	23.0
	C, D or E	B8	70.00	M5	62	50.00	3.0	12.00	30.0	49	67.0	22.5	23.0
	C, D or E	AN	70.00	M5	62	50.00	11.0	14.00	30.0	49	67.0	22.5	23.0
	C, D or E	AG	75.00	M5	62	60.00	2.5	11.00	23.0	49	67.0	16.5	23.0
	C, D or E	B9	75.00	M5	62	60.00	2.5	14.00	30.0	49	67.0	22.5	23.0
	C, D or E	BB	90.00	M6	80	70.00	3.0	14.00	30.0	49	67.0	22.5	23.0
OSPE50B	C, D or E	AB	66.67	M5	62	38.10	1.6	6.35	20.5	76	67.0	16.5	18.5
	C, D or E	AC	66.67	M5	62	38.00	1.6	9.53	20.8	76	67.0	16.5	18.5
	C, D or E	AD	66.67	M5	62	38.10	1.6	9.525	31.8	76	67.0	22.5	18.5
	C, D or E	AE	98.43	M5	80	73.03	3.0	12.70	30.0	76	67.0	22.5	18.5
	C, D or E	AF	98.43	M6	85	73.03	3.0	12.70	37.0	76	67.0	30.0	18.5
	C, D or E	B6	63.00	M4	62	40.00	2.5	9.00	20.0	76	67.0	16.5	18.5
	C, D or E	AH	63.00	M5	62	40.00	2.5	9.00	20.0	76	67.0	16.5	18.5
	C, D or E	B8	70.00	M5	62	50.00	3.0	12.00	30.0	76	67.0	22.5	18.5
	C, D or E	AN	70.00	M5	62	50.00	3.0	14.00	30.0	76	67.0	22.5	18.5
	C, D or E	AG	75.00	M5	62	60.00	2.5	11.00	23.0	76	67.0	16.5	18.5
	C, D or E	B9	75.00	M5	62	60.00	2.5	14.00	30.0	76	67.0	22.5	18.5
	C, D or E	BB	90.00	M6	80	70.00	3.0	14.00	30.0	76	67.0	22.5	18.5
C, D or E	A3	100.00	M6	89	80.00	3.5	14.00	30.0	76	67.0	22.5	18.5	

¹ When ordering with actuator, use order code ⑥ to specify mounted gearhead size and ratio: **A** PV40TA-005 (ratio 5:1); **B** PV40TA-010 (ratio 10:1); **C** PV60TA-003 (ratio 3:1); **D** PV60TA-005 (ratio 5:1); **E** PV60TA-010 (ratio 10:1). See Ordering Information.
² When ordering with actuator, use order code ⑦ to specify motor mounting kit. See Ordering Information.

■ Blue order codes indicate rapid shipment availability

Mounted Gearhead and Motor Options

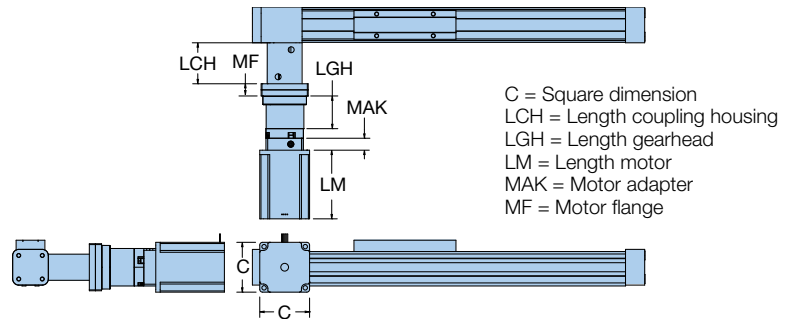

Mounted Gearhead and Mounted Motor Options include a coupling housing, coupling, flange, gearhead with coupler, flange and motor

Actuator Size	Order Code		Motor description	Dimensions — mm					
	⑥ ¹	⑦ ²		C	LCH	LGH	LM	MAK	MF
OSPE25B	A or B	L0	LV233-01-10	58	47	48.5	79	15.7	14.0
	A or B	L1	HV233-01-10	58	47	48.5	79	15.7	14.0
	A or B	KA	PM-FAL01AM8N	40	47	48.5	95.2	19.0	14.0
	A or B	KB	PM-FAL01AM8N2 (Brake)	40	47	48.5	131.6	19.0	14.0
OSPE32B	C, D or E	L0	LV233-01-10	58	49	67.0	79	16.5	23.0
	C, D or E	L1	HV233-01-10	58	49	67.0	79	16.5	23.0
	C, D or E	L2	LV343-03-10	86	49	67.0	127	30.0	23.0
	C, D or E	L3	HV343-01-10	86	49	67.0	127	30.0	23.0
	C, D or E	K0	BE233FJ-KPSN	58	49	67.0	143	22.5	23.0
	C, D or E	K1	BE233FJ-KPSN w/ brake (CM233FJ-115027)	58	49	67.0	178	22.5	23.0
	C, D or E	K2	BE344LJ-KPSN	86	49	67.0	188	22.5	23.0
	C, D or E	K3	BE344LJ-KPSB	86	49	67.0	220	22.5	23.0
	C, D or E	KC	PM-FBL04AMK	62	49	67	108.2	22.5	23.0
	C, D or E	KD	PM-FBL04AMK2 (Brake)	62	49	67	148.2	22.5	23.0
OSPE50B	C, D or E	L0	LV233-01-10	58	76	67.0	79	16.5	18.5
	C, D or E	L1	HV233-01-10	58	76	67.0	79	16.5	18.5
	C, D or E	L2	LV343-03-10	86	76	67.0	127	30.0	18.5
	C, D or E	L3	HV343-01-10	86	76	67.0	127	30.0	18.5
	C, D or E	K0	BE233FJ-KPSN	58	76	67.0	143	22.5	18.5
	C, D or E	K1	BE233FJ-KPSN w/ brake (CM233FJ-115027)	58	76	67.0	178	22.5	18.5
	C, D or E	K2	BE344LJ-KPSN	86	76	67.0	188	22.5	18.5
	C, D or E	K3	BE344LJ-KPSB	86	76	67.0	220	22.5	18.5
	C, D or E	KC	PM-FBL04AMK	62	76	67	108.2	22.5	18.5
	C, D or E	KD	PM-FBL04AMK2 (Brake)	62	76	67	148.2	22.5	18.5

¹ When ordering with actuator, use order code ⑥ to specify mounted gearhead size and ratio: **A** PV40TA-005 (ratio 5:1); **B** PV40TA-010 (ratio 10:1); **C** PV60TA-003 (ratio 3:1); **D** PV60TA-005 (ratio 5:1); **E** PV60TA-010 (ratio 10:1). See Ordering Information.

² When ordering with actuator, use order code ⑦ to specify mounted motor on gearhead. See Ordering Information.

End Cap Mounting Options

See "Maximum Permissible Unsupported Length" for end cap mounting placement requirements.

End Cap Mounting Selection Overview

Type	Standard Carriage			PowerSlide						ProLine			
	25	32	50	25/25	25/35	25/44	32/35	32/44	50/60	50/76	25	32	50
Standard 	A1	•	•										
	A2										•	•	
	A3				•	•		•					
Reinforced 	B1	•	•	•	•	•	•	•			•	•	
	B4							•	•				
Block 	C1			•					•	•			•
	C2												•
	C3								•				
	C4									•			

• Recommended for mounting position with carriage on top • Recommended for mounting position carriage side only (3 or 9 o'clock position)

Order Code

1, 2 or 3
(1 pair)

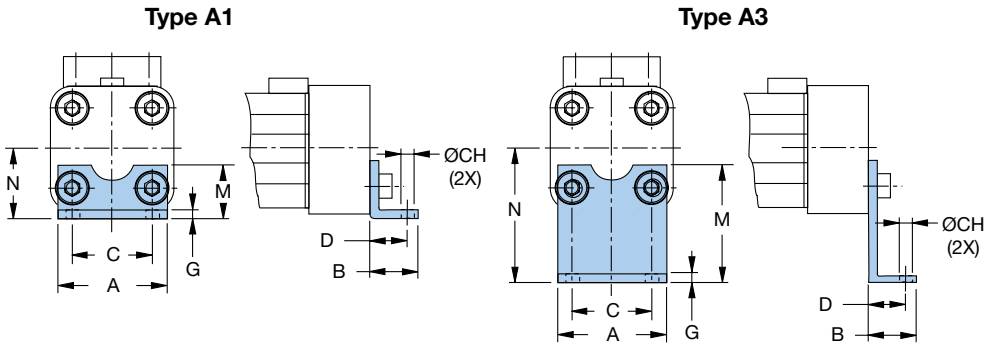

Type A1, A2 and A3 – Standard End Cap

Actuator Size	Type	Part Number*	Weight* (kg)	Dimensions – mm								
				A	B	C	CH	D	G	M	N	
OSPE25B	A1	18156FIL	0.031								18	22
	A2	18157FIL	0.044	39	22	27	5.8	16	2.5		33	37
	A3	18158FIL	0.055								45	49
OSPE32B	A1	18161FIL	0.050								20	30
	A2	18162FIL	0.066	50	26	36	6.6	18	3.0		34	44
	A3	18163FIL	0.159								42	52

*Part number and weight are for individual piece.

Order Code

4 or 5
(1 pair)

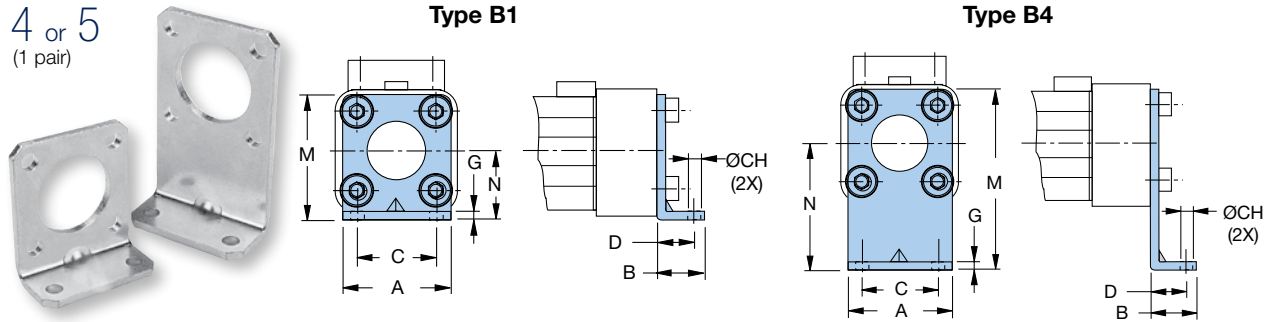

Type B1 and B4 – Reinforced End Cap

Actuator Size	Type	Part Number*	Weight* (kg)	Dimensions – mm							
				A	B	C	CH	D	G	M	N
OSPE25B	B1	18159FIL	0.010	39	22	27	5.8	16	2.5	42	22
	B4	18160FIL	0.110							80	60
OSPE32B	B1	18164FIL	0.078	50	26	36	6.6	18	3.0	55	30
	B4	18165FIL	0.380							85	60

*Part number and weight are for individual piece.

Order Code

1, 2, 3 or 4
(1 pair)

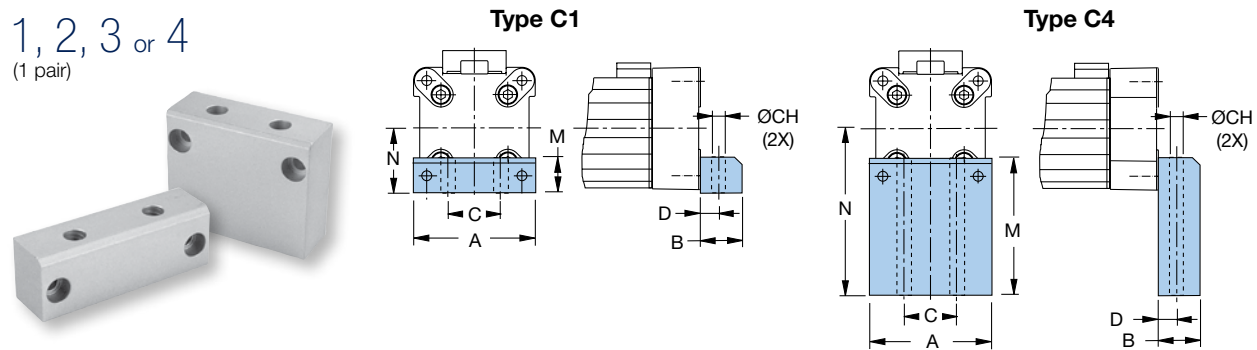

Type C1, C2, C3 and C4 – Block End Cap



Actuator Size	Type	Part Number*	Weight* (kg)	Dimensions – mm						
				A	B	C	CH	D	M	N
OSPE50B	C1	18166FIL	0.146	86	24	40	9.0	12.5	30	48
	C2	18167FIL	0.210						39	57
	C3	18168FIL	0.300						54	72
	C4	18169FIL	0.412						77	95

*Part number and weight are for individual piece.

Profile Mounting Options

See "Maximum Permissible Unsupported Length" for end cap and profile mounting placement requirements.

Profile Mounting Selection Overview

Type	Standard Carriage			PowerSlide								ProLine		
	25	32	50	25/25	25/35	25/44	32/35	32/44	50/60	50/76	25	32	50	
 2 Internal Threads D1	•	•	•	•	•	•	•	•	•	•	•	•	•	
 2 Thru Holes E1 E2 E3 E4	•	•	•	•	•	•	•	•	•	•	•	•	•	
				•	•		•		•		•	•	•	
						•		•		•				
							•			•				
 3 Thru Holes MAE	•	•	•	•	•	•	•	•	•	•	•	•	•	

• Recommended for mounting position with carriage on top • Recommended for mounting position carriage side only (3 or 9 o'clock position)

Belt Driven Tables

Order Code

2, 5 or 8
(1, 2 or 3 pair)

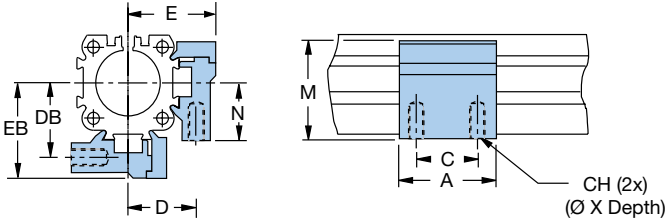

Type D1 (with two internal threads)

Actuator Size	Part Number*	Weight* (kg)	Dimensions — mm									
			A	C	CH	D	DB	E	EB	M	N	
OSPE25B	20008FIL	0.061	50	36	M5 x 10	27	28.5	34.5	36	38	22	
OSPE32B	20157FIL	0.072	50	36	M5 x 10	33	35.5	40.5	43	46	30	
OSPE50B	20162FIL	0.167	60	45	M6 x 11	40	45.0	52.0	57	71	48	

*Part number and weight are for individual piece.

Order Code

E1 1, 4 or 7 (1, 2 or 3 pair) E3 L, P or S (1, 2 or 3 pair)
 E2 K, N or R (1, 2 or 3 pair) E4 M, Q or T (1, 2 or 3 pair)

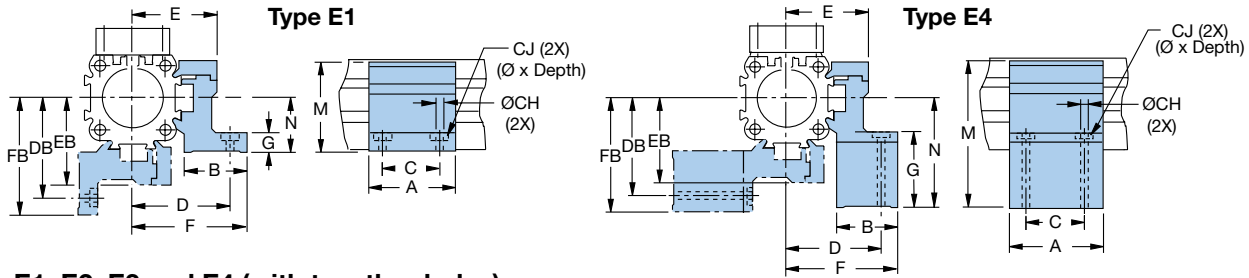
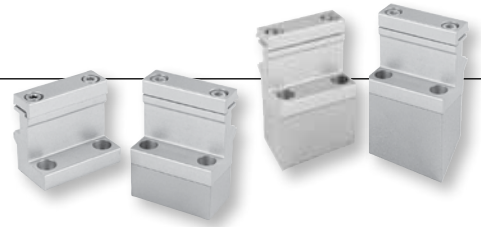

Type E1, E2, E3 and E4 (with two thru holes)

Dimensions — mm

Actuator Size	Part Number*	Weight* (kg)	A	B	C	CH	CJ	D	DB	E	EB	F	FB	G	M	N
OSPE25B	E1 20009FIL	0.074												8	38	22
	E2 20352FIL	0.125	50	26	36	5.5	10 x 5.7	40	41.5	34.5	36	47.5	49	23	53	37
	E3 20353FIL	0.120												35	65	49
	E4 20354FIL	0.020												46	76	60
OSPE32B	E1 20158FIL	0.092												10	46	30
	E2 20355FIL	0.141	50	27	36	5.5	10 x 5.7	46	48.5	40.5	43	54.5	57	24	60	44
	E3 20356FIL	0.140												32	68	52
	E4 20357FIL	0.197												40	76	60
OSPE50B	E1 20163FIL	0.189												10	71	48
	E2 20361FIL	0.235	60	34	45	7.0	—	59	64.0	52.0	57	67.0	72	19	80	57
	E3 20362FIL	0.338												31	95	72
	E4 20363FIL	0.442												57	118	95

*Part number and weight are for individual piece.

Order Code

3, 6 or 9 (1, 2 or 3 pair)

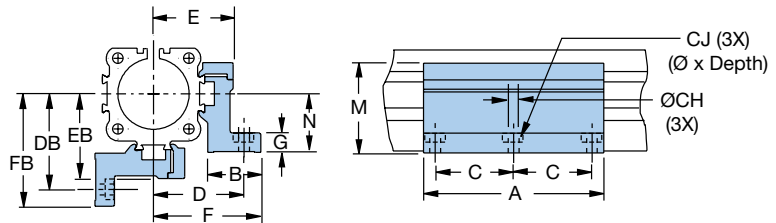
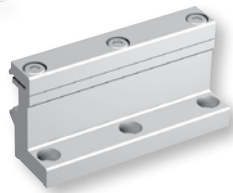

Type MAE (with three thru holes)

Dimensions — mm

Actuator Size	Part Number*	Weight* (kg)	A	B	C	CH	CJ	D	DB	E	EB	F	FB	G	M	N
OSPE25B	12278FIL	0.271	92	26	40	5.5	10 x 5.7	40	41.5	34.5	36	47.5	49	8	38	22
OSPE32B	12279FIL	0.334	92	27	40	5.5	10 x 5.7	46	48.5	40.5	43	54.5	57	10	46	30
OSPE50B	12280FIL	0.668	112	34	45	7.0	—	59	64.0	52.0	57	67.0	72	10	71	48

*Part number and weight are for individual piece.

ORDERING INFORMATION

OSPE

Select an order code from each of the numbered fields to create a complete OSPE..B model order number. Include hyphens and non-selective characters as shown in example below.

1
2
3
4
5
6
7
8
9
10
11
12
13
14

Order Number Example: OSPE 25 - 0 0 0 0 0 - 00000 - P 0 0 0 0 0

Belt Driven Tables

1 Series

OSPE Origa System Plus Electromechanical

2 Actuator Bore Size

- 25** 41 mm W x 53 mm H
- 32** 52 mm W x 67 mm H
- 50** 87 mm W x 93 mm H

3 Drive Train

0 Belt actuator with internal glider bearing

4 Carriage

- 0** Standard
- 1** Tandem (two carriages for higher load capabilities)
- 2** Bi-Parting (two driven carriages for opposing movements)

5 Drive Shaft and Motor Input

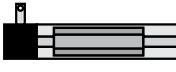
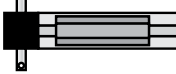
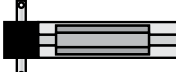
- 0**  Plain shaft, motor input left
- 1**  Plain shaft, motor input right
- 2**  Double plain shaft, motor input left
- 3**  Double plain shaft, motor input right

6 Mounted Gearhead Options

- 0** No gearhead
- A** PV40TA-005 (gear ratio 5:1)*
- B** PV40TA-010 (gear ratio 10:1)*
- C** PV60TA-003 (gear ratio 3:1)*
- D** PV60TA-005 (gear ratio 5:1)*
- E** PV60TA-010 (gear ratio 10:1)*

* Requires selection from "Mounted Gearhead with Motor Mounting Kit" or "Mounted Gearhead and Motor" (see Options & Accessories) for item **7** below.

7 Gearhead/Motor Mounting Options

- 0 -** No gearhead or motor mounting option
 Motor Mounting Kits (see Options & Accessories for available option dimensions and delivery)
 Mounted Motors (see Options & Accessories for available option dimensions and delivery)
 Gearhead Mounting Kits (see Options & Accessories for available option dimensions and delivery)
 Mounted Gearhead with Motor Mounting Kit (see Options & Accessories for available option dimensions and delivery)
 Mounted Gearhead and Motor (see Options & Accessories for available option dimensions and delivery)

8 Order Stroke*

00000 5-digit input (in mm)
 * See Dimensions to calculate required order stroke.
 Maximum catalog stroke:
 OSPE25B = 03000 mm;
 OSPE32B and OSPE50B = 05000 mm
 Longer strokes available upon request. Consult factory.

9 Hardware and Dovetail Groove Covers

P Standard hardware with Parker gold cover strip

■ Blue order codes indicate rapid shipment availability

Free sizing and selection support from Virtual Engineer at parker.com/VirtualEngineer





⑩ Carriage Options

- 0** No external guide rail
- 6** ProLine PL25, PL32, PL50*
- E** PowerSlide PS25/25*
- F** PowerSlide PS25/35 or PS32/35*
- G** PowerSlide PS25/44 or PS32/44*
- H** PowerSlide PS50/60*
- I** PowerSlide PS50/76*
- M** Inversion Mounting**
- R** Clevis Mounting **

* Requires standard carriage (select order code "0" from ④). See Dimensions for additional information.

** Requires standard carriage (select order code "0" from ④). See Options & Accessories for Inversion Mounting and Clevis Mounting.

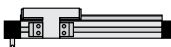
⑪ External Guide Rail Orientation

- 0**  Guide Rail (right side)
- 1**  Guide Rail (left side)

⑫ End Cap Mounting (see Options & Accessories)

- 0** No end cap mounting
- 1** 1 pair A1* (standard end cap) or C1** (block end cap)
- 2** 1 pair A2* (standard end cap) or C2** (block end cap)
- 3** 1 pair A3* (standard end cap) or C3** (block end cap)
- 4** 1 pair B1* (reinforced end cap) or C4** (block end cap)
- 5** 1 pair B4* (reinforced end cap)

* For size 25 and 32

** For size 50

⑬ Profile Mounting (see Options & Accessories)

- 0** No profile mounting
- 2** 1 pair D1 (with 2 internal threads)
- 5** 2 pair D1 (with 2 internal threads)
- 8** 3 pair D1 (with 2 internal threads)
- 1** 1 pair E1 (with 2 thru holes)
- 4** 2 pair E1 (with 2 thru holes)
- 7** 3 pair E1 (with 2 thru holes)
- 3** 1 pair MAE (with 3 thru holes)
- 6** 2 pair MAE (with 3 thru holes)
- 9** 3 pair MAE (with 3 thru holes)
- K** 1 pair E2 (with 2 thru holes)
- N** 2 pair E2 (with 2 thru holes)
- R** 3 pair E2 (with 2 thru holes)
- L** 1 pair E3 (with 2 thru holes)
- P** 2 pair E3 (with 2 thru holes)
- S** 3 pair E3 (with 2 thru holes)
- M** 1 pair E4 (with 2 thru holes)
- Q** 2 pair E4 (with 2 thru holes)
- T** 3 pair E4 (with 2 thru holes)

⑭ Magnetic Sensor Mounting*

- 0** No sensor mounting
- A** 1 pc. N.O., NPN, with M8 connector
- B** 2 pc. N.C., NPN, with M8 connector
- C** 1 pc. N.O., NPN, with M8 connector
2 pc. N.C., NPN, with M8 connector
- D** 1 pc. N.O., PNP, with M8 connector
- E** 2 pc. N.C., PNP, with M8 connector
- F** 1 pc. N.O., PNP, with M8 connector
2 pc. N.C., PNP, with M8 connector

* Extension cable with M8 connector and 5 m cable flying lead cable for Sensor with M8 plug can be ordered separately; use part number 003-2918-01

 Blue order codes indicate rapid shipment availability

Parker Hannifin Corporation • Electromechanical & Drives Division • Irwin, Pennsylvania • 800-358-9070 • www.parker.com/emn

OSPE..BV Fixed Belt-Driven Actuators

Actuators with Fixed Belt for Vertical Applications

- Fixed actuator head for low moving mass
- Integrated ball bearing guide for high bending moments
- Magnetic switch set for contactless position sensing
- Easy to install
- Low maintenance

Features

- High acceleration and speeds
- Drive Shaft versions with clamp shaft or plain shaft
- Power transmission by belt
- Moving axis profile
- Complete motor and control packages
- IP 20 rating

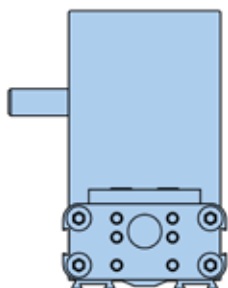

OSPE20BHD

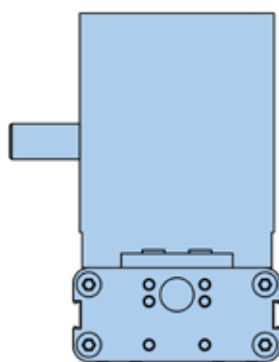

OSPE25BHD

	OSPE20BV	OSPE25BV
Maximum Travel (mm)	1,000	1,500
Maximum Payload F_z (N)	1,600	3,000
Maximum Acceleration (m/sec ²)	20	20

The OSPE..BV vertical fixed belt-driven actuator with integrated ball bearing guide is designed specifically for lifting loads in vertical orientation. The light weight design allows to use smaller motors with this actuator keeping the robust and aesthetically pleasing design of the OSPE series.

The compact and modular design allows the integration of the OSPE..BV in any machine layout, providing very little space, without sacrificing payload or thrust capacity.

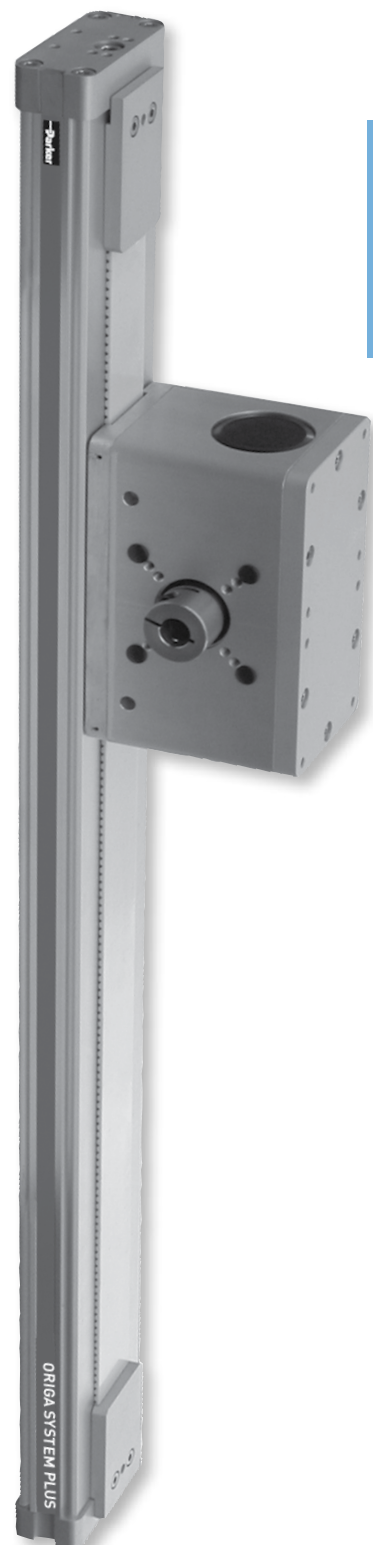

Belt Driven
Tables

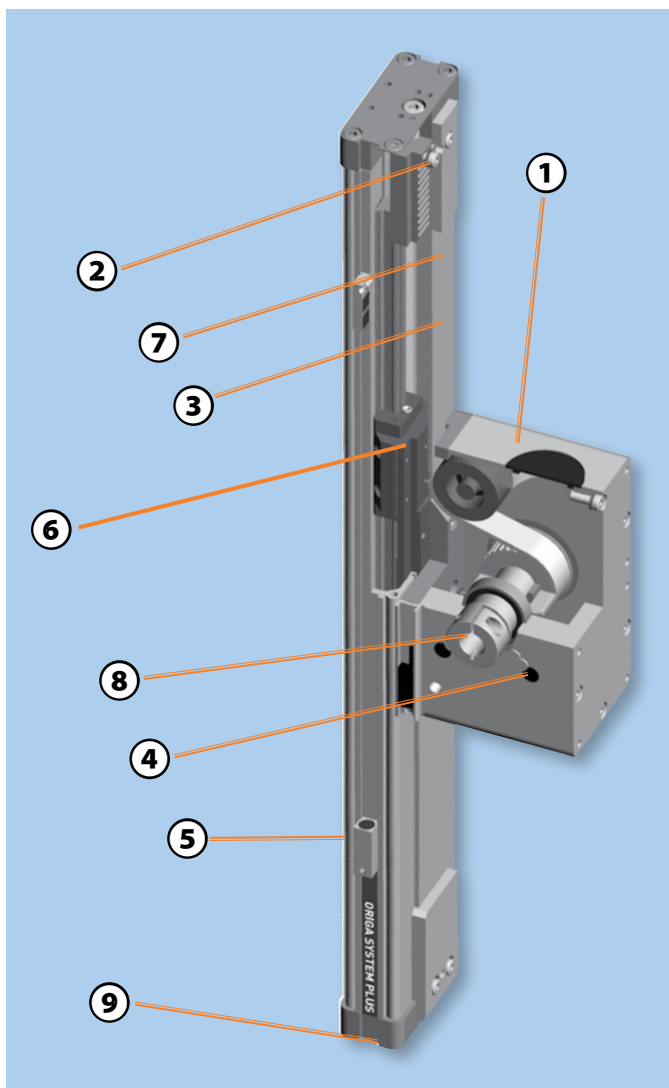

- ① **Carriage**
Low profile, high strength aluminum carriage with threaded holes for ease of mounting
- ② **Belt tensioning station**
Easy access for belt tension without removing the payload
- ③ **Corrosion resistant steel sealing band**
Magnetically fastened to the actuator body and provides sealing to IP54
- ④ **Lubrication access port**
Easy access maintenance allows for single point lubrication of bearing trucks at any point along travel
- ⑤ **Slotted profile**
With dovetail grooves for strength, actuator mounting, and mounting of sensor and other accessories
- ⑥ **Integrated ball bearing truck**
For high performance, high payload and moment load demands. (Optional roller wheels available.)
- ⑦ **Steel reinforced timing belt**
High thrust force transmission and long life
- ⑧ **Clamp shaft**
Optimal, zero-backlash coupling for gearhead and motor
- ⑨ **End housing mounting**
Threaded mounting holes allow for a multitude of mounting options

Drive Shaft Options

- Drive shaft with clamp shaft
- Drive shaft with both clamp and plain shaft
- Drive shaft with plain shaft
- Drive shaft with double plain shaft for parallel operation of two Z-axes with an intermediate drive shaft

Actuator Head Orientation

All OSPE..BV actuator heads are standard with an integrated ball bearing guide and are available with either left or right side gearhead/motor mounting.

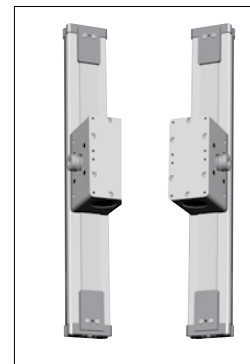

Drive Head Options

Standard or tandem with additional actuator head and two additional carriers for higher bending moments.

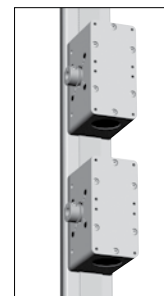

Multi-axis Systems

A wide range of adapter plates and intermediate drive shafts simplifies engineering and installation. Please consult factory for your individual system design.

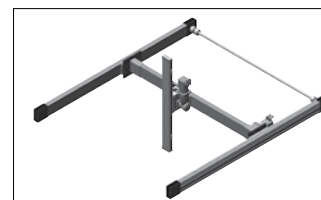

Magnetic Switches Set

Magnetic switches with connector, mounting rail and magnets for contactless sensing of the end positions. Cable (suitable for cable chain) can be ordered separately in 5 m, 10 m or 15 m length.

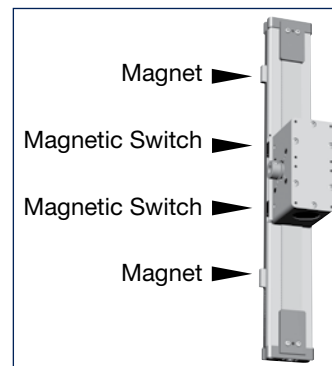

Options and Accessories

Information on all OSPE..BV Series options is detailed in Options & Accessories. Simply select all the options needed to solve your application requirements, then order with the actuator using convenient order codes (see Ordering Information). To order an option separately as an upgrade to an existing system or as a replacement part, use the individual option part numbers provided.

SPECIFICATIONS



OSPE..BV Performance Data

Actuator Size			OSPE20BV	OSPE25BV
Travel Distance per Revolution	S_{lin}	mm	108	160
Linear Speed (Max)	v_{max}	m/s	3	5
Acceleration (Max)	a_{max}	m/s ²	20	20
Repeatability		μm	± 50	± 50
Order Stroke (Max)		mm	1,000	1,500
Recommended Permissible Mass (Max)		kg	10	20
Thrust Force (Max)	F_{Amax}	N	650	1,430
		lbs	146	321
Torque on Drive Shaft (Max)	M_{Amax}	Nm	12	38
		in-lb	104	333
Torque* – No Load	RMS	M_0	Nm	0.9
			in-lb	8
	Peak	M_0	Nm	1.1
			in-lb	10
Load** (Max)	F_Y	N	1,600	
		lbs	360	
	F_Z	N	1,600	
		lbs	360	
Bending Moment Load* (Max)	M_X	Nm	20	
		in-lb	177	
	M_Y	Nm	100	
		in-lb	885	
	M_Z	Nm	100	
		in-lb	885	
Thrust Force (Max) FA	N @ Specified Speed	<1 m/s	650	
		<2 m/s	605	
		<3 m/s	450	
		<4 m/s	—	
		<5 m/s	—	
	N @ Specified Stroke	<1 m	650	
		<2 m	605	
			1,367	
Torque (Max) MA	Nm @ Specified Speed	<1 m/s	12	
		<2 m/s	11	
		<3 m/s	8	
		<4 m/s	—	
		<5 m/s	—	
	Nm @ Specified Stroke	<1 m	12	
		<2 m	11	
			36	
Inertia				
@ Zero Stroke	J_0	kgmm ²	486	1,695
Per Meter of Stroke	J_{OS}	kgmm ² /m	1,144	2,668
Per 1 kg Moved Mass	J_m	kgmm ² /kg	296	649
Weight				
@ Zero Stroke	m_0	kg	2.8	6.2
Per Meter of Stroke	m_{OS}	kg/m	4.5	7.8
Moved Mass of Carriage	m_C	kg	1.5	2.6
Ambient Temperature Range		°C	-30 to +80	
IP Rating			IP 20	

* For Tandem option double the values listed
 ** Load and bending moment based on 8000 km performance

Belt Driven Tables

DIMENSIONS

OSPE..BV Order Stroke Dimensions

Standard Drive Head

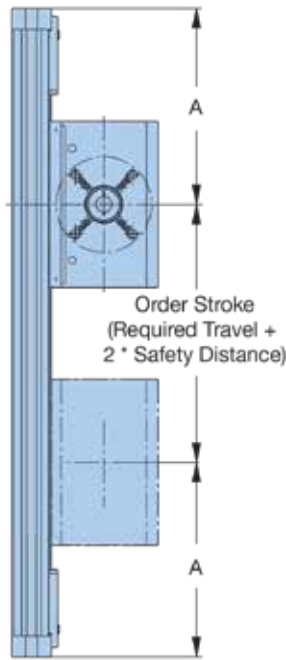

Tandem Drive Head

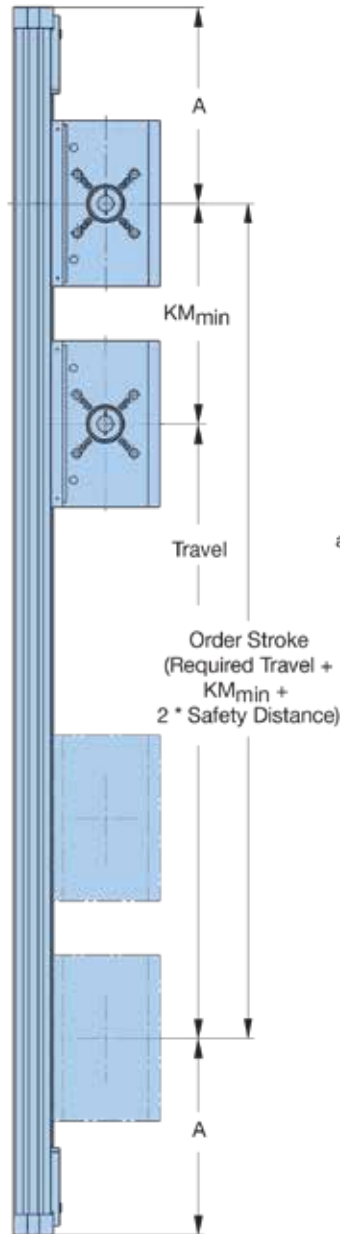

Actuator Size	OSPE20BV	OSPE25BV
A	148	210
KM_{min}	155	225
KM_{rec}	225	275

KM_{min} is the minimum distance between two drive heads possible.
 KM_{rec} is the recommended distance between two drive heads for optimal performance.

Magnetic Switch Dimensions

The magnetic switch set provides contactless sensing of the end positions. The mounting rail and magnetic switches are mounted on the actuator drive head and the magnets are mounted in the dovetail slot on the profile.

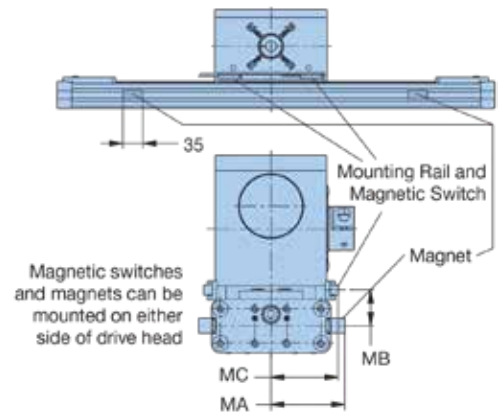

Dimension (mm)

	OSPE20BV	OSPE25BV
MA	46.0	56.0
MB	23.7	26.0
MC	42.3	51.0

Order Stroke Safety Distance:

The mechanical end position should not be used as a mechanical end stop, thus an additional Safety Distance at both ends of travel must be incorporated into the Order Stroke.

The safety distance for servo-driven systems is equivalent to the travel distance per one revolution of the drive shaft.

AC motor-driven systems with VFDs require a larger safety distance than servo systems. For further information and design assistance, please consult factory.

Base Unit Dimensions

Drive Shaft Versions:

- Clamp shaft • Plain Shaft • Clamp Shaft with Plain Shaft • Double Plain Shaft

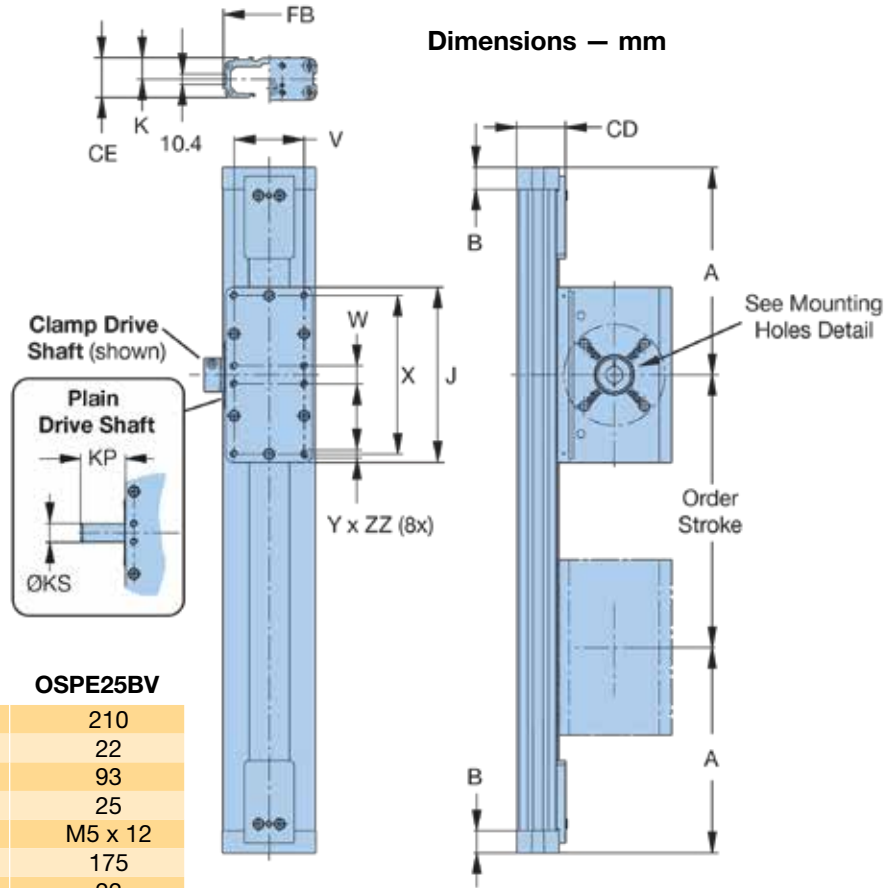
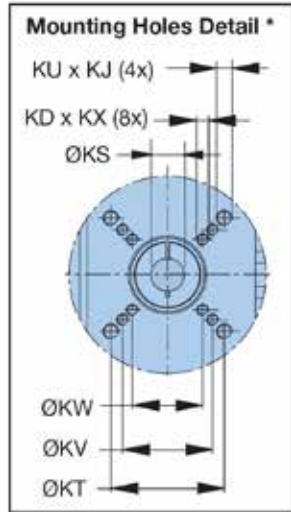

Actuator Size	OSPE20BV	OSPE25BV
A	148	210
B	22	22
C	93	93
E	25	25
G x H	M5 x 12	M5 x 12
J	139	175
K	21	22
M	102	134
S	68	87
V	51	70
W	40	18
X	120	158
Y x ZZ	M6 x 10	M6 x 10
CD	40	49
CE	34	42
CF	123	155
EC	59	72
EF	21	27
FB	73	92
FH	36	40
KD x KX	—	M6 x 16
KF	61	76
KN	27	34
KO	16	22
KP	29	32
KS	12 ^{H7}	16 ^{H7}
KT	47	58
KU x KJ	M6 x 10	M8 x 16
KV	36	46
KW	—	36

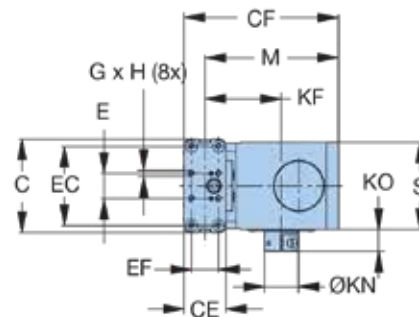

* Mounting holes for motor flange or external planetary gearhead. Drive shaft and motor mounting holes can be located on either side of carriage (see Ordering Information for drive shaft options).

Free sizing and selection support
from Virtual Engineer at
parker.com/VirtualEngineer







ORDERING INFORMATION OSPE..BV

Select an order code from each of the numbered fields to create a complete OSPE..BV model order number. Include hyphens and non-selective characters as shown in example below.

1
 2
 3
 4
 5
 6
 7
 8
 9

Order Number Example: OSPE 20 - 7 0 0 02 - 00000 - P 00 0 0 0

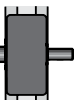
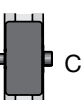
- ① **Series**
OSPE Origa System Plus Electromechanical
- ② **Bore Size**
20 73 mm W x 123.3 mm H
25 93 mm W x 154.5 mm H
- ③ **Drive Train**
7 Vertical Fixed Belt-Driven Actuator w/Integrated Ball Bearing Guide
- ④ **Carriage**
0 Standard
1 Tandem (two drive heads for higher actuator stiffness)
- ⑤ **Drive Shaft Configuration and Orientation ⁽¹⁾**

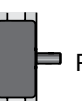
02		Clamp shaft* (left)
04		Clamp shaft* (right)
03		Clamp shaft* (left) with plain shaft for use with intermediate drive shaft for parallel actuator system
05		Clamp shaft* (right) with plain shaft for use with intermediate drive shaft for parallel actuator system
0A		Plain shaft idler unit** (left) for parallel actuator system
0B		Plain shaft idler unit** (right) for parallel actuator system

* Consult factory for all gearhead and motor mounting options
 ** Only available with order code 00 "No gearhead mounting kit or motor option" (item 8)

- ⑥ **Order Stroke***
00000 5-digit input (in mm)*
* Maximum standard stroke: OSPE20BV = 1000 mm; OSPE25BV = 1500 mm. For example, to OSPE..V with maximum order stroke, specify 01500. Longer strokes available upon request. Consult factory.
- ⑦ **Hardware and Cover Strip**
P Standard hardware with Parker gold cover strip
- ⑧ **Gearhead/Motor Mounting Options**
00 No gearhead mounting kit or motor option
xx Consult factory for all gGearhead and motor mounting options
- ⑨ **Magnetic Sensor Mounting**
0 No sensor mounting
B 2 pc. N.C., NPN, with M8 connector
E 2 pc. N.C., PNP, with M8 connector
* Extension cable with M8 plug and 5 m cable flying lead cable for Sensor with M8 connector can be ordered separately; use part number 003-2918-01

⁽¹⁾ Drive Shaft Orientation
 Drive shaft orientation is determined by viewing the actuator facing the drive head with the belt tensioning end facing up and the end cap for mounting the load facing down.

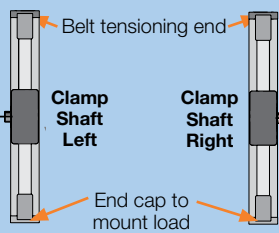

Note:
 Special drive shafts are available – consult factory.

The LCR Series

Miniature Belt-Driven
Designs with Maximum
Versatility

Belt Driven
Tables



- Miniature footprint – 30 x 40 mm cross-section
- Internal square rail or glider bearing design
- 100% duty cycle
- IP30 stainless steel strip seal
- Low noise 2 and 10 mm leadscrew or long travel belt drive
- Travel lengths to 1000 mm
- Attractive black anodize finish

Features

- Extruded aluminum body incorporates dovetail mounting, T-slots and belt return
- Toe clamp mounting for easy installation
- Dowel pin holes in the LCR30 carriage for repeatable mounting
- Multiple motor mount options accommodate NEMA 11,17 and 23 steppers and NEMA 16 servo motors
- Flush-mounted NPN, PNP, N.O. or N.C. fully adjustable limit sensors maximize flexibility and minimize footprint impact
- Screw-driven version has an optional parallel motor mount for space constrained applications

	LCR30
Maximum Travel (mm)	600
Maximum Payload (N)	500
Maximum Acceleration (m/s ²)	20

*Do not exceed allowable axial and moment loading.

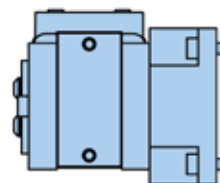

LCR30

For OEMs looking to automate light payloads, the new LCR (Light Capacity Rodless) linear positioner family provides the smallest form factor with unmatched, easy-to-use flexibility.

With any “build-it-yourself” positioner, all the parts required to build a linear motion axis from scratch must be ordered, tracked, received, inventoried, assembled and tested. In contrast, the LCR Series is a completely pre-engineered, pre-tested, ready-to-use positioner solution,

which allows OEMs to significantly reduce their time to market with minimized design, procurement, manufacturing, assembly and qualification time or effort.

Based on the proven life science track record of Parker’s MX80 and LP28 Series, the LCR was developed specifically to provide a high-quality, easy-to-use, off-the-shelf linear actuator.

LCR solutions are ideal for Maldi-plate and micro-titer tray automation. Rated for 100%

duty cycle, the LCR offers smooth, quiet motion ideal for keeping instrument noise to a minimum. With selectable travel lengths up to 1000 mm and payloads up to 100 N (25 lbs), the ability to automate laboratory instruments has never been easier.

Bottom Line Impact

The LCR’s proven pre-engineered design will significantly reduce your instrument time to market and improve your ROI.

Tailored to Meet Every Requirement

The LCR is an easy-to-configure off-the-shelf solution with a virtually unlimited array of standard configurations available.

If your application demands a special design, Parker takes the next step and customizes the product to meet your required specification. Common modifications include:

- **Clean room components**
- **Special tool plates**
- **Mounts for 3rd party motors**
- **Single or parallel acting electric grippers**
- **Maximum height or length modifications for space constraints**
- **And much more**

Whether you need blue anodize or a design with a custom carriage for larger than standard payloads, or anything else, Parker excels at application solutions and will modify the LCR to fit your specific needs.

Please call us at 800-245-6903 to discuss your requirements.



Ideal for High-Volume, Light-Capacity, Electrically-Controlled Motion

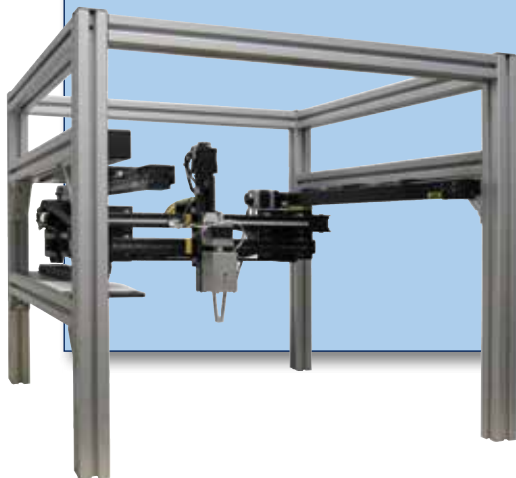

Life science applications:

- **Mass spectroscopy**
- **Course microscopy**
- **Analytical instruments**
- **Laboratory automation**
- **Micro titer automation**
- **MALDI plate automation**
- **Liquid handling**
- **Syringe pumps**

General-purpose applications:

- **Point-of-purchase kiosks**
- **Adjustable guide widths for conveyor lines**
- **Storage and retrieval**
- **Part shuttling**
- **Light payload automation conversion from rodless pneumatics to electric**
- **General automation for any ≤ 25 lb payload with basic repeatability requirements**



All LCR series actuators are compliant to RoHS and CE directives.

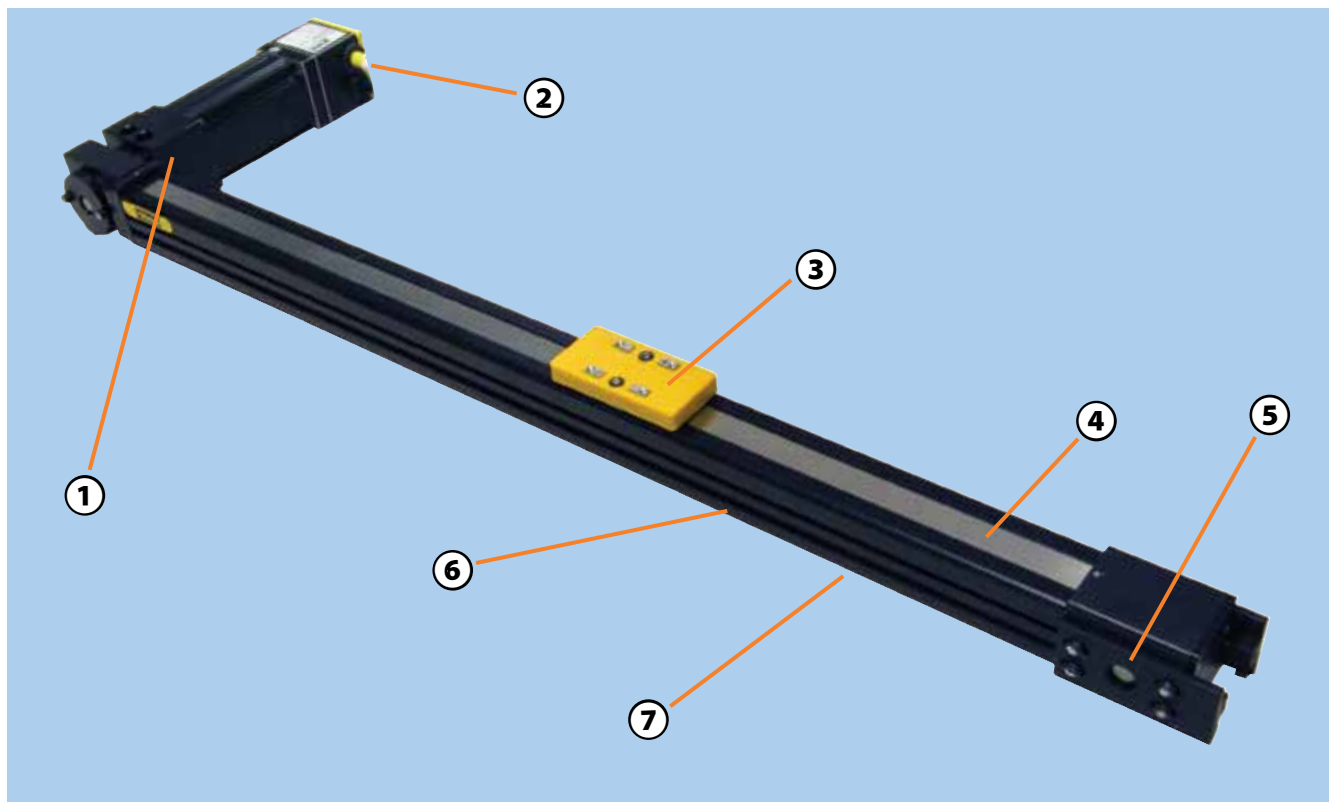

- ① **Motor Mounting Options**
The most motor mounting options standard with more options easily available
- ② **Encoder options**
For position verification and position maintenance
- ③ **Carriage mounting surface**
Machined aluminum carriage mounting surface with locating holes
- ④ **Stainless steel sealing strip**
Best in class bearing and drive train protection
- ⑤ **Easily adjustable belt tension system**
Reduces maintainance and down time
- ⑥ **Minimal instrument/machine size**
Including flush mount limit sensors
- ⑦ **Profile size**
Provides high rigidity for minimal deflection along with "T" and dovetail slots

Stepper drive option
Simple and powerful plug and spin P2™ stepper drive option



Rugged internal square rail
Re-circulating bearing or quiet glider bearing for lighter payload needs



Quick and easy mounting options
With toe clamps or standard multi-axis connection kits



Flexible drive train options
With multiple screw leads for high thrust or reinforced belt drive for highest speeds



Parallel motor mounts available



Metric and Imperial graduated scales
integral to the LCR body frame are among the many custom modifications available.



The P2™ Drive

An OEM-Friendly Design...

The P2 Completes the LCR as an Easy-to-Use Motion Solution

Pairing the LCR with the P2™ drive, instrument builders eliminate another costly design component and complete their motion package with a single-vendor, easy-to-use solution.

The P2 drive is only 1" x 1" x 3" in size, but packs 2 A of current at 24 VDC to provide superior power density for simple step and direction motion.

The Parker P2 Stepper Drive is a complete step and direction indexer for hybrid step motors. The P2 drive operates stepper motors in full, half, quarter, and sixteenth step modes with an output drive capacity up to 24 VDC and 2.0 amps.



Key Design Advantages

- On board eyelets allow OEMs to measure output current and to set all drives equally
- Two potentiometers allow for easy adjustment of standby and run current
- No programming
- No code to learn
- Robust, high quality product with 100% pre-ship testing

Key Design Features

- Supply voltage 12 to 24 VDC
- 2.0 amps max motor output current
- Adjustable run current and standby current
- Single or differential ended inputs
- Enable, step and direction inputs voltages up to ± 14 VDC (low/high input): < 0.8 V Low, > 2 V High
- 1.0 μ s minimum step pulse width
- 1.0 μ s minimum step pulse low time
- 0 to 40°C operating temperature with natural convection
- 5 to 95% relative humidity, non-condensing
- Optional DIN rail mount
- Resolutions of 200, 400, 800 and 3200 steps/rev (with 1.8° step motor)
- Small package (80 mm x 25 mm x 25 mm)
- RoHS compliant

P2 saves a lot more than space...



The P2 Series offers added value to customers who traditionally specify board level drives or design their own drives in house.

① Free-up engineering, procurement, quality, and assembly resources in house. The P2 Series reduces the instrument/machine design time by utilizing an off-the-shelf solution.

The result: faster time to market for new products, allowing customers to focus on core competency.

② The P2 also reduces procurement complexity by reducing the need to chase multiple vendors versus a do-it-yourself drive design.

The result: better return on investment.

③ The P2 Series provides the customer added flexibility to mount the enclosed, protected drive directly onto a motion axis such as the Parker LCR Series, or DIN rail mount in a convenient location.

The result: a well protected, robust drive with quick and easy installation for an easy out-of-box user experience.

LCR Series Performance Specifications

Addressing applications which involve positioning of smaller payloads within a very small space envelope, the LCR30 is the ideal solution for OEM instrument manufacturers. The LCR30 offers a reduced overall cost of ownership and a complete solution including amplifier/drive, motor, actuator, bearings, seals, and limit sensors.



Belt Driven
Tables

LCR Belt-Driven Performance by Profile Size

Specification	Units	LCR30			
		S (Square Rail)	B (Bushing)		
Grade					
Bidirectional Repeatability	mm	± 0.2	± 0.5		
Duty Cycle	%	100	100		
Max. Acceleration*	m/s ²	20	20		
Max. Linear Speed	mm/s	870	870		
Normal Load	N	90	45		
Moment Load					
Roll	Nm	2.6	0.3		
Yaw				6.5	0.8
Pitch					
Max. Axial Load	N	45	45		
Linear Travel/Rev	mm	58.0	58.0		
Breakaway Torque	mNm	85.0	85.0		
Coefficient of Friction		0.02	0.10		
Carriage Weight	N	0.5	0.5		
Base Moment of Inertia					
I_{xx}	mm ⁴	39,778	36,162		
I_{yy}				46,273	42,066

*Do not exceed allowable axial and moment loading.

Model	LCR30
Width x Height (mm)	30 x 40
Repeatability (±mm)	0.2
Max. Normal Load¹ (N)	90
Max. Axial Load (N)	45
Max. Speed² (mm/s)	870
Max. Travel Length (mm)	1000
Screw Lead Options (mm/rev)	—

¹ Specifications for square rail design, bushing version reduces normal load to 50% value.

² Specifications for fast screw lead, the fine screw lead will reduce maximum speed.

LCR Belt-Driven Performance by Travel Length (no load)

Travel	LCR30		
	Table Weight (M23)	Total Inertia Reflected (kg-m ²)	
		No Load	2.5 kg Load
25	1.23	3.111 ⁻⁶	2.161 ⁻⁴
50	1.27	3.145 ⁻⁶	2.161 ⁻⁴
75	1.30	3.189 ⁻⁶	2.162 ⁻⁴
100	1.34	3.232 ⁻⁶	2.162 ⁻⁴
125	1.37	3.276 ⁻⁶	2.163 ⁻⁴
150	1.41	3.319 ⁻⁶	2.163 ⁻⁴
175	1.44	3.363 ⁻⁶	2.163 ⁻⁴
200	1.48	3.406 ⁻⁶	2.164 ⁻⁴
225	1.52	3.500 ⁻⁶	2.164 ⁻⁴
250	1.55	3.493 ⁻⁶	2.165 ⁻⁴
275	1.59	3.536 ⁻⁶	2.165 ⁻⁴
300	1.62	3.580 ⁻⁶	2.166 ⁻⁴
325	1.66	3.623 ⁻⁶	2.166 ⁻⁴
350	1.69	3.667 ⁻⁶	2.166 ⁻⁴
375	1.73	3.710 ⁻⁶	2.167 ⁻⁴
400	1.76	3.754 ⁻⁶	2.167 ⁻⁴
425	1.80	3.797 ⁻⁶	2.168 ⁻⁴
450	1.83	3.841 ⁻⁶	2.168 ⁻⁴
475	1.87	3.884 ⁻⁶	2.169 ⁻⁴
500	1.90	3.927 ⁻⁶	2.169 ⁻⁴
525	1.94	3.980 ⁻⁶	2.170 ⁻⁴
550	1.97	4.014 ⁻⁶	2.170 ⁻⁴
575	2.01	4.058 ⁻⁶	2.170 ⁻⁴
600	2.04	4.101 ⁻⁶	2.171 ⁻⁴
625	2.08	4.145 ⁻⁶	2.171 ⁻⁴
650	2.11	4.188 ⁻⁶	2.172 ⁻⁴
675	2.15	4.232 ⁻⁶	2.172 ⁻⁴
700	2.18	4.275 ⁻⁶	2.173 ⁻⁴
725	2.22	4.319 ⁻⁶	2.173 ⁻⁴
750	2.25	4.362 ⁻⁶	2.173 ⁻⁴
775	2.29	4.405 ⁻⁶	2.174 ⁻⁴
800	2.32	4.449 ⁻⁶	2.174 ⁻⁴
825	2.36	4.492 ⁻⁶	2.175 ⁻⁴
850	2.40	4.536 ⁻⁶	2.175 ⁻⁴
875	2.43	4.579 ⁻⁶	2.176 ⁻⁴
900	2.47	4.623 ⁻⁶	2.176 ⁻⁴
925	2.50	4.666 ⁻⁶	2.176 ⁻⁴
950	2.54	4.710 ⁻⁶	2.177 ⁻⁴
975	2.57	4.753 ⁻⁶	2.177 ⁻⁴
1000	2.61	4.796 ⁻⁶	2.178 ⁻⁴

Linear Speed-Force Performance

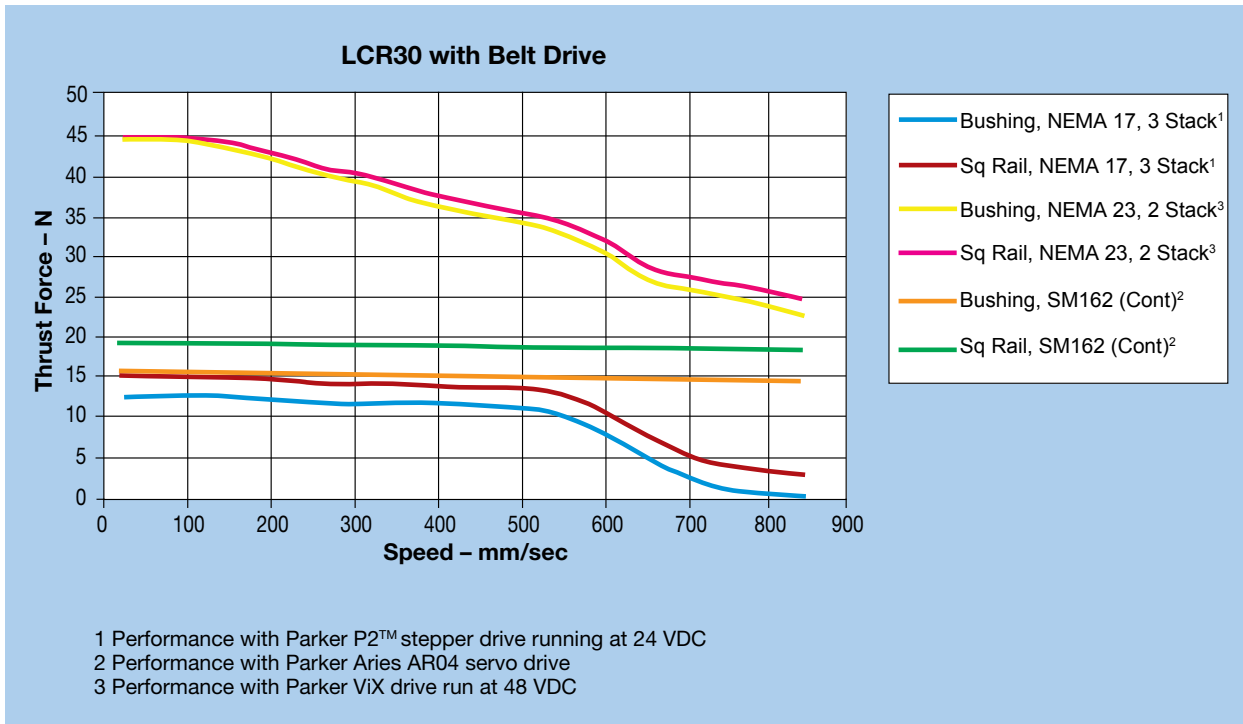

Belt Driven Tables

DIMENSIONS

LCR30 Belt-Driven

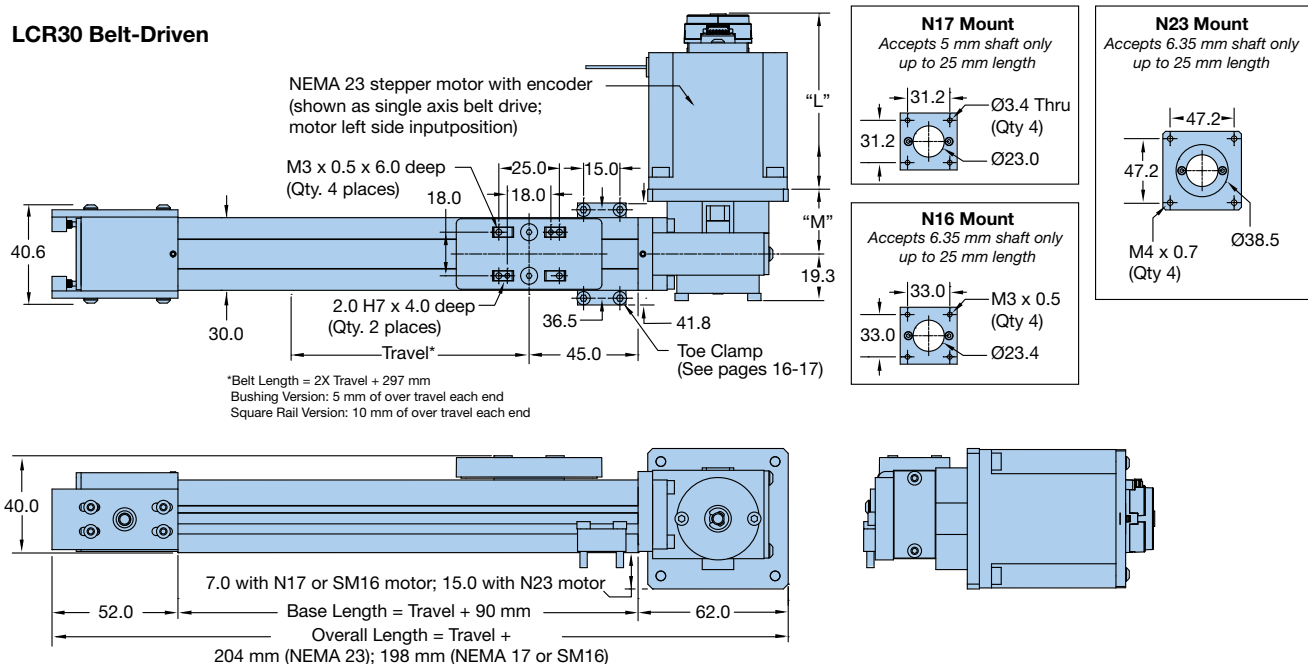

Motor Option	Encoder Option	M	L	Description
M23	E0	44.3	73.0	LV232 NEMA 23 Stepper Motor
M23	E2	44.3	73.0	LV232 NEMA 17 Stepper Motor with 500 Count Encoder
M17	E0	44.8	58.2	NEMA 17 Stepper Motor
M17	E2	44.8	58.2	NEMA 17 Stepper Motor with 500 Count Encoder
M16	E0	46.3	137.0	SM16 Servo Motor Mount with SM162-AE-N10N

Idler Unit – Square Rail Models only

LCR30 Idler

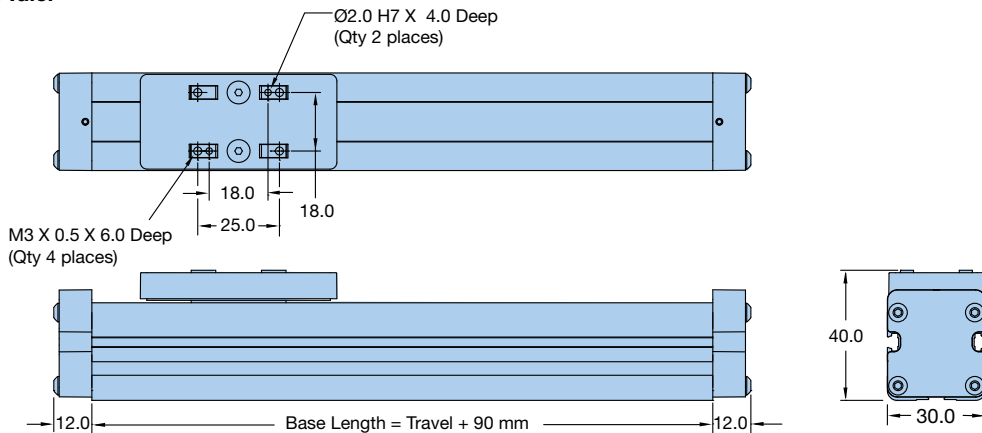

P2™ Stepper Drive

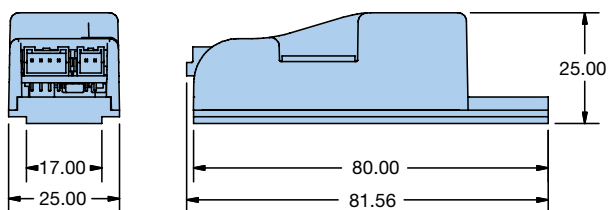

P2 Pin Out Diagram

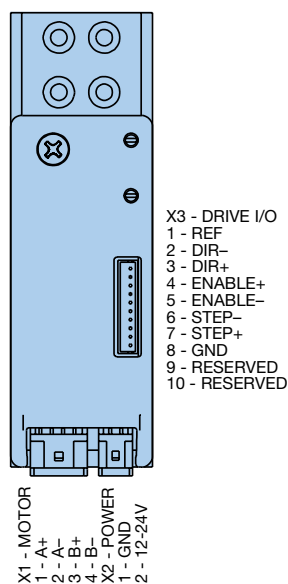

Free sizing and selection support
from Virtual Engineer at
parker.com/VirtualEngineer



OPTIONS & ACCESSORIES

X-Y and X-Z Brackets

Dimensions – mm

X-Y Bracket for LCR30 Screw-Driven Units

#002-3272-01

(includes four toe clamps with fasteners)

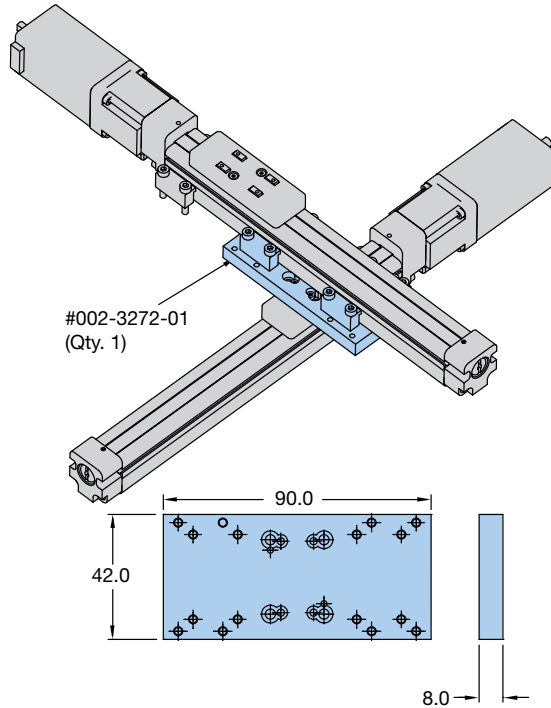

X-Z Bracket for LCR30 (All Units)

#002-3273-01

(includes four toe clamps with fasteners)

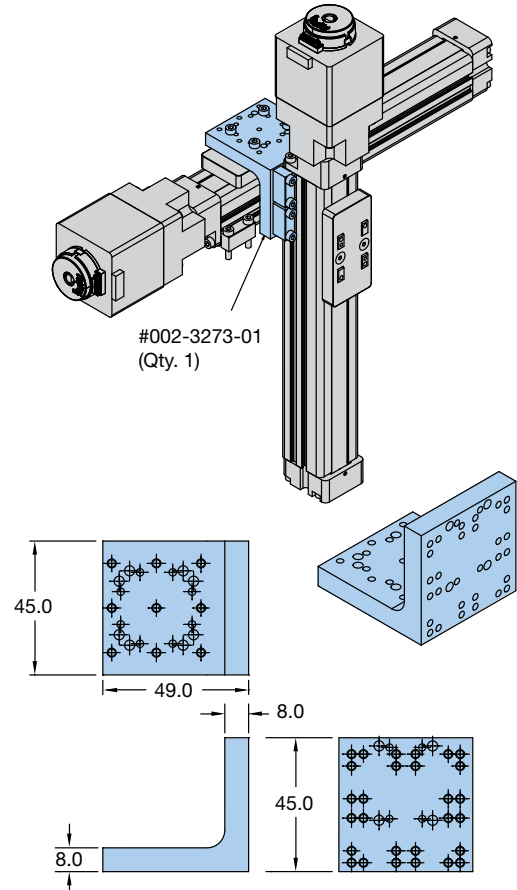

X-Y Bracket for LCR30 Belt-Driven Units

#002-3274-01

(includes two toe clamps with fasteners)

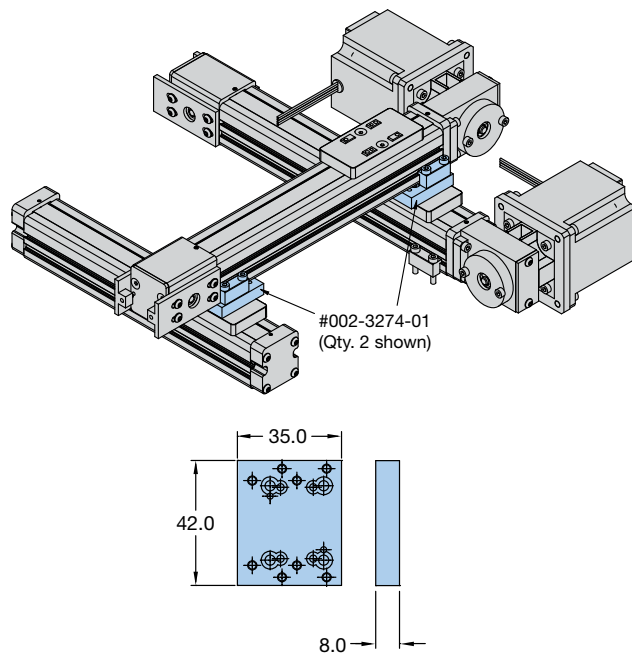

Toe Clamp Assembly #002-3233-01

(includes toe clamp and two socket head fasteners)

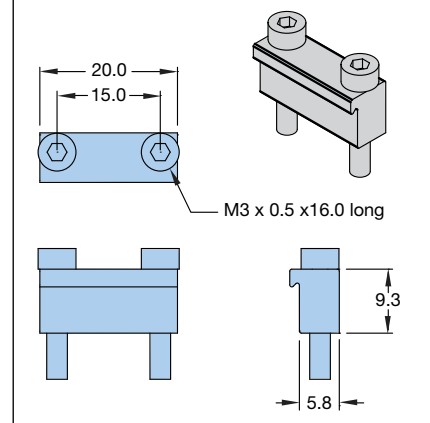

Belt Driven
Tables

Toe Clamps



Toe clamp kits include socket head fasteners to mount clamp.

Part Number	Quantity
002-3233-01	1
002-3233-04	4
002-3233-100	100

Encoder

When using stepper motors, positional feedback is readily available with the optional rotary encoder. The robust magnetic encoder withstands vibration and provides easy in-position confirmation.



Encoder

Part Number	Counts/rev	Bore
003-4590-01	400	4 mm
003-4590-02	400	5 mm
003-4590-03	500	4 mm
003-4590-04	500	5 mm
003-4590-05	400	6.35 mm
003-4590-06	500	6.35 mm

Encoder Cable (6-pin differential)

006-2398-1.0	1m high flex with flying leads
006-2398-3.0	3m high flex with flying leads

Wiring Connection

Pin	Wire	Function
1	White	Ground
2	Green	A+
3	Yellow	A-
4	Brown	+5 VDC
5	Blue	B+
6	Red	B-
7	Pink	Not used
8	Gray	Not used

End-of-Travel Limit Sensors

Limit sensors offer home and end of travel protection in a flush mount design that minimizes the overall width of the LCR series. The limit sensors are available standard as NPN or PNP with normally open or normally closed designs.

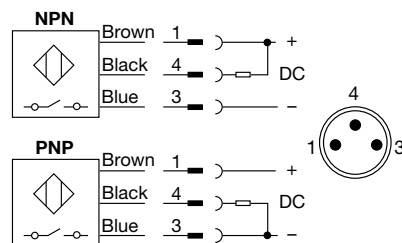

Specifications

- Operating Voltage:** 10-30 VDC
- Repeatability:** $\leq \pm 0.1$ mm
- EMC:** EN 60 947-5-2
- Short circuit protections:** Yes
- Reverse Polarity Protection:** Yes
- Enclosure Rating:** IP 67
- Operating Temperature Range:** -25° to 75° C (-13° to 167° F)

Wiring Connection

Pin	Wire	Function
1	Brown	+ VDC
4	Black	NO
3	Blue	- VDC

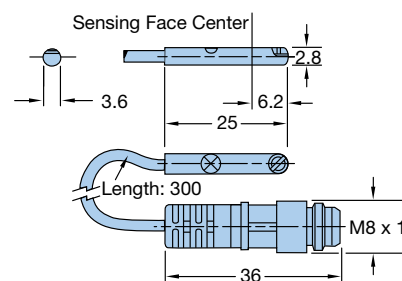
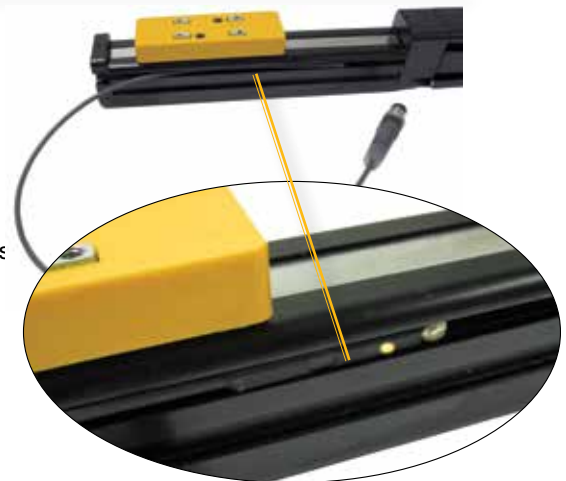

Part Number	Logic	Cabling
P8SAMQFAZ	PNP N.C.	3 meter flying leads
P8SAMQCHZ	PNP N.C.	0.3 meter with M8
P8SAMMFAZ	NPN N.C.	3 meter flying leads
P8SAMMCHZ	NPN N.C.	0.3 meter with M8
P8SAMPFAZ	PNP N.O.	3 meter flying leads
P8SAMPCHZ	PNP N.O.	0.3 meter with M8
P8SAMNFAZ	NPN N.O.	3 meter flying leads
P8SAMNCHZ	NPN N.O.	0.3 meter with M8
003-2918-01	All cabling	5 meter extension cable for M8 connections

ORDERING INFORMATION

LCR

Fill in an order code from each of the numbered fields to create a complete model order code.

	①	②	③	④	⑤	⑥	⑦	⑧	⑨	⑩	⑪
Order Example:	LCR	30	LN10	0075	S	S	A	N08	E0	L1	A1

① **Series**

LCR Series

② **Size (width in mm)**

30 30 mm wide profile

③ **Drive Train**

IDLR Idler unit; no drive mechanism

LN02 2 mm leadscrew with in-line motor mount

LN10 10 mm leadscrew with in-line motor mount (available with LCR30 size only)

BLT0 Single axis belt drive

④ **Travel Length (mm)**

xxxx 25 mm increments of travel
 LCR30 Screw-Driven: 25 to 600 mm
 LCR30 Belt-Driven: 25 to 1000 mm

⑤ **Bearing Type**

S Square rail bearing

B Glider bushing bearing

⑥ **Environmental Protection**

S Strip seal protection (standard)

⑦ **Motor Mount Position**

I Inline

A Parallel mount, Position "A"*

B Parallel mount, Position "B"*

C Parallel mount, Position "C"*

R Belt drive, motor right

L Belt drive, motor left

— No motor

*Not available with BLT0 drive train options.

⑧ **Motor**

N00 No motor

N11 NEMA 11 motor mount ²⁾

N16 SM16 motor mount ³⁾

N17 NEMA 17 motor mount ³⁾

N23 NEMA 23 motor mount ³⁾

M11 NEMA 11 stepper motor ²⁾

M16 SM162AE-N10N servo motor ³⁾

M17 NEMA 17 stepper motor ³⁾

M23 NEMA 23 stepper motor ⁴⁾

²⁾ Not available on BLT0 belt drive version

⁴⁾ Only available on BLT0 belt drive version

⑨ **Motor Encoder Option**

E0 No encoder

E2 500 line encoder*

*Only available with M11, M17, and M23 motor options

⑩ **Home & End-of-Travel**

L0 No home or limit sensors

L1 3 NPN sensors (1 N.O.; 2 N.C.)

L2 1 NPN sensor (N.O.)

L3 3 PNP sensors (1 N.O.; 2 N.C.)

L4 1 PNP sensor (N.O.)

L5 3 NPN sensors (2 N.O.; 1 N.C.)

L6 1 NPN sensor (N.C.)

L7 3 PNP sensors (2 N.O.; 1 N.C.)

L8 1 PNP sensor (N.C.)

⑪ **Stepper Drive/Amplifier**

A0 No P2 Drive

A1 P2 Stepper Drive/Amplifier

A2 P2 Stepper Drive/Amplifier with 1 meter cable set* (flying leads)

A3 P2 Stepper Drive/Amplifier with 1 meter cable set* to ACR

A4 P2 Stepper Drive/Amplifier with 1 meter cable set* to 6K

*For longer cable needs please order the A1 option and order cables separately

Free sizing and selection support
 from Virtual Engineer at
parker.com/VirtualEngineer



Ordering Information

Order Example:

① ② ③ ④ ⑤ ⑥ ⑦
P2 D 2 SD E0 FL1 K0

- ① **Series**
P2 Series
- ② **Intelligence**
D Stepper drive
- ③ **Power Level**
2 2 amps max
- ④ **Communication**
SD Step and direction input
- ⑤ **Feedback**
E0 No encoder
- ⑥ **Cable Set**
FL0 No cable set
FL1
FL3
AC1 See chart at left
AC3
6K1
6K3
- ⑦ **Mounting Kit**
K0 Standard plate mounting kit included
K1 DIN Rail Mounting Kit



P2 Options and Accessories

Part Number	Order Code	Description
006-2342-1.0	—	Power Cable – 1 m , High Flex
006-2342-3.0	—	Power Cable – 3 m , High Flex
006-2343-1.0	—	6K Control Cable – 1 m, High Flex
006-2343-3.0	—	6K Control Cable – 3 m, High Flex
006-2344-1.0	—	ACR Control Cable – 1 m, High Flex
006-2344-3.0	—	ACR Control Cable – 3 m, High Flex
006-2345-1.0	—	Control Cable – Flying Leads – 1 m, High Flex
006-2345-3.0	—	Control Cable – Flying Leads – 3 m, High Flex
006-2357-1.0	—	Motor Power Extension – 1 m
006-2357-3.0	—	Motor Power Extension – 3 m
002-3296-1.0	FL1	1 m Flying Lead Cable Set (contains power and communications cable from above list)
002-3296-3.0	FL3	3 m Flying Lead Cable Set (power and communications cable from above list)
002-3297-1.0	AC1	1 m Cable Set to ACR (power and communications cable from above list)
002-3297-3.0	AC3	3 m Cable Set to ACR (power and communications cable from above list)
002-3298-1.0	6K1	1 m Cable Set to 6K (power and communications cable from above list)
002-3298-3.0	6K3	3 m Cable Set to 6K (power and communications cable from above list)
002-3294-01	—	DIN Rail Mounting Kit (DIN clip and screw)
002-3295-01	—	Mounting kit to attach P2™ to LCR

HPLA Series Belt Driven Linear Modules

Belt-Drive Actuators for High Thrust, Long Stroke Applications

- Strong – steel roller bearing option for highest load capacity – 1530 kg
- Rugged construction for heavy duty applications
- Thrust force capacity to 5455 N
- Standard travel up to 9 meters
- Velocity up to 5 meters/sec.
- Positional repeatability of ± 0.2 mm
- Timing belt and pulley drive mechanism for fast, accurate positioning



Belt Driven
Tables

Proven Technology

- Direct mounting for planetary gear reducers – eliminating complexity of additional machined parts or couplings
- Adjustable “end of travel” limit switches and “Home” position sensor
- Cable carrier systems
- Performance matched Parker servo systems
- Structural components for vertical and multi-axis mounting
- Toe clamps and hardware for fast/easy mounting
- External bumper option
- Link shafts and support bearing for dual unit axes
- Splice plates for extending travels beyond length available in a single profile

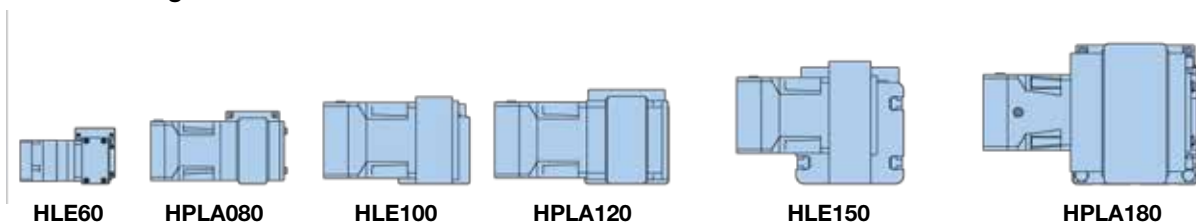

	HLE60	HPLA80	HLE100	HPLA120	HLE150	HPLA180
Maximum Travel (mm)	4,000	5,540	6,200	9,470	7,900	9,240
Maximum Payload (N)	353	1,304	1,549	2,598	3,402	4,501
Maximum Acceleration (m/s²)	10	10	10	10	10	10

*Do not exceed allowable axial and moment loading.

The HPLA is a rugged “next generation” linear module that offers high speed, high acceleration, and long travel, combined with stiff, rigid construction characteristics. It is ideally suited as a single axis product or as a component for high speed multi-axis gantries.

The HPLA carriage is rigidly supported on three sides by heavy duty roller bearings, housed in a

rugged aluminum housing. The bearing wheels are pre-loaded via eccentric bushings to eliminate play in the system, and are strategically located to evenly distribute the load across the length of the carriage.

A high strength steel reinforced drive belt and pulley system provides fast and highly repeatable positioning of the carriage. This high thrust drive belt is securely connected to

the carriage by a unique clamping system. This system provides a secure connection and enables easy belt replacement without the need to remove the payload. Having a low coefficient of friction, the carriage design provides a high mechanical efficiency and long service life. Special carriage lengths and linear units with multiple carriages are available for custom applications.

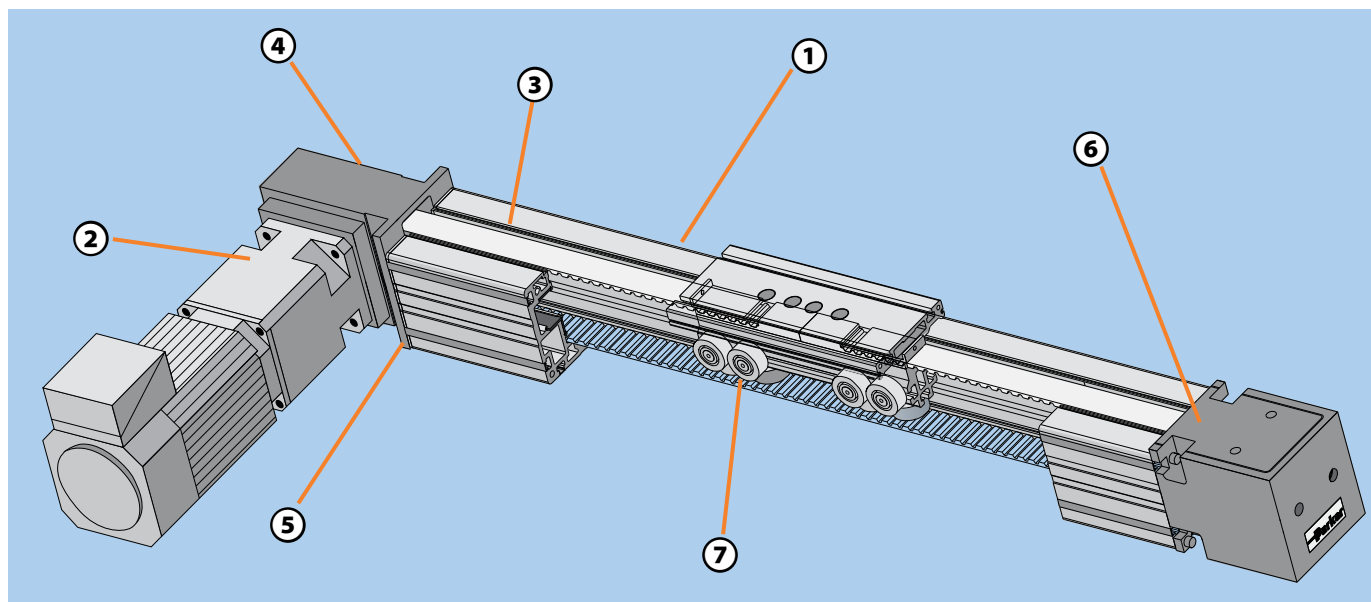

① Carriage

Roller bearing wheels on three sides of the carriage provide smooth linear motion and support and evenly distribute the load across the length of the carriage. Eccentric bearing wheel bushings eliminate play on all sides of the carriage.

② Gearhead

Parker Stealth series gearheads integrated as direct drive options.

③ Drive Belt

A zero backlash, steel reinforced timing belt provides high speed, high force, and high acceleration. A serrated clamp mechanism between belt and carriage guarantees a safe, strong connection and allows belt replacement without removing the load.

④ Drive Station

The drive stations are designed to accept planetary gear reducers or provide different shaft outputs for driving the HPLA.

⑤ Housing

An extruded aluminum profile provides maximum rigidity (torsion and deflection) at minimum weight. It accommodates steel wheels that ride on integral hardened steel bearing ways, or polyamide wheels that ride in the extruded guideway.

⑥ Tensioning Station

An easily accessible tensioning station is used to set the drive belt tension.

⑦ Roller Bearing

Three rows of preloaded heavy duty steel roller bearings provide the highest load carrying capacity available.

Modular drive system

Increased system stiffness due to larger belt width. Low maintenance. High performance due to hollow shaft input.

Modular guide system

Provides an alternative to composite wheel material, with low maintenance and quiet operations. Steel wheel option on an integrated steel rolling surface for increased load capacity, plus high load-bearing capacity and high levels of rigidity.

Various options for adaptation to wide ranging applications

Steel cover strip, corrosion-resistant stainless steel version for application in clean rooms or in the food industry, and integrated position feedback system for maximum precision.

Optional IP30 Strip Seal

Magnetically attached stainless steel seal strip (not shown) provides environmental protection to interior components.

Roller Bearing Design

Each roller bearing incorporates a low friction, lubricated and sealed radial ball bearing enclosed in a hardened steel outer ring (or raceway). A polyamide tread can be substituted for the steel ring whenever whisper quiet motion is desired.

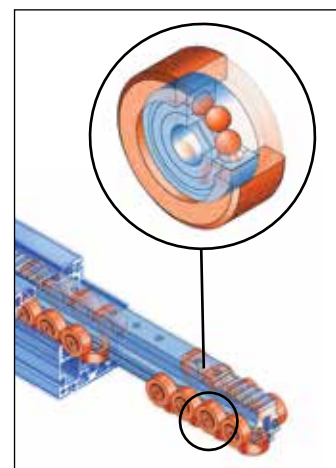

SPECIFICATIONS

As part of the advanced, cost-effective construction of machines and handling systems, the HPLA is a good choice for applications such as materials handling (palletizing, depalletizing, feeding, and part removal), warehouse technology (parts picking, storage and retrieval), and machine tool automation (workpiece loading and unloading, tool changing). Additional examples include textile machinery building (cross-cutting, slitting and stacking, quilting, seam stitching) and construction (formwork and placing reinforcing steel bars in concrete).

Other typical applications are process engineering (painting, coating, bonding), testing technology (guiding ultrasonic sensors, laboratory equipment), and cleanroom technology (wafer transport, wafer coating).



Belt Driven Tables

Characteristic	Units	HPLA80		HPLA120		HPLA180		HPLA180 (Rack Drive)
		Polyamide Wheel	Steel Wheel	Polyamide Wheel	Steel Wheel	Polyamide Wheel	Steel Wheel	Polyamide Wheel
Unit Weight (basic unit without stroke)								
Standard Carriage, NL	kg (lb)	6.8 (15.0)	7.5 (16.5)	20.2 (44.4)	21.6 (47.5)	57.2 (125.8)	61.6 (135.3)	78.4 (172.5)
Extended Carriage, VL	kg (lb)	8.6 (18.9)	9.5 (20.9)	25.2 (55.4)	27.1 (59.6)	74.8 (164.6)	80.9 (178.0)	95.2 (209.4)
Carriage Weight								
Standard Carriage, NL	kg (lb)	1.7 (3.7)	1.8 (4.0)	5.8 (12.8)	6.0 (13.2)	12.3 (27.1)	12.6 (27.7)	32.5 (71.5) ⁽¹⁾
Extended Carriage, VL	kg (lb)	2.6 (5.7)	2.8 (6.2)	8.8 (19.4)	9.2 (20.2)	21.1 (46.4)	21.8 (48.0)	39.8 (87.6) ⁽¹⁾
Weight/Meter of Additional Travel	kg/m (lb/ft)	6.1 (4.1)	7.3 (4.9)	13.7 (9.2)	15.5 (10.4)	29.4 (19.8)	33.6 (22.6)	31.5 (21.2)
Moment of Inertia (related to the drive shaft)								
Standard Carriage, NL	kg-cm ² (lb-in ²)	17.8 (6.1)	18.4 (6.3)	142 (48)	146 (50)	725 (247)	743 (253)	698 (238)
Extended Carriage, VL	kg-cm ² (lb-in ²)	25.4 (8.7)	26.5 (9.0)	197 (67)	204 (70)	1121 (382)	1154 (393)	845 (288)
Travel and Speed								
Maximum Speed ⁽²⁾	m/s (in/s)	5 (200)		5 (200)		5 (200)		5 (200)
Maximum Acceleration ⁽²⁾	m/s ² (in/s ²)	10 (393)		10 (393)		10 (393)		10 (393)
Max. Travel, Standard Carriage NL ⁽³⁾	mm (in)	5540 (218)	5520 (217)	9470 (372)	9440 (371)	9240 (363)	9200 (362)	8680 (341)
Max. Travel, Extended Carriage VL ⁽³⁾	mm (in)	5390 (212)	5370 (211)	9270 (365)	9240 (363)	8940 (352)	8900 (350)	8380 (330)
Geometric Data								
Cross Section, Square	mm (in)	80 (3.15)		120 (4.72)		180 (7.09)		180 (7.09)
Moment of Inertia I _x	cm ⁴ (in ⁴)	139 (3.34)		724 (17.39)		3610 (86.73)		3610 (86.73)
Moment of Inertia I _y	cm ⁴ (in ⁴)	165 (3.96)		830 (19.94)		4077 (97.95)		4077 (97.95)
Moment of Elasticity	N/mm ² (lb/in ²)	0.72 x 10 ⁵ (0.1044 x 10 ⁶)		0.72 x 10 ⁵ (0.1044 x 10 ⁶)		0.72 x 10 ⁵ (0.1044 x 10 ⁶)		0.72 x 10 ⁵ (0.1044 x 10 ⁶)
Pulley Data, Torques, Forces								
Travel Distance per Revolution	mm/rev (in/rev)	180 (7.09)		270 (10.63)		420 (16.54)		280 (11.02)
Response Radius of Drive Pulley	mm (in)	28.7 (1.13)		43.0 (1.69)		66.8 (2.63)		44.6 (1.75)
Maximum Drive Torque	Nm (lb-in)	47.4 (420)		131.4 (1165)		368 (3264)		58 (514)
Maximum Belt Traction (effective load)		Refer to Load-Bearing Capacity and Maximum Permissible Moment Load Charts						
Repeatability ⁽³⁾⁽⁴⁾	mm (in)	± 0.2 (± 0.008)		± 0.2 (± 0.008)		± 0.2 (± 0.008)		± 0.05 (± 0.002)

(1) Includes weight of drive module.

(2) Greater speeds and accelerations may be achieved.

(3) Bumper to bumper maximum stroke - splicing possible for longer travel distances including safety zone.

(4) Nominal value - component dependent. For improved repeatability consult factory.

HPLA080 Series – Load-Bearing Capacity of Carriage and Timing Belt

Load-Bearing Capacity of HPLA080 Timing Belt (F_x)

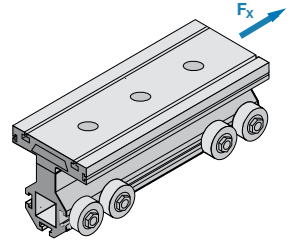

The forces and moments that the carriage is capable of transferring are speed-dependent. The curves shown in the graphs apply to a standard carriage (S). With the extended carriage (E), all the values apart from F_x (load-bearing capacity of timing belt) can be doubled if the load is applied equally to both halves of the carriage or distributed uniformly along its entire length.

Description	Gearhead	Drive Option	Transferable Thrust Force (n)	
			Nominal Belt Tension (81,000 km life)	Maximum Belt Tension (46,000 km life)
Supported Pulley	PX90/PX115 PV90/PV115 PS90	S03/S04/ S08/S09	925	1115

The forces and moments that the carriage is capable of transferring are speed-dependent. The curves shown in the graphs apply to a standard carriage (S). With the extended carriage (E), all the values apart from F_x (load-bearing capacity of timing belt) can be doubled if the load is applied equally to both halves of the carriage or distributed uniformly along its entire length.

HPLA080 Load-Bearing Capacity (F_y and F_z)

(Values double for extended carriage)

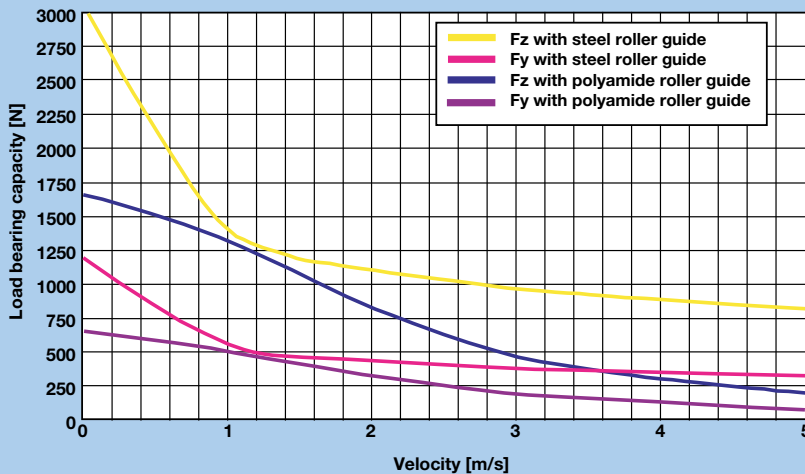

The curves show the maximum load-bearing capacity of a carriage in one direction of force or torque. If several loads are applied in different directions, the values given by the curves must be derated, i.e. the load or speed should be reduced if necessary.

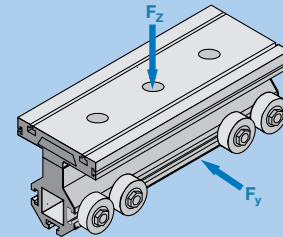

HPLA080 Maximum Permissible Moment Load (M_x , M_y and M_z)

(Values double for extended carriage)

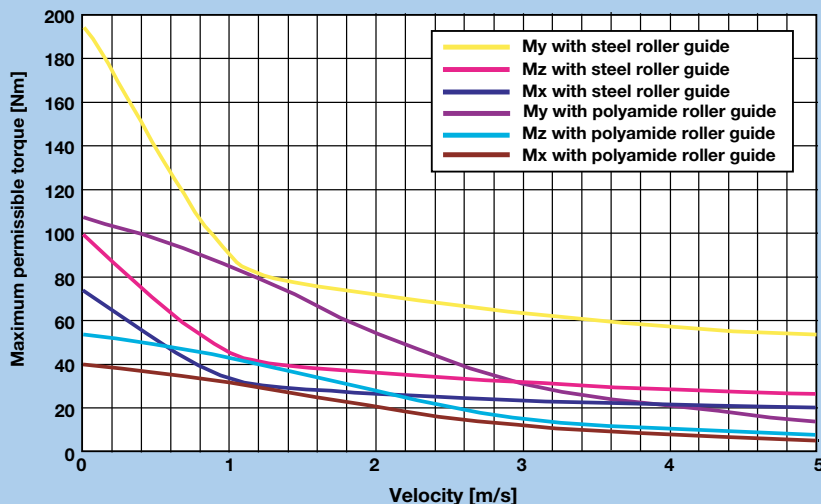

Virtual Engineer software is available for determination of precise carriage loading.

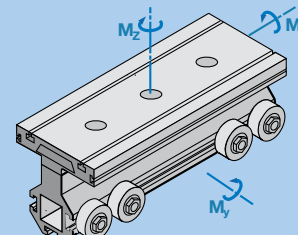

HPLA120 Series – Load-Bearing Capacity of Carriage and Timing Belt

Load-Bearing Capacity of HPLA120 Timing Belt (Fx)

Description	Gearhead	Drive Option	Transferable Thrust Force (n)	
			Nominal Belt Tension (81,000 km life)	Maximum Belt Tension (46,000 km life)
Supported Pulley	PV115 PX115 PS90/PS115	S03/S04/ S08/ S09	1700	2235

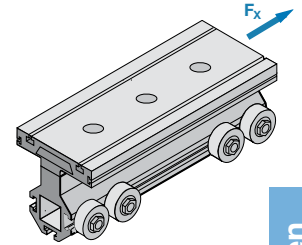

The forces and moments that the carriage is capable of transferring are speed-dependent.

The curves shown in the graphs apply to a standard carriage (S). With the extended carriage (E), all the values apart from Fx (load-bearing capacity of timing belt) can be doubled if the load is applied equally to both halves of the carriage or distributed uniformly along its entire length.

Belt Driven Tables

HPLA120 Load-Bearing Capacity (Fy and Fz)

(Values double for extended carriage)

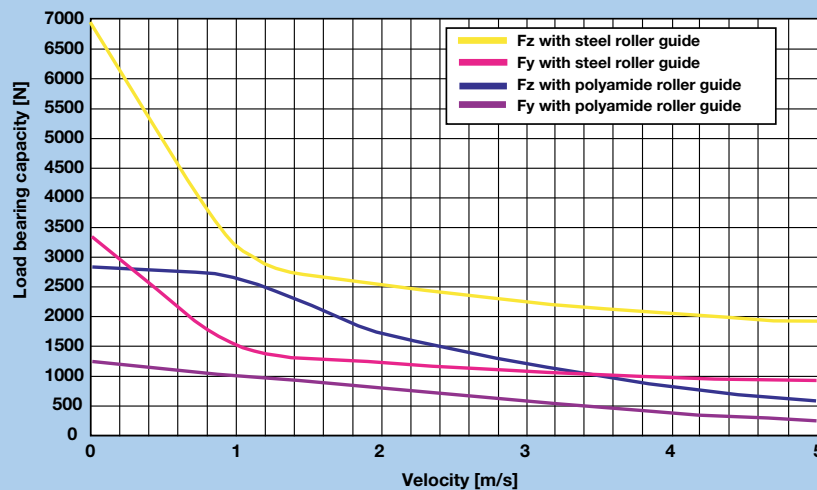

The curves show the maximum load-bearing capacity of a carriage in one direction of force or torque. If several loads are applied in different directions, the values given by the curves must be derated, i.e. the load or speed should be reduced if necessary.

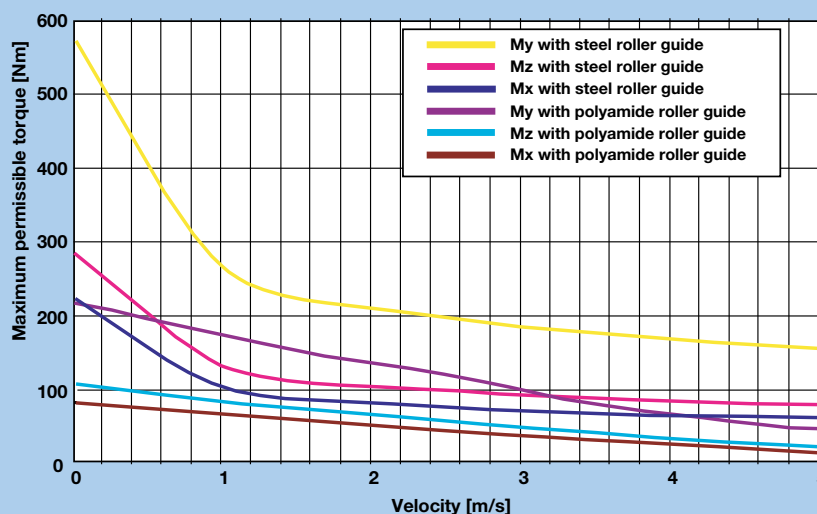
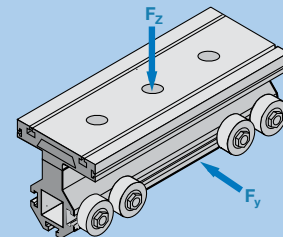

Virtual Engineer software is available for determination of precise carriage loading.

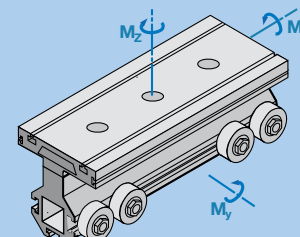

HPLA180 Series – Load-Bearing Capacity of Carriage and Timing Belt

Load-Bearing Capacity of HPLA180 Timing Belt (Fx)

Description	Gearhead	Drive Option	Transferable Thrust Force (n)	
			Nominal Belt Tension (81,000 km life)	Maximum Belt Tension (46,000 km life)
Supported Pulley	PS115 PS142	S03/S04/ S08/S09	4170	5455

The forces and moments that the carriage is capable of transferring are speed-dependent.

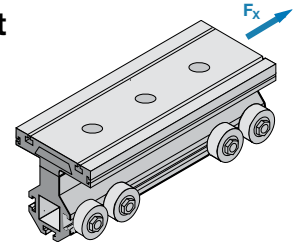

The curves shown in the graphs apply to a standard carriage (S). With the extended carriage (E), all the values apart from Fx (load-bearing capacity of timing belt) can be doubled if the load is applied equally to both halves of the carriage or distributed uniformly along its entire length.

HPLA180 Load-Bearing Capacity (Fy and Fz)

(Values double for extended carriage)

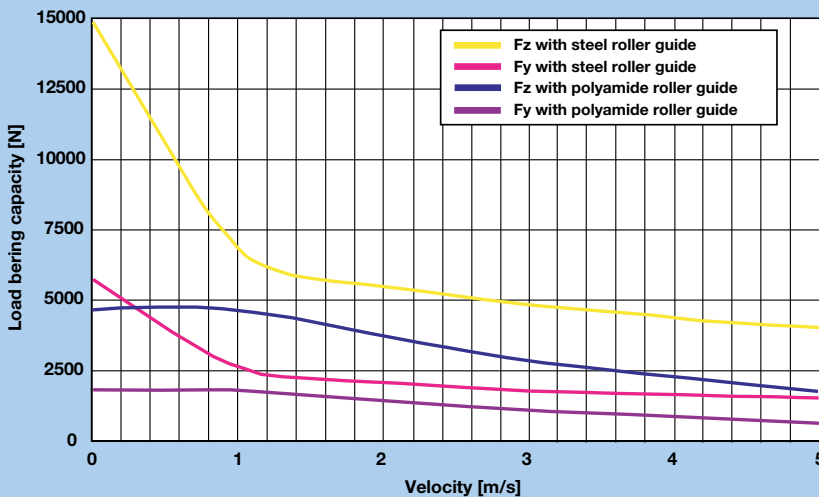

The curves show the maximum load-bearing capacity of a carriage in one direction of force or torque. If several loads are applied in different directions, the values given by the curves must be derated, i.e. the load or speed should be reduced if necessary.

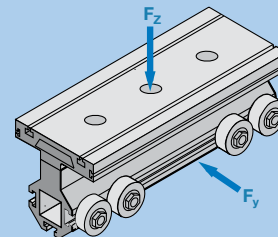

HPLA180 Maximum Permissible Moment Load (Mx, My and Mz)

(Values double for extended carriage)

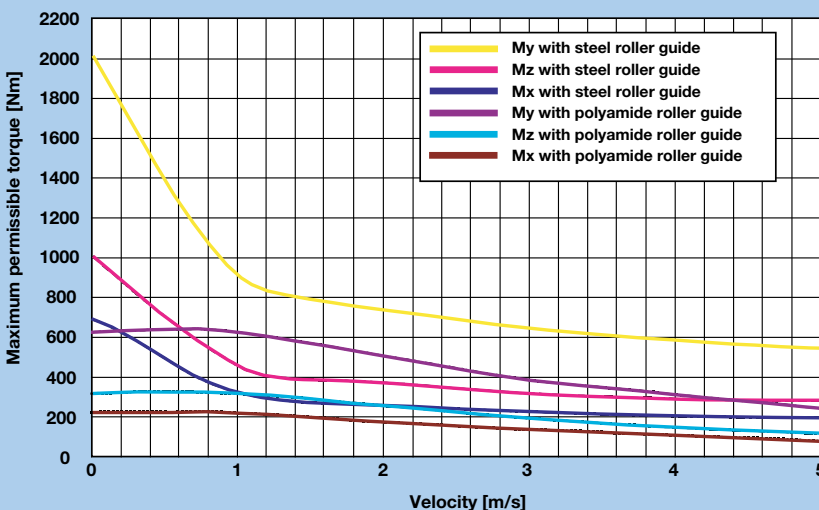

Virtual Engineer software is available for determination of precise carriage loading.



parker.com/VirtualEngineer

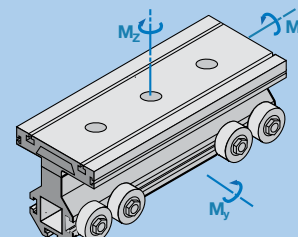

HPLA Characteristics

The HPLA deflection curves can be used for determining the deflection based on the profile length and the application load weight. Applications requiring high acceleration forces can place a severe strain on the system stability. In these cases, a solid substructure may be required with the HPLA product being supported at frequent intervals.

These deflection curves illustrate the deflection d , based on the HPLA profile being simply supported at both ends. The graphs take into consideration the self deflection due to the weight of the profile, along with the load to be transported. The maximum deflection cannot be exceeded. If the maximum deflection is exceeded based on your application parameters, then additional supports are required. Alternatively, the next larger profile size may be considered. For deflection formulas and calculations, please refer to the Technical Information Library found on our web site: www.parkermotion.com

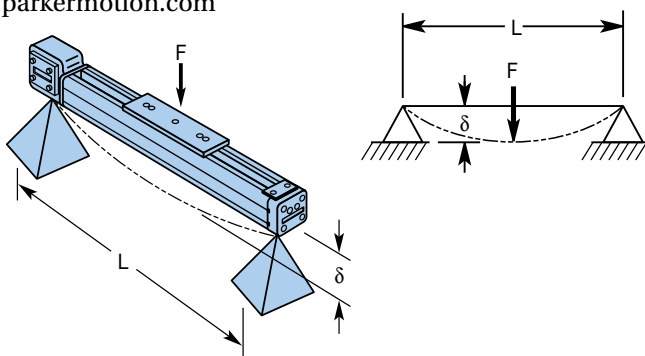

F = Force N
 L = Unsupported length mm
 δ = Deflection mm

Deflection Curves

HPLA080

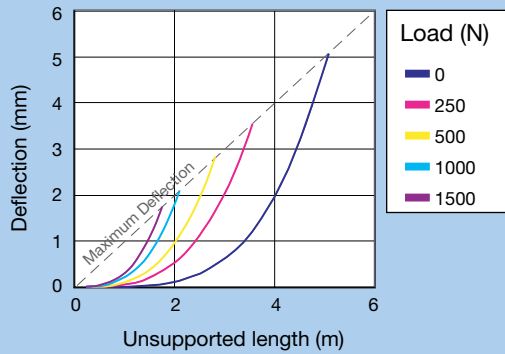

HPLA120

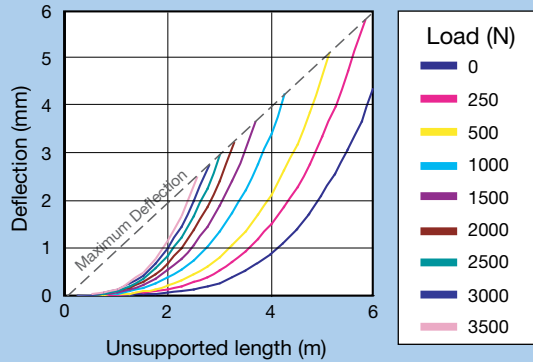

HPLA180

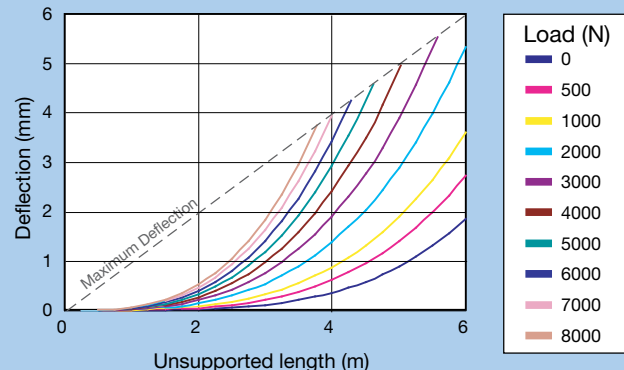

Belt Driven Tables

Dual Axis Considerations

When two parallel linear modules are required to form a single axis, the span or distance between each unit determines which type of shaft connection is required. In some cases, a link shaft support bearing might also be required.

The link shaft bearing is used to support the linking shaft of an HPLA dual axis when there is a large center to center distance. This bearing must be used if the critical speed is exceeded with the dual-axis link shaft.

Figure A

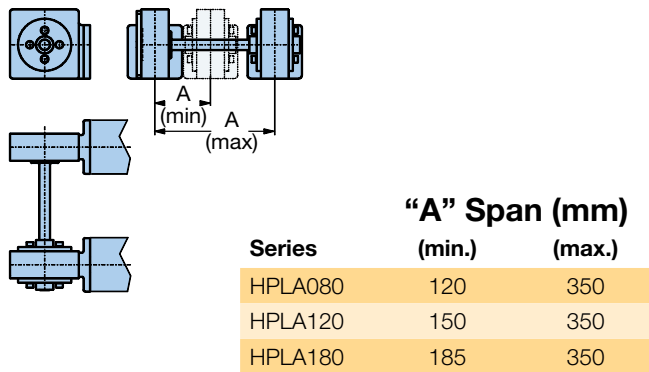
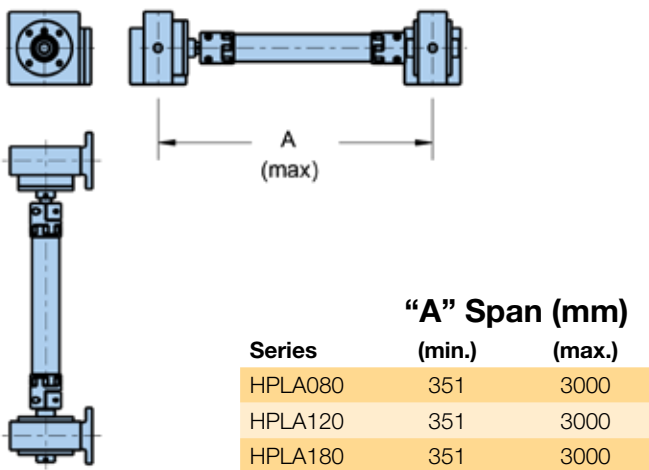
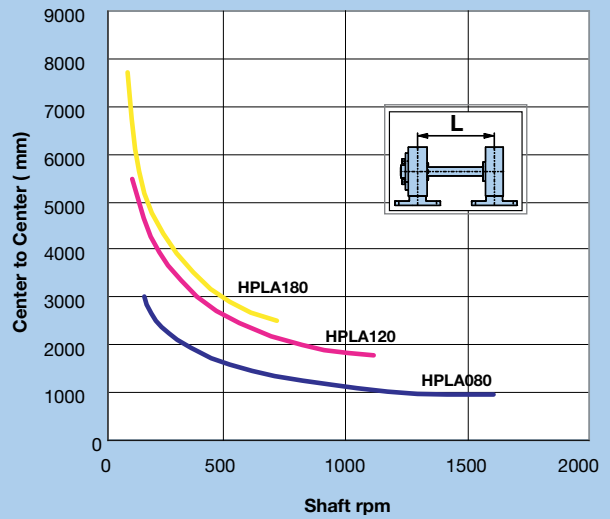

Figure B



Critical Speed



Linear Velocity

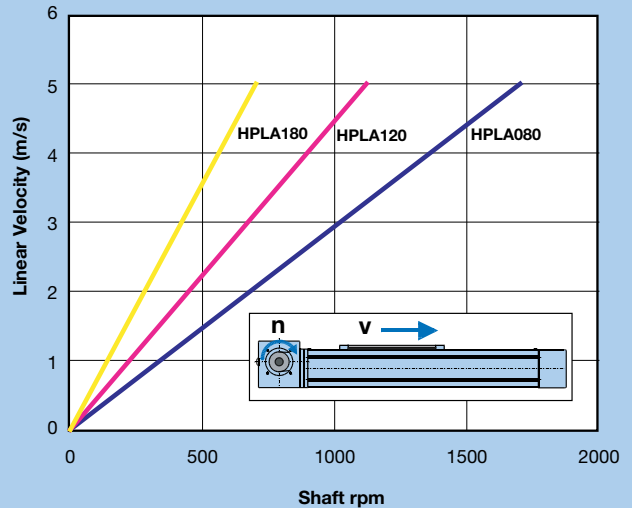

DIMENSIONS

Download 2D & 3D files from
www.parker.com/emn/HPLA080



DIMENSIONS

HPLA080 Drive Unit

Dimensions (mm)

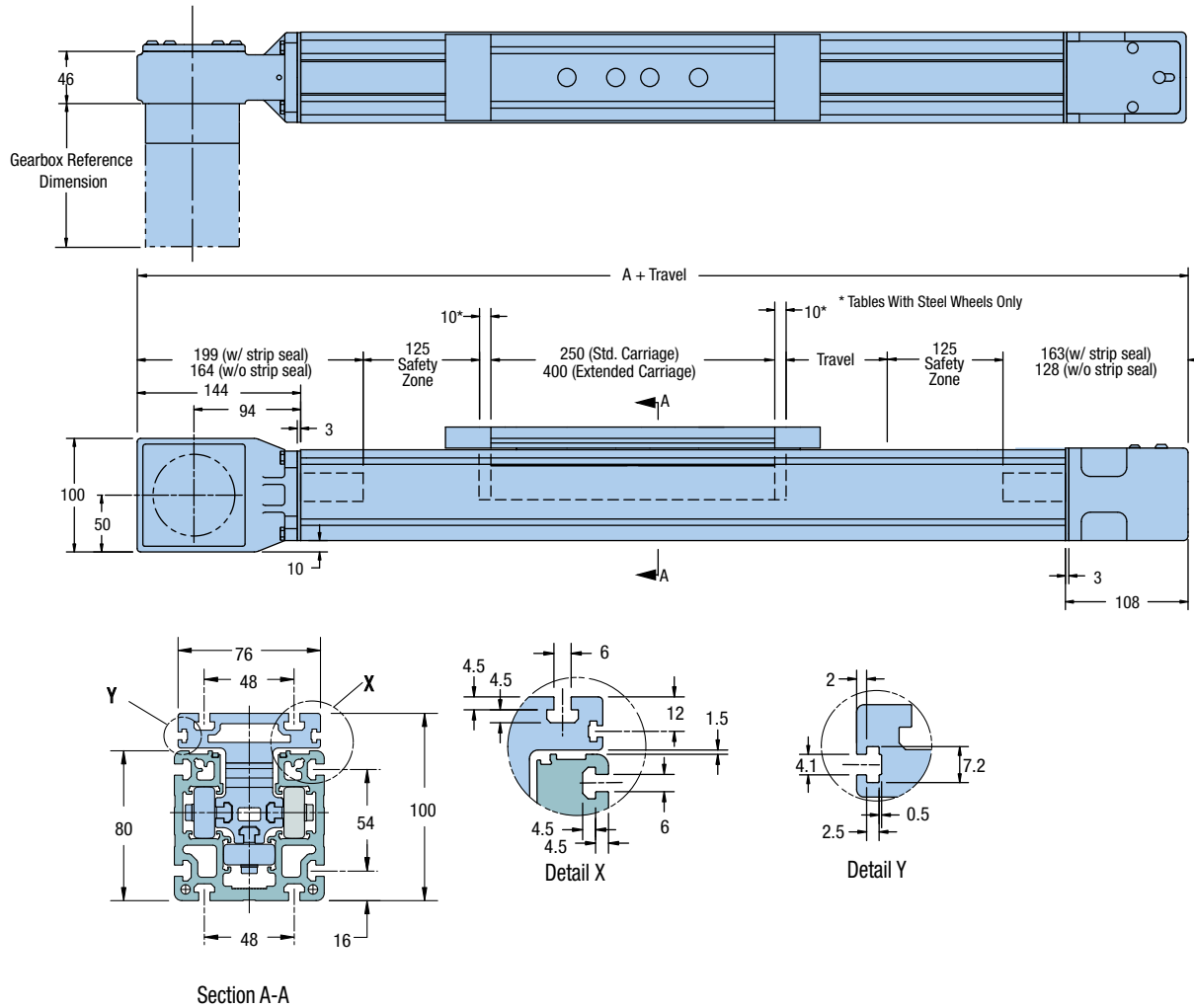

Belt Driven
Tables

Dimension A (mm)

Description	With Strip Seal	Without Strip Seal
Standard Carriage - Polyamide Wheels	862	792
Standard Carriage - Steel Wheels	882	812
Extended Carriage - Polyamide Wheels	1012	942
Extended Carriage - Steel Wheels	1032	962

Free sizing and selection support
 from Virtual Engineer at
parker.com/VirtualEngineer



HPLA120 Drive Unit

Dimensions (mm)

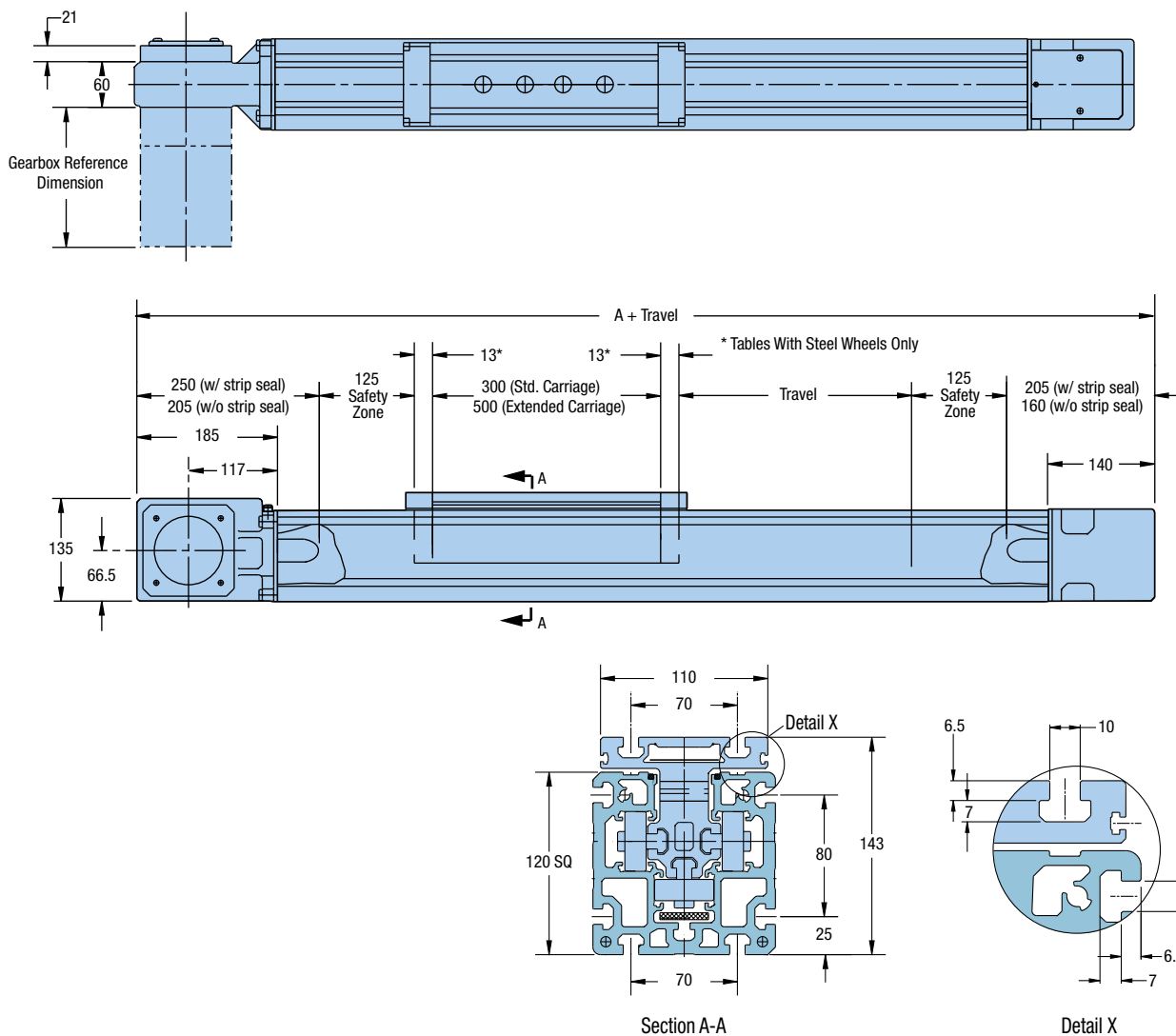

Dimension A (mm)

Description	With Strip Seal	Without Strip Seal
Standard Carriage - Polyamide Wheels	1005	915
Standard Carriage - Steel Wheels	1031	941
Extended Carriage - Polyamide Wheels	1205	1115
Extended Carriage - Steel Wheels	1231	1141



HPLA180 Drive Unit

Dimensions (mm)

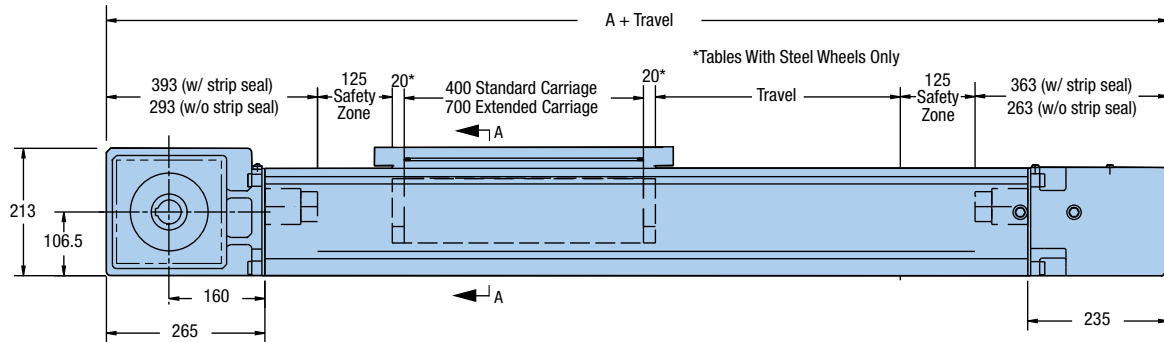
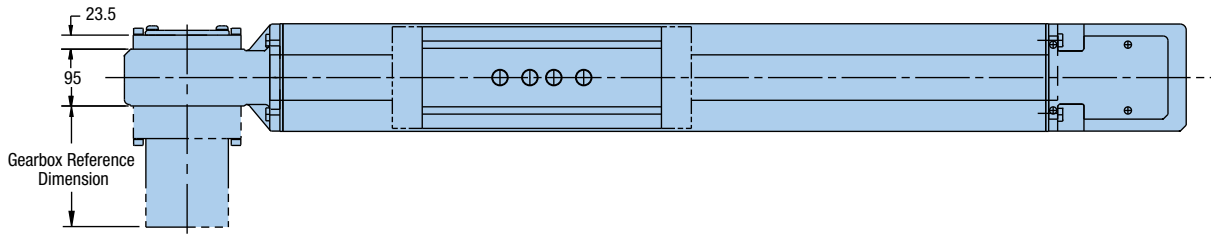

Dimension A (mm)

With Strip Seal Without Strip Seal

Description	With Strip Seal	Without Strip Seal
Standard Carriage - Polyamide Wheels	1408	1206
Standard Carriage - Steel Wheels	1446	1246
Extended Carriage - Polyamide Wheels	1706	1506
Extended Carriage - Steel Wheels	1746	1546

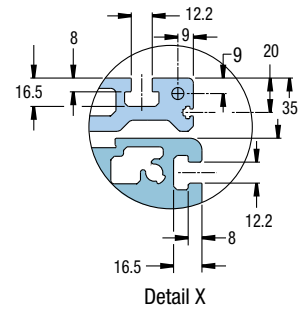
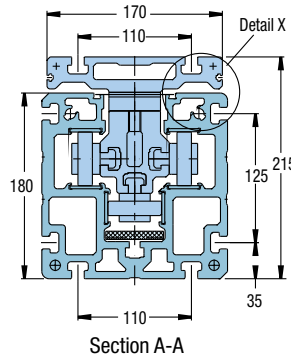

Free sizing and selection support
from Virtual Engineer at
parker.com/VirtualEngineer



Idler Unit Dimensions

Dimensions (mm)

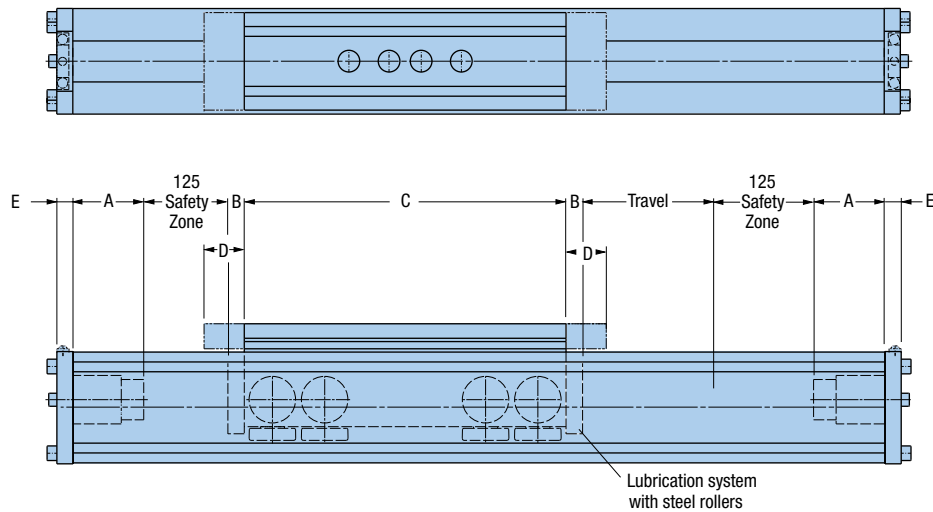

Dimensions (mm)

Series	Carriage Length	Wheel Type	With Strip Seal					Without Strip Seal				
			A	B	C	D	E	A	B	C	D	E
HPLA080	Standard	Polyamide	55	-	250	40	10	20	-	250	-	10
HPLA080	Extended	Polyamide	55	-	400	40	10	20	-	400	-	10
HPLA080	Standard	Steel	55	10	250	40	10	20	10	250	-	10
HPLA080	Extended	Steel	55	10	400	40	10	20	10	400	-	10
HPLA120	Standard	Polyamide	65	-	300	50	15	20	-	300	-	15
HPLA120	Extended	Polyamide	65	-	500	50	15	20	-	500	-	15
HPLA120	Standard	Steel	65	13	300	50	15	20	13	300	-	15
HPLA120	Extended	Steel	65	13	500	50	15	20	13	500	-	15
HPLA180	Standard	Polyamide	128	-	400	100	20	28	-	400	-	20
HPLA180	Extended	Polyamide	128	-	700	100	20	28	-	700	-	20
HPLA180	Standard	Steel	128	20	400	100	20	28	20	400	-	20
HPLA180	Extended	Steel	128	20	700	100	20	28	20	700	-	20

HPLA/HLE OPTIONS & ACCESSORIES

Limit and home sensors, switches, cable carriers, splice plates, and more.

See Options & Accessories at the end of the belt-driven section.

ORDERING INFORMATION

HPLA

Fill in an order code from each of the numbered fields to create a complete model order code.

① ② ③ ④ ⑤ ⑥ ⑦ ⑧ ⑨ ⑩ ⑪ ⑫ ⑬ ⑭

Order Example: HPLA080 D1 B1 T2000 C1 DA1000 S08 F02 G2-05 K24 R1 H1 LH1 E1

- ① **Series**
HPLA080
HPLA120
HPLA180
- ② **Drive System**
D0 Idler Unit
D1 Timing Belt Drive, Nominal Thrust, Maximum Life
D2 Timing Belt Drive, Maximum Thrust, Nominal Life
- ③ **Bearing Option**
B1 Polyamide Rollers
*B2 Steel Rollers
* For steel roller option in vertical and inverted orientations, please consult factory for special instructions.
- ④ **Travel**
Tnnnn Specified travel in mm (nnnn = mm)
- ⑤ **Carriage**
- C1 Standard Length Carriage with Load Plate*
C2 Extended Length Carriage with Load Plate*
C3 Standard Length Carriage with Clamping Bar*
C4 Extended Length Carriage with Clamping Bar*
* See photos below.
- ⑥ **Link Shaft Option**
DA0000 No Link Shaft - Single Axis or Idler Unit
DAnnnn Double Unit, Specify Center to Center Distance (mm)
- ⑦ **Drive Shaft Configuration**
S00 No Shaft, Idler Unit
S03 Supported Pulley, Flange Left
S04 Supported Pulley, Flange Right
S05 Supported Pulley, Shaft Option, Left
S06 Supported Pulley, Shaft Option, Right
S07 Supported Pulley, Shaft Option, Both
S08 Supported Pulley, Flange Left, Shaft Right
S09 Supported Pulley, Flange Right, Shaft Left
- ⑧ **Drive Housing Flange**
F00 No Flange
F08 PV90/PX90 Flange (HPLA80 ONLY)
F09 PX115/PV115 Flange (HPLA080 and HPLA120 only)
F10 PS90 Flange (HPLA080 and HPLA120 only)
F11 PS115 Flange (HPLA120 & HPLA180 only)
F12 PS142 Flange (HPLA180 only)

Belt Driven Tables

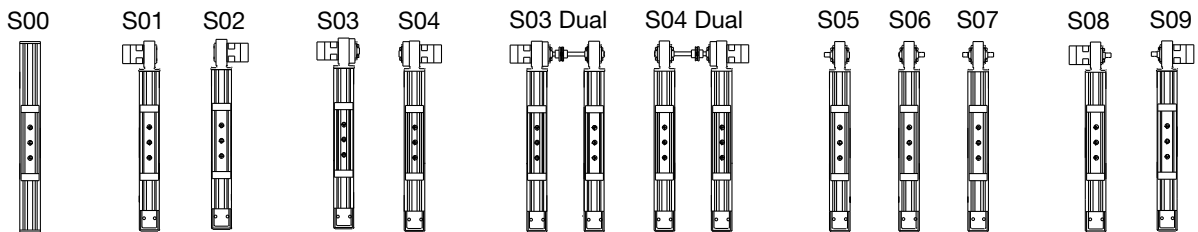

Free sizing and selection support
from Virtual Engineer at
parker.com/VirtualEngineer



Fill in an order code from each of the numbered fields to create a complete model order code.

① ② ③ ④ ⑤ ⑥ ⑦ ⑧ ⑨ ⑩ ⑪ ⑫ ⑬ ⑭

Order Example: HPLA080 D1 B1 T2000 C1 DA1000 S08 F02 G2-05 K24 R1 H1 LH1 E1

⑨ **Gearbox Option**

- G0-00 No Gearbox
 - G08-nn PX90 Gearbox included
 - G09-nn PX115 Gearbox included
 - G10-nn PS90 Gearbox included
 - G11-nn PS115 Gearbox included
 - G12-nn PS142 Gearbox included
 - G14-nn PV90 Gearbox included
 - G15-nn PV115 Gearbox included
- nn = ratio
Single stage ratios 3:1, 5:1, 10:1 Dual stage ratios 15:1, 25:1

⑩ **Motor Kit Option**

- K00 No Flange
- K20 NEMA23 stepper, 1/4" shaft
- K21 BE23
- K23 SMN60, MPM72 (metric), N070, J070
- K24 SMN82, MPM89 (metric), N092, J092
- K26 BE34
- K34 MPP092x motor kit
- K36 Parker MPP100/MPJ100
- K39 Parker MPP115/MPJ115
- K41 Parker MPP142/MPJ142
- K50 Parker HDY55; MPL15XX (Allen Bradley)
- K51 AKM3X-AN (Kollmorgen)
- K52 SGMAH-04 (Yaskawa)
- K53 SGMAH-08 (Yaskawa)
- K54 MKD041 (Indramat)
- K55 AKM4X-AN (Kollmorgen)
- K56 MKD070 (Indramat)
- K57 MKD090 (Indramat)

⑪ **Environmental Option**

- R1 Standard preparation with strip seal ¹
- R2 Standard preparation with no strip seal
- R3 Corrosion resistant preparation with strip seal ^{1, 2}
- R4 Corrosion resistant preparation with no strip seal ²

¹ C1, C2 Carriage Load Plate Only

² B1 Bearing Option Polyamide Rollers Only)

⑫ **Mounting Orientation**

- H1 Carriage Up
- H2 Carriage Down
- H3 Carriage on Side, Drive Station Up
- H4 Carriage on Side, Drive Station Down

⑬ **Limit/Home Switch Option***

- LH0 No Limit Switch Assembly
- LH3 Three NPN Prox Switches, 10-30 VDC
- LH4 Three PNP Prox Switches, 10-30 VDC

*C1, C2 Carriage Load Plate Only

⑭ **Linear Encoder**

- E1 Without Linear Encoder
- E5* 5.0 Micron Resolution, Magnetic Type
- E7* Sine Cosine Output, Magnetic Type

*C1, C2 Carriage Load Plate Only

*Consult factory for linear encoder options and quotation.

HLE-RB Series Belt Driven Linear Modules

Belt-Drive Actuators for High Thrust, Long Stroke Applications

Belt Driven
Tables

- Standard travel up to 7.9 meters*
 - Load Capacities up to 600 kg
 - ±0.2 mm positional repeatability
 - Timing belt and pulley drive mechanism for fast, accurate positioning
 - Roller wheel bearings for smooth high speed linear motion
 - IP30 strip seal
- *Longer travels available with splice kits.



Design Advantages

- Low running friction
- Low particle generation (clean room suitability to class 100)
- Low wear and low maintenance
- Quiet operation
- High efficiency and long service life
- High dynamic performance due to low-mass, play-free wheels
- Minimal preventative maintenance required
- T-slots integrated on all sides of the profile for mounting attachments or for use as a cable duct
- Timing belts can be replaced without removing load attachment plate
- Multiple configuration options due to T-slots available on both the profile and load plate

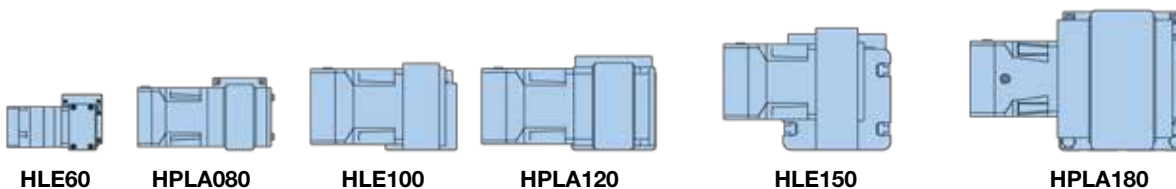

	HLE60	HPLA80	HLE100	HPLA120	HLE150	HPLA180
Maximum Travel (mm)	4,000	5,540	6,200	9,470	7,900	9,240
Maximum Payload (N)	353	1,304	1,549	2,598	3,402	4,501
Maximum Acceleration (m/s²)	10	10	10	10	10	10

*Do not exceed allowable axial and moment loading.

The HLE-RB linear modules are ideal as single axis products or as components for high speed multi-axis gantries. With thousands of units in operation worldwide the HLEs are proven performers offering long life and trouble-free operation.

The HLE Linear Module consists of a lightweight carriage which can be precisely positioned within an extruded aluminum housing by a timing belt and pulley drive

system. The housing, constructed from extruded aluminum with a square cross sectional geometry, demonstrates excellent deflection characteristics.

The protective anolite coating provides durability as well as an attractive silver appearance. It includes T-slots along its entire length for flexible mounting. The drive mechanism is a zero backlash steel reinforced timing belt. The tension station, conveniently

located at the end of the unit provides for quick and easy belt adjustment. The drive station is designed to accept planetary gear reducers as well as a wide variety of servo and stepper motors. The bearing system for the RB models is comprised of three rows of roller wheels integral to the carriage which are guided by extruded tracks within the housing.

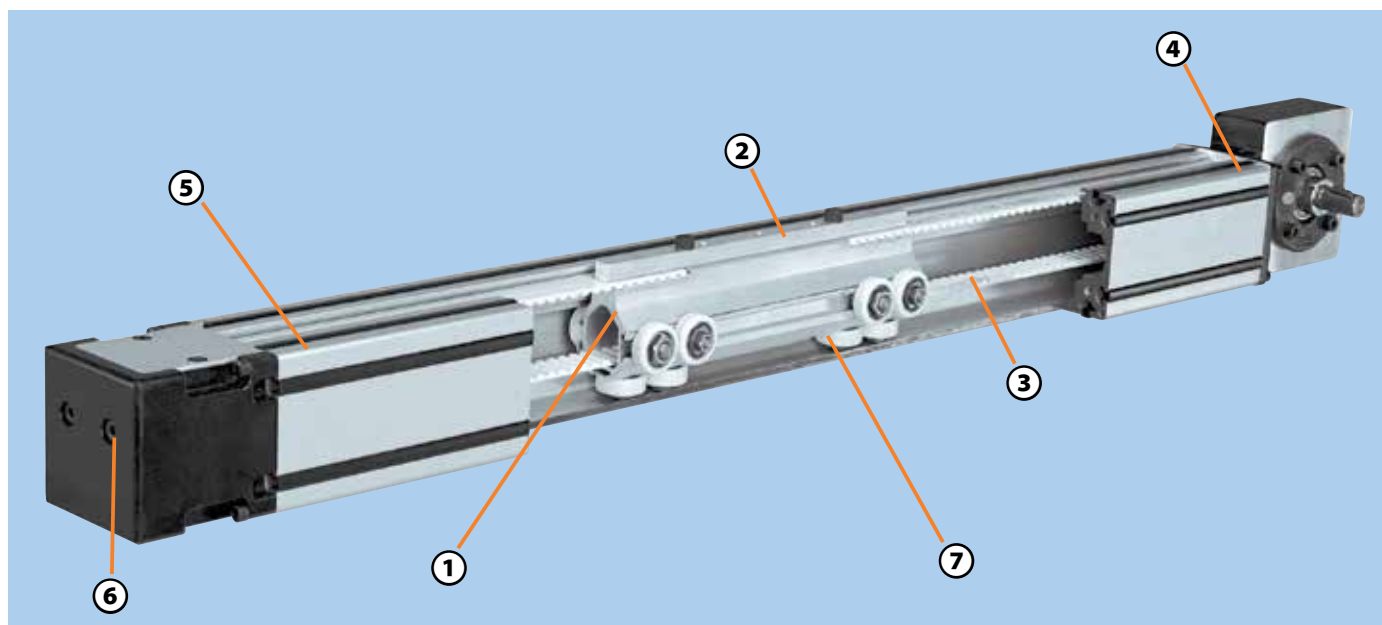

① Carriage

Roller bearing wheels are installed on three sides of the carriage to provide smooth linear motion and support. The wheels are positioned to evenly distribute the load across the length of the carriage. Eccentric bearing wheel bushings are adjusted to eliminate play on all sides of the carriage. Due to a low coefficient of friction, the carriage design provides a high mechanical efficiency and long service life. The carriages are available in standard and extended lengths. Special carriage lengths and linear units with multiple carriages are available for custom applications.

② Load Attachment Plate

Load attachment plates are available for every type of carriage. With integral T-slots or tapped with holes in a standard mounting pattern, they allow easy mounting of your load to the carriage of the HLE. Multiple HLEs can easily be mounted together by using standard clamping profiles. Tripping plates are mounted to the side of the load attachment plate to activate home or end of travel switches mounted to the side of the HLE. For special applications, the load plates can be designed to customer specified requirements.

③ Drive Belt

A zero backlash, steel reinforced timing belt provides high speed, high acceleration and good bidirectional repeatability.

④ Drive Station

Rigid cast housing with standard flanges for a variety of gearboxes. The drive stations are designed to accept planetary and worm gear reducers or provide different shaft outputs for driving the HLE.

⑤ Housing

Lightweight and self-supporting aluminum profiles are offered in three sizes:

HLE60:	60 x 60 mm
HLE100:	100 x 100 mm
HLE150:	150 x 150 mm

T-slots are provided for mounting the linear unit itself, applying additional components and accessories, or combining multiple HLEs. T-slots with plastic covers provide a simple cable conduit.

⑥ Tensioning Station

"Easy access" tensioning bolts allow external adjustment of belt tension.

⑦ Roller Bearing

Each wheel consists of a lubricated and sealed radial ball bearing to reduce friction and maintenance. The bearing is enclosed within a tough polyamide tread to reduce noise and provide long service life.

Optional Features

- Direct mounting for planetary gear reducers
- Adjustable "end of travel" limit switches and "home" position sensor
- Clean room preparation option
- Cable carrier systems
- Performance matched Parker servo systems
- Structural components for vertical and multi-axis mounting
- Toe clamps and hardware for fast and easy mounting
- External bumpers
- Link shafts and support bearings for dual axis units
- Splice plates for extending travels beyond length available in a single profile

IP30 Strip Seal

Magnetically attached stainless steel seal strip (not shown) provides environmental protection to interior components.

HPLA/HLE OPTIONS & ACCESSORIES

Limit and home sensors, switches, cable carriers, splice plates, and more. See Options & Accessories at the end of the belt-driven section.

SPECIFICATIONS

HLE-RB Series

As part of the advanced, cost-effective construction of machines and handling systems, the HPLA is a good choice for applications such as materials handling (palletizing, depalletizing, feeding, and part removal), warehouse technology (parts picking, storage and retrieval), and machine tool automation (workpiece loading and unloading, tool changing). Additional examples include textile machinery building (cross-cutting, slitting and stacking, quilting, seam stitching) and construction (formwork and placing reinforcing steel bars in concrete).



Other typical applications are process engineering (painting, coating, bonding), testing technology (guiding ultrasonic sensors, laboratory equipment), and cleanroom technology (wafer transport, wafer coating).

Belt Driven Tables

Characteristic	Units	HLE60-RB		HLE100-RB		HLE150-RB	
Unit Weight (basic unit without stroke)							
Standard Carriage, NL	kg (lb.)	2.28	(5.03)	12.70	(28.00)	31.20	(68.80)
Extended Carriage, VL	kg (lb.)	3.98	(8.77)	15.80	(34.84)	38.50	(84.89)
Carriage Weight							
Standard Carriage, NL	kg. (lb)	0.8	(1.76)	2.80	(6.17)	7.30	(16.10)
Extended Carriage, VL	kg. (lb)	1.3	(2.87)	4.40	(9.70)	11.50	(25.36)
Weight per meter of additional length	kg/m (lb/ft)	3.62	(2.43)	10.00	(6.72)	21.10	(14.18)
Moment of Inertia (related to the drive shaft)							
Standard Carriage, NL	kg-cm ² (lb-in ²)	3.07	(1.05)	24.60	(8.41)	123.30	(42.17)
Extended Carriage, VL	kg-cm ² (lb-in ²)	4.81	(1.64)	36.40	(12.45)	183.60	(62.79)
Travel and Speed							
Maximum Speed ⁽¹⁾	m/s (in/s)	5	(120)	5	(200)	5	(200)
Maximum Acceleration ⁽¹⁾	m/s ² (in/s ²)	10	(393)	10	(393)	10	(393)
Maximum Travel ⁽²⁾ —standard carriage, NL	m (in)	4.0	(160)	6.2	(244)	7.9	(311)
Maximum Travel ⁽²⁾ —extended carriage, VL	m (in)	3.8	(149)	6.0	(238)	7.7	(305)
Geometric Data							
Cross Section, Square	mm (in)	57.1	(2.25)	100.0	(3.94)	150.0	(5.91)
Moment of Inertia I _x	cm ⁴ (in ⁴)	55.8	(1.34)	383.0	(9.20)	1940.0	(46.61)
Moment of Inertia I _y	cm ⁴ (in ⁴)	56.2	(1.35)	431.0	(10.35)	2147.0	(51.58)
Moment of Inertia I _z	N/mm ²	0.72 x	(0.1044 x	0.72 x	(0.1044 x	0.72 x	(0.1044 x
Moment of Elasticity	(lb/in ²)	10 ⁵	10 ⁵)	10 ⁵	10 ⁵)	10 ⁵	10 ⁵)
Pulley Data, Torques, Forces							
Travel Distance per Revolution	mm/rev (in/rev)	125	(4.92)	170	(6.69)	240	(9.45)
Pulley Diameter	mm (in)	39.8	(1.57)	54.1	(2.13)	76.4	(3.01)
Maximum Drive Torque ⁽³⁾	Nm (lb-in)	8.87	(78.5)	40.0	(354.0)	108.0	(955.9)
Maximum Belt Traction ⁽³⁾ (effective load)	N (lb)						
Repeatability ⁽⁴⁾	mm (in)	±0.2	(±0.008)	±0.2	(±0.008)	±0.2	(±0.008)

For the following deviations from the above standards, please contact Parker engineering:

- (1) Greater speeds and accelerations may be achieved.
- (2) Splicing possible for longer travel distances. This may cause reductions in effective load, drive torque, speed, acceleration, and repeatability. Consult factory for strip seal availability on spliced units.
- (3) Increased timing belt tension required.
- (4) Nominal value - component dependent. For improved repeatability consult factory.

The T-slots of the load attachment plate and the HLE profile are suitable for T-nuts and T-bolts.

Plastic caps protect the interior from dust.

A spring-loaded felt insert cleans the strip seal.

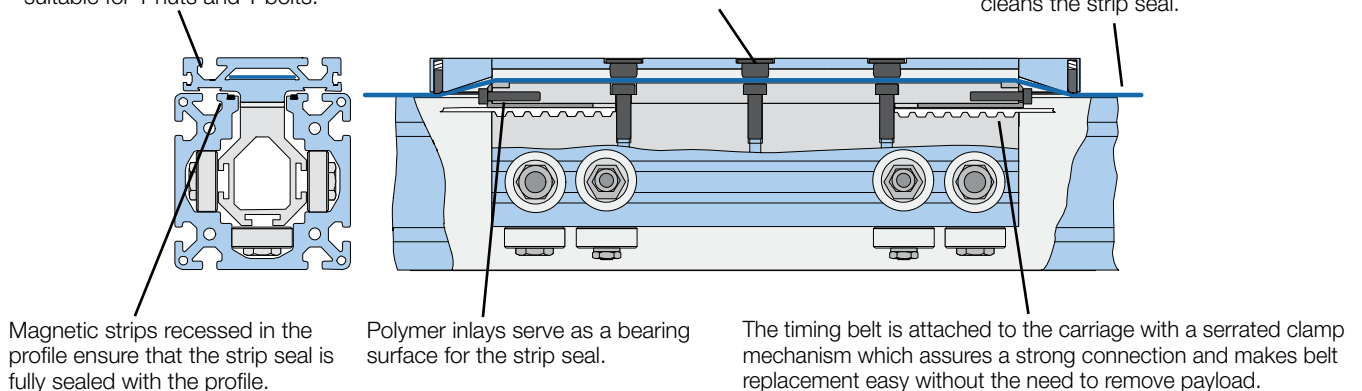

HLE60-RB Series – Load-Bearing Capacity of Carriage and Timing Belt

Load-Bearing Capacity of HLE-60RB Timing Belt (Fx)

HLE60-RB Drive Option	Transferable Thrust Force (n)	
	Nominal Belt Tension (81,000 km life)	Maximum Belt Tension (46,000 km life)
Supported Pulley (SP19 - SP30)	500	–

The forces and moments that the carriage is capable of transferring are speed-dependent. The curves shown in the graphs apply to a standard carriage (S). With the extended carriage (E), all the values apart from Fx (load-bearing capacity of timing belt) can be doubled if the load is applied equally to both halves of the carriage or distributed uniformly along its entire length.

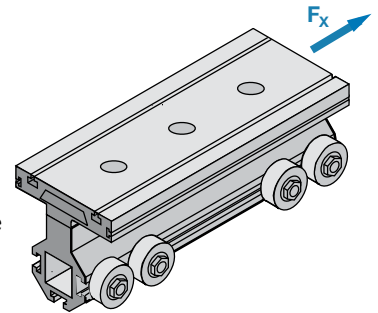

HLE60-RB Load-Bearing Capacity (Fy and Fz)

(Values double for extended carriage)

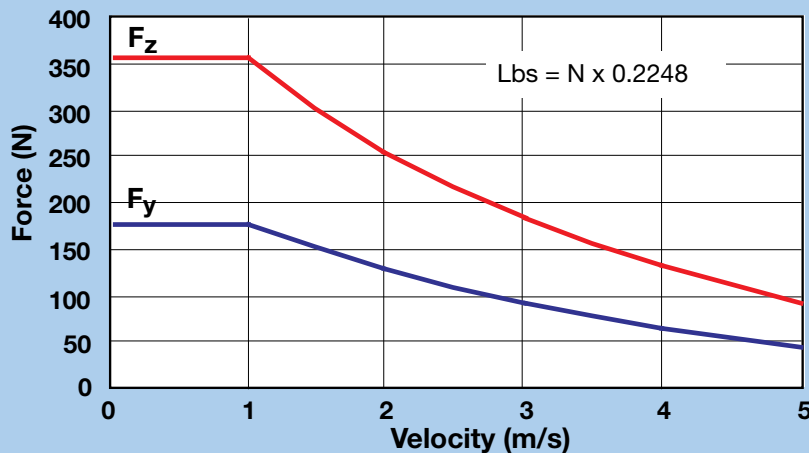

The curves show the maximum load-bearing capacity of a carriage in one direction of force or torque. If several loads are applied in different directions, the values given by the curves must be derated, i.e. the load or speed should be reduced if necessary.

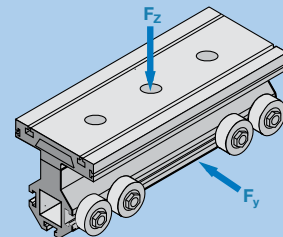

HLE60-RB Maximum Permissible Moment Load (Mx, My and Mz)

(Values double for extended carriage)

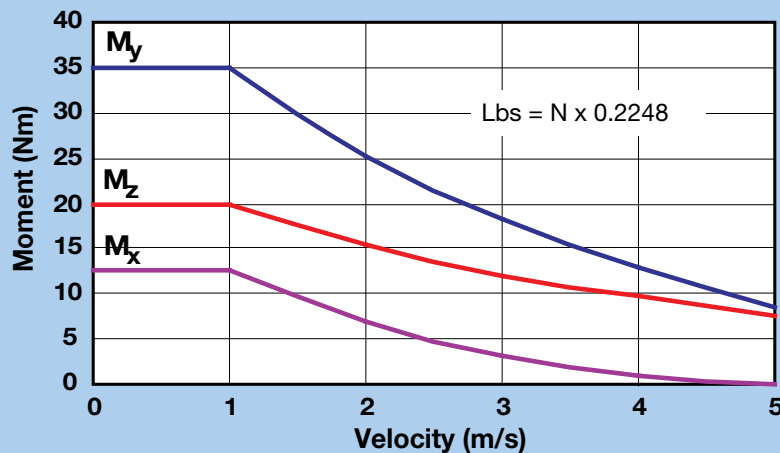

Virtual Engineer software is available for determination of precise carriage loading.



parker.com/VirtualEngineer

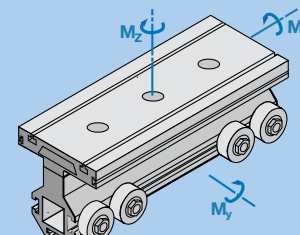

HLE100-RB Series – Load-Bearing Capacity of Carriage and Timing Belt

Load-Bearing Capacity of HLE100 Timing Belt (Fx)

The forces and moments that the carriage is capable of transferring are speed-dependent. The curves shown in the graphs apply to a standard carriage (S). With the extended carriage (E), all the values apart from Fx (load-bearing capacity of timing belt) can be doubled if the load is applied equally to both halves of the carriage or distributed uniformly along its entire length.

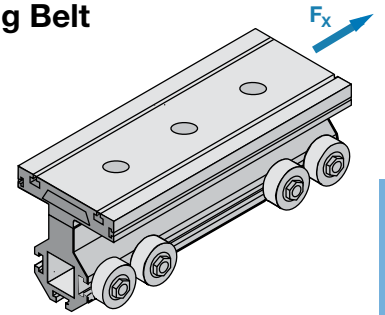

Belt Driven Tables

HLE-100RB

Transferable Thrust Force (n)

Drive Option	Gearhead	Drive Option	Nominal Belt Tension	Maximum Belt Tension
			(81,000 km life)	(46,000 km life)
ARO/ALO	PS90	SP10	675	900
	PX115/PV115	SP11	675	900
	PS115	SP12	925	1115
ARW/ALW/ DAR/DAL	PV90/PX90	SP9	500	675
	PS90	SP10	675	900
	PX115/PV115	SP11	675	900

HLE100-RB Load-Bearing Capacity (Fy and Fz)

(Values double for extended carriage)

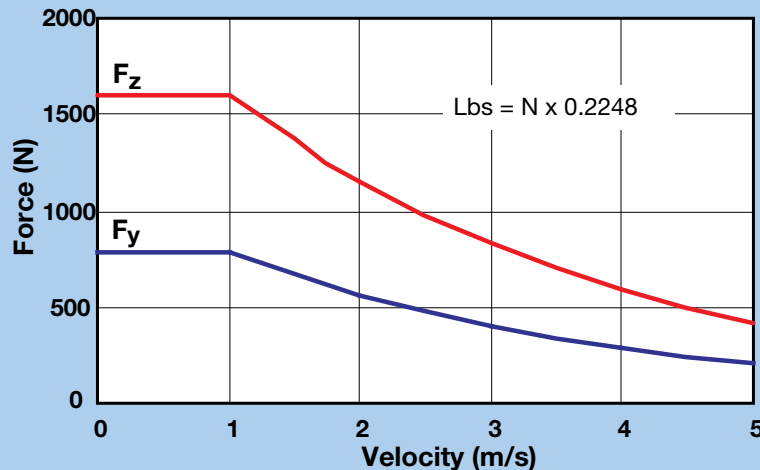

The curves show the maximum load-bearing capacity of a carriage in one direction of force or torque. If several loads are applied in different directions, the values given by the curves must be derated, i.e. the load or speed should be reduced if necessary.

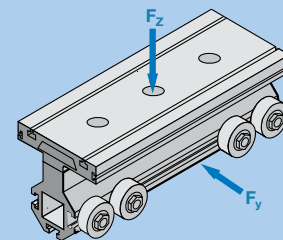

HLE100-RB Maximum Permissible Moment Load (Mx, My and Mz)

(Values double for extended carriage)

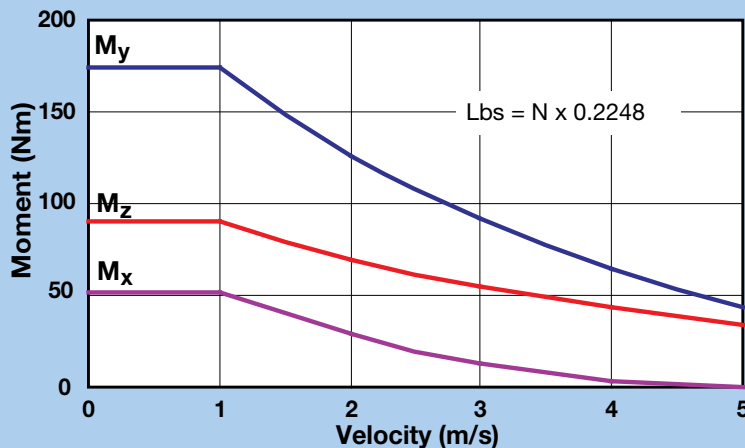

Virtual Engineer software is available for determination of precise carriage loading.



parker.com/VirtualEngineer

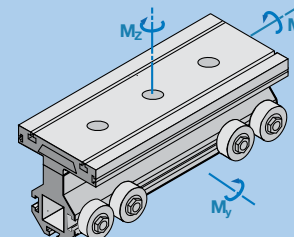

HLE150-RB Series – Load-Bearing Capacity of Carriage and Timing Belt

Load-Bearing Capacity of HLE150 Timing Belt (Fx)

HLE150-RB			Transferable Thrust Force (n)	
Drive Option	Gearhead	Drive Option	Nominal Belt Tension (85,000 km life)	Maximum Belt Tension (37,000 km life)
ARO/ALO	PX115/PV115	SP10	675	900
	PS115	SP11	1515	2015
	PS142	SP12	1700	2235
ARW/ALW/ DAR/DAL	PX115/PV115	SP10	675	900
	PS115	SP11	1515	2015
	PS142	SP12	1700	2235

The forces and moments that the carriage is capable of transferring are speed-dependent. The curves shown in the graphs apply to a standard carriage (S). With the extended carriage (E), all the values apart from Fx (load-bearing capacity of timing belt) can be doubled if the load is applied equally to both halves of the carriage or distributed uniformly along its entire length.

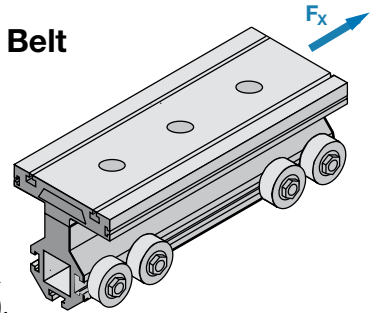

HLE150-RB Load-Bearing Capacity (Fy and Fz)

(Values double for extended carriage)

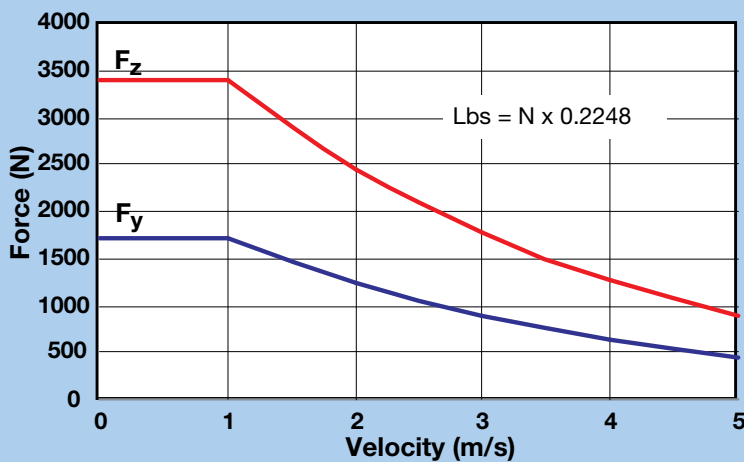

The curves show the maximum load-bearing capacity of a carriage in one direction of force or torque. If several loads are applied in different directions, the values given by the curves must be derated, i.e. the load or speed should be reduced if necessary.

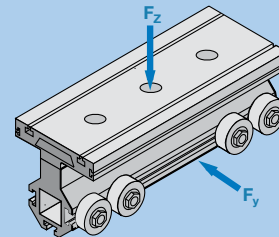

HLE150-RB Maximum Permissible Moment Load (Mx, My and Mz)

(Values double for extended carriage)

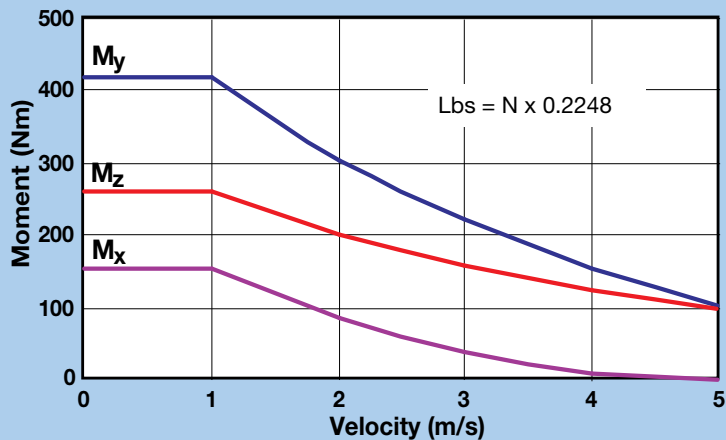

Virtual Engineer software is available for determination of precise carriage loading.



parker.com/VirtualEngineer

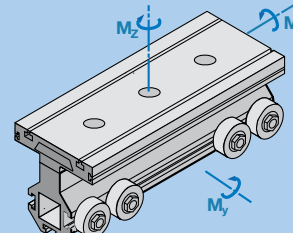

HLE-RB Deflection Characteristics

The HLE deflection curves can be used for determining the deflection based on the profile length and the application load weight. Applications requiring high acceleration forces can place a severe strain on the system stability. In these cases, a solid substructure may be required with the HLE product being supported at frequent intervals.

These deflection curves illustrate the deflection d , based on the HLE profile being simply supported at both ends. The graphs take into consideration the self deflection due to the weight of the profile, along with the load to be transported. The maximum deflection cannot be exceeded. If the maximum deflection is exceeded based on your application parameters, then additional supports are required. Alternatively, the next larger profile size may be considered. For deflection formulae and calculations, please refer to the Technical Information Library found on our web site www.parkermotion.com

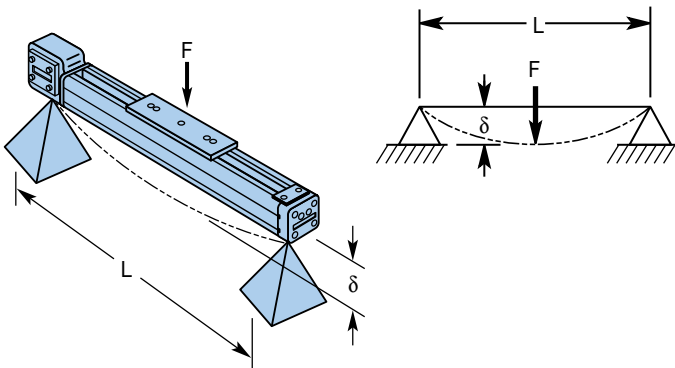

F = Force N
 L = Unsupported length mm
 δ = Deflection mm

Deflection Curves

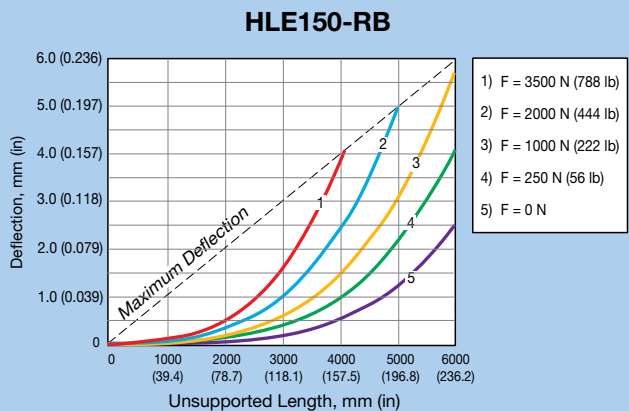
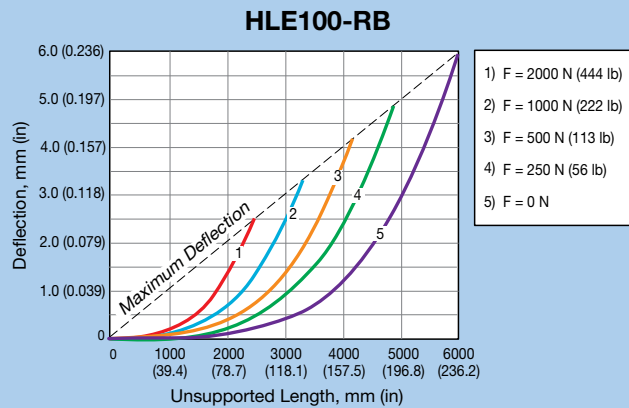
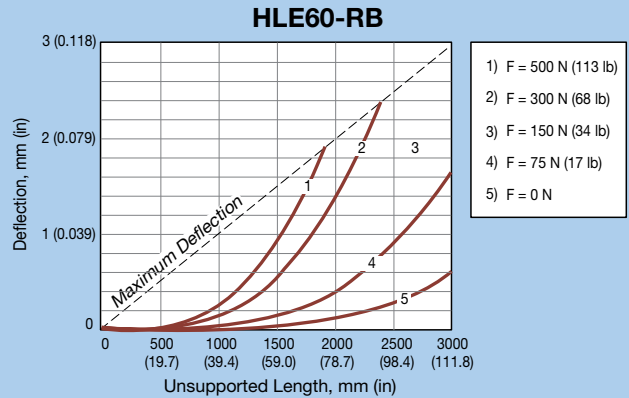

Belt Driven Tables

Dual Unit Axis Considerations

When two parallel linear modules are required to form a single axis, the span or distance between each unit determines which type of shaft connection is required. In some cases, a link shaft support bearing might also be required.

Figure A

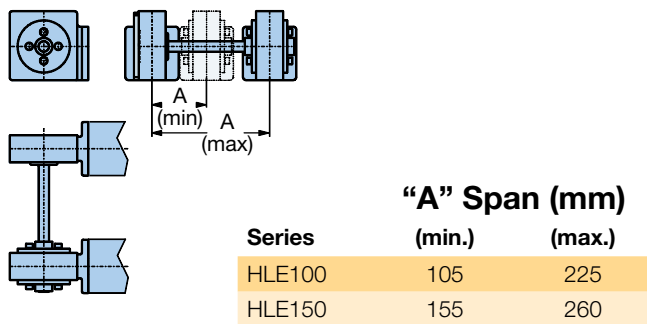

Figure B

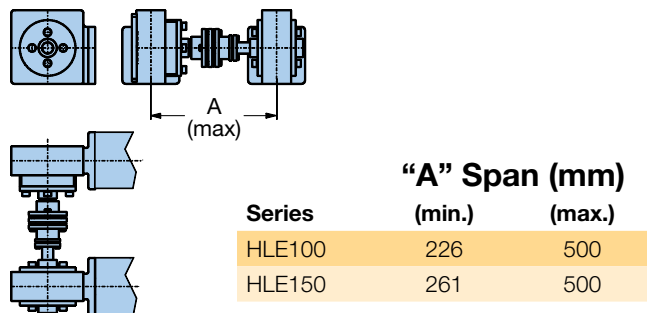
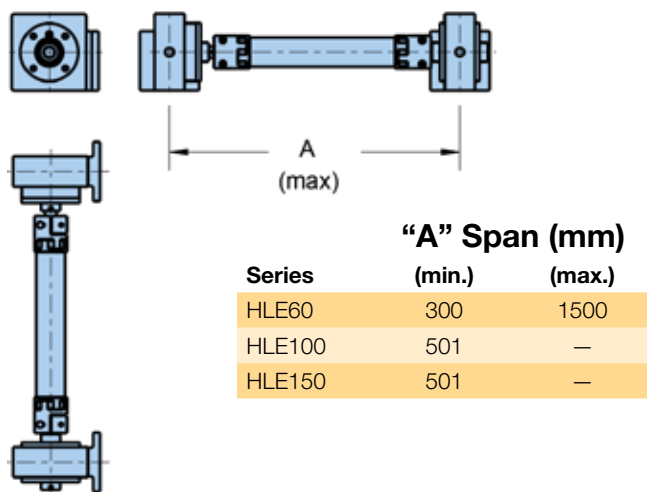
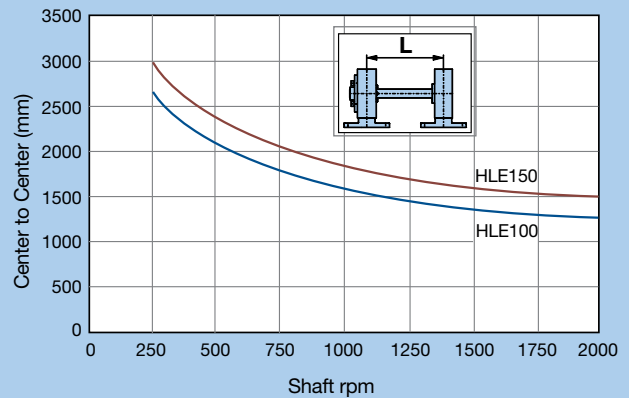

Figure C



The link shaft bearing is used to support the linking shaft of an HLE dual axis when there is a large center to center distance. This bearing must be used if the critical speed is exceeded with the dual-axis link shaft.

Critical Speed*



Linear Velocity

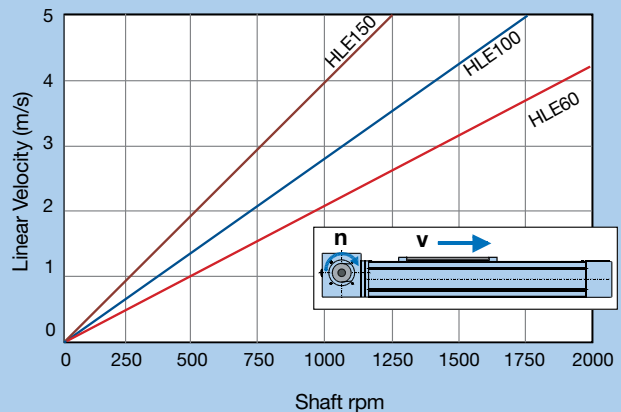

*HLE60 Critical speed is above charted 2000 RPM.

HLE60-RB with PV60 Direct Drive

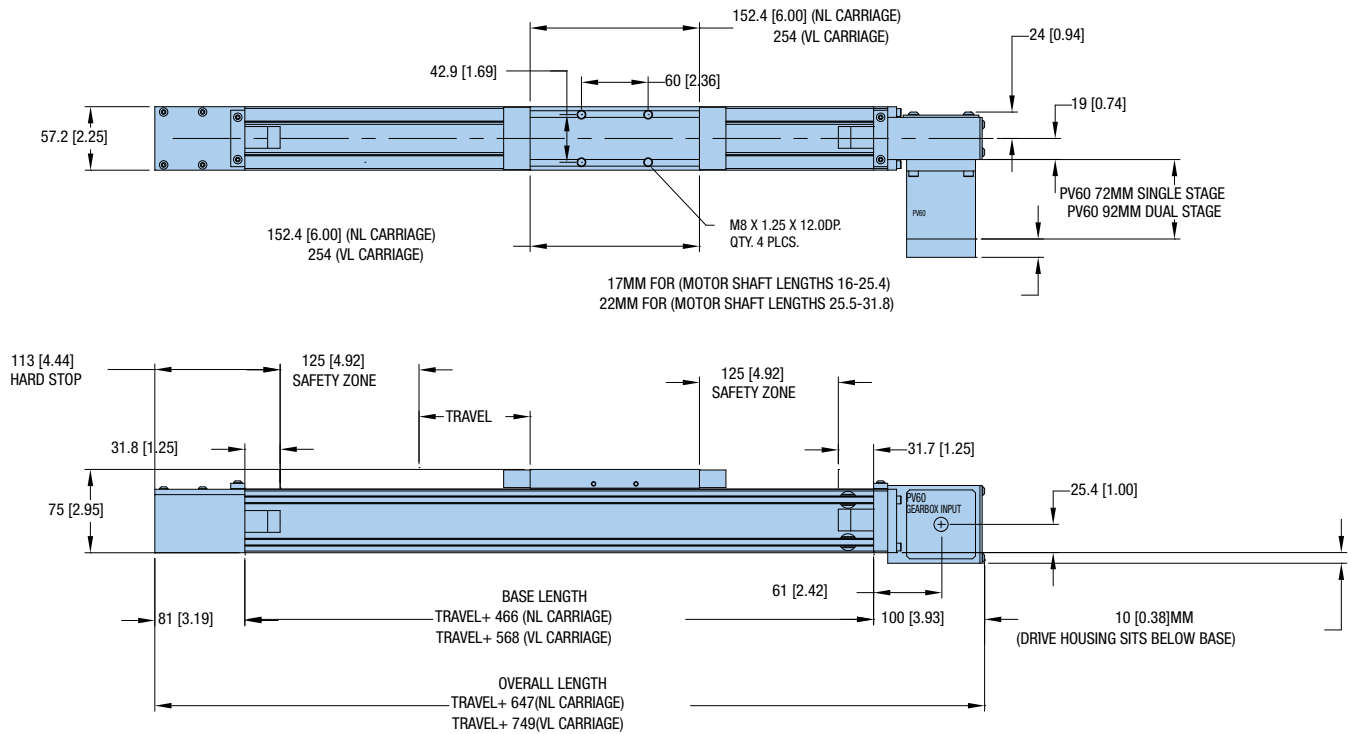

HLE60-RB Drive with Motor Block

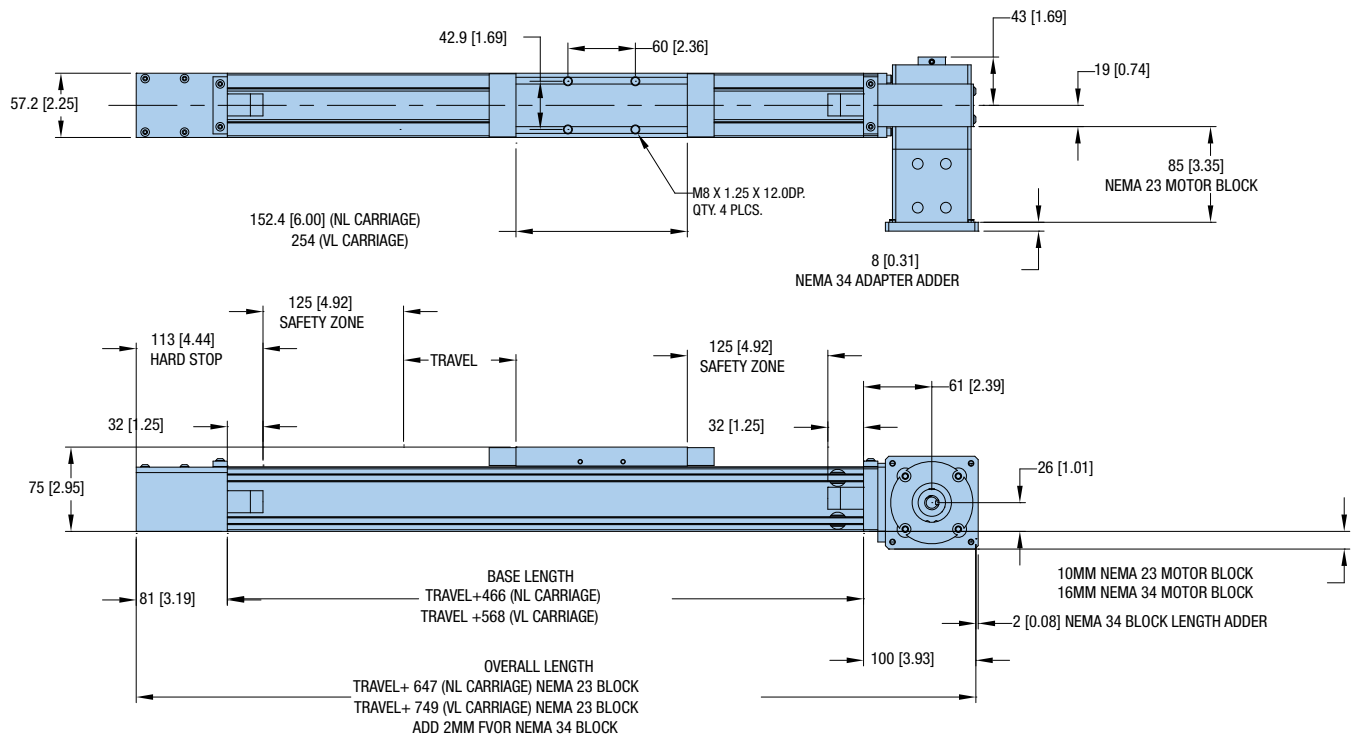

HLE60-RB Idler

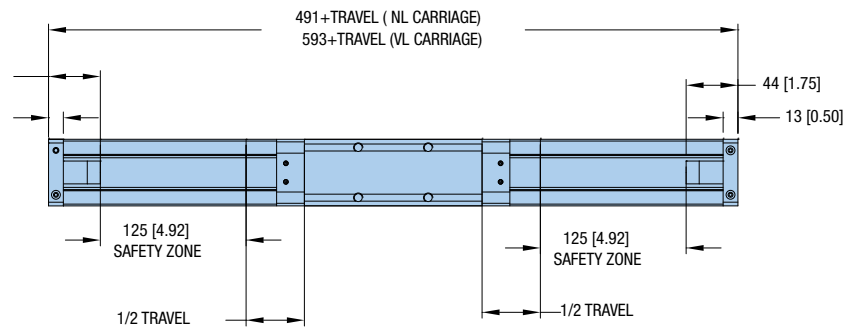

Dimensions (mm)

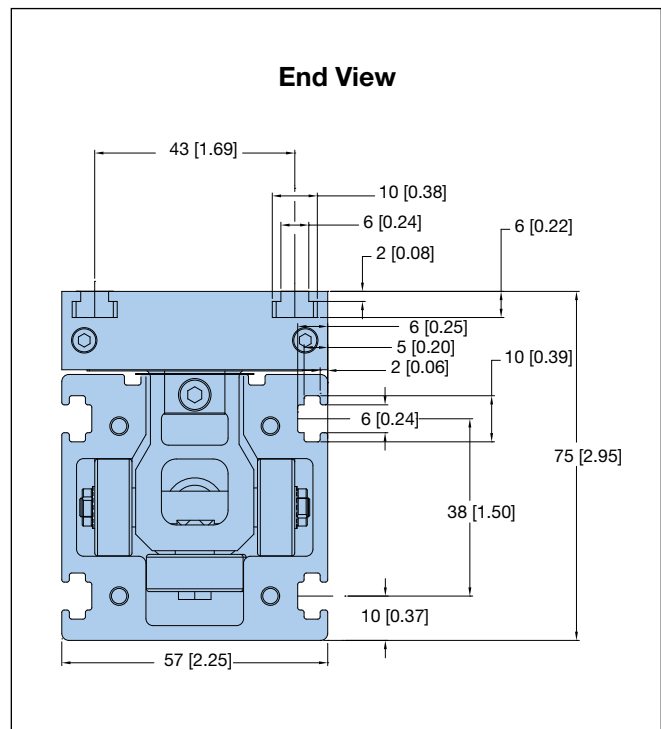
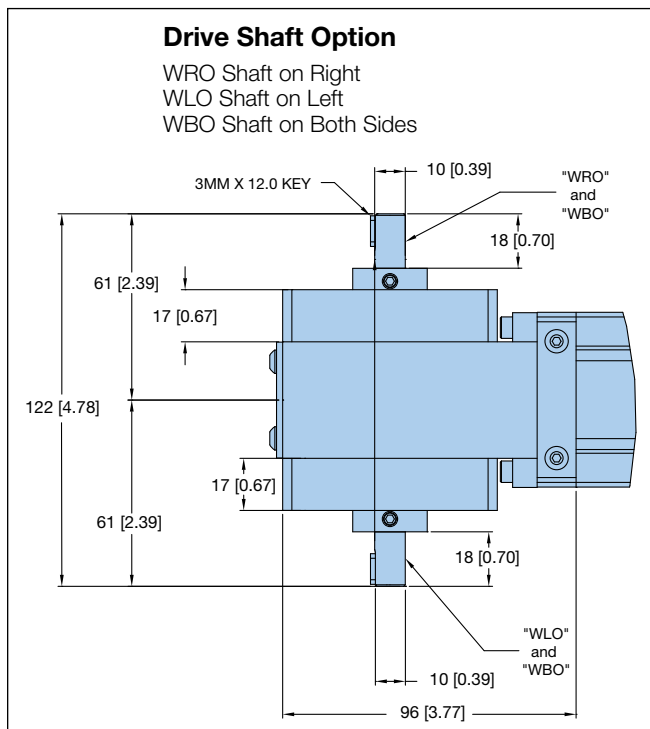

Free sizing and selection support
from Virtual Engineer at
parker.com/VirtualEngineer





HLE100-RB Drive

Dimensions (mm)

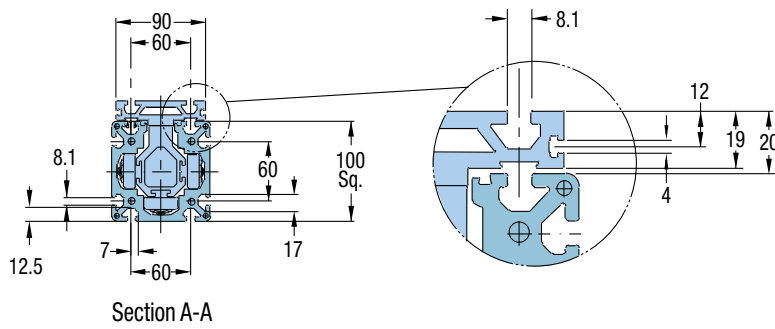
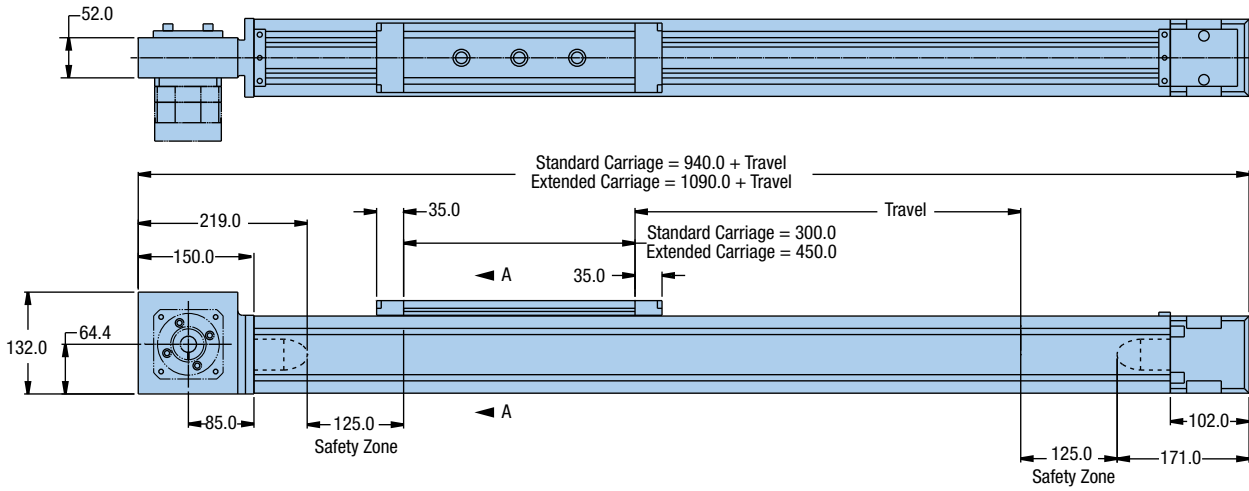

Drive Shaft Option

- WRO Shaft on Right
- WLO Shaft on Left
- WBO Shaft on Both Sides

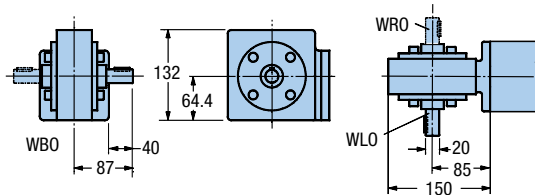

HLE100-RB Idler

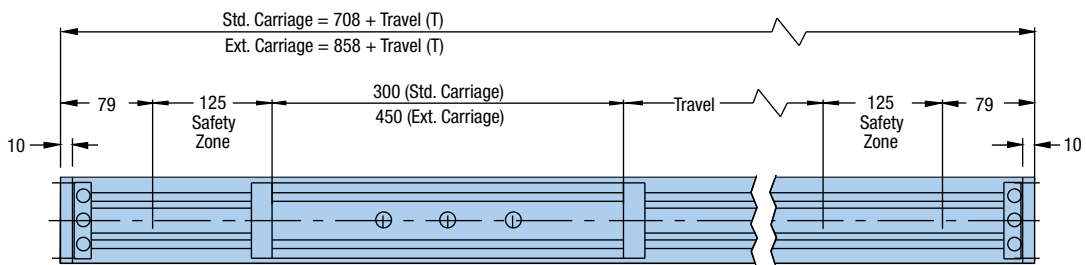

Belt Driven Tables



HLE150-RB Drive

Dimensions (mm)

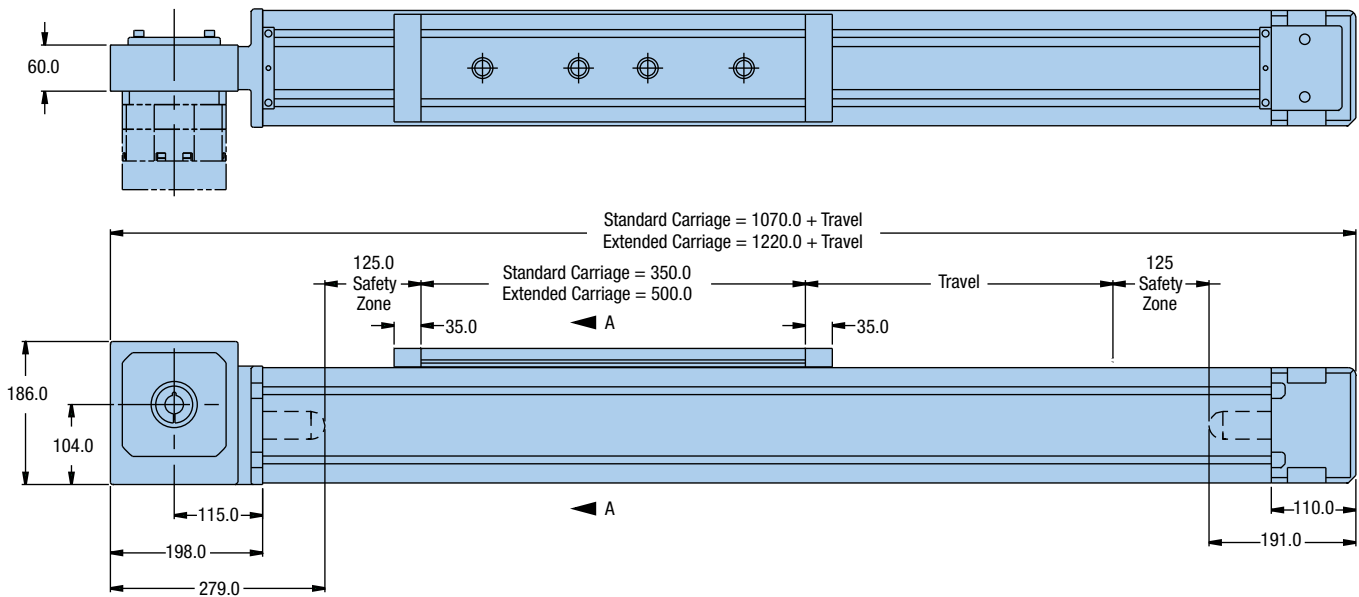

HPLA/HLE OPTIONS & ACCESSORIES
 Limit and home sensors, switches, cable carriers, splice plates, and more.
 See Options & Accessories at the end of the belt-driven section.

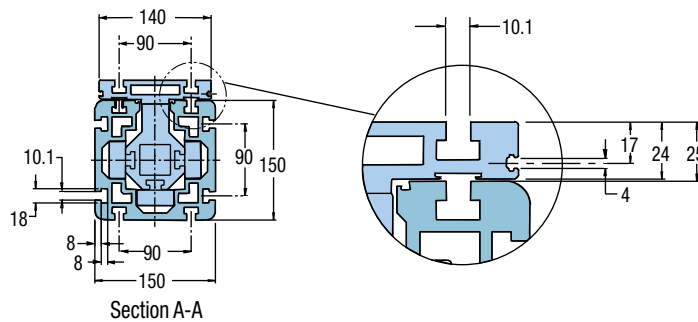

Drive Shaft Option

- WRO Shaft on Right
- WLO Shaft on Left
- WBO Shaft on Both Sides

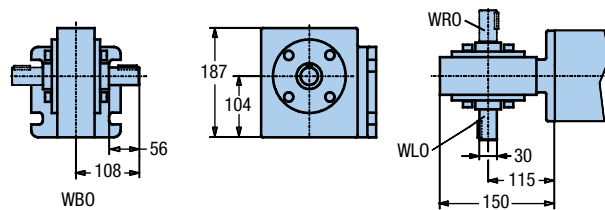

HLE150-RB Idler

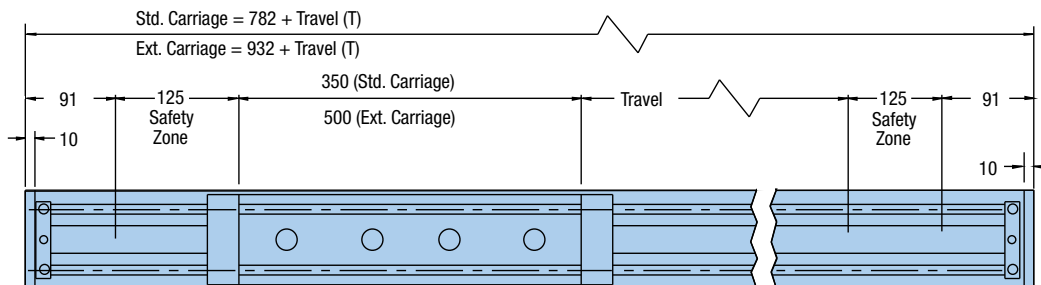

ORDERING INFORMATION

Fill in an order code from each of the numbered fields to create a complete model order code.

- ① ② ③ ④ ⑤ ⑥ ⑦ ⑧ ⑨ ⑩ ⑪ ⑫ ⑬

Order Example: HLE060 RB NL E 1000 DA0000 MBL SP5 G1205 H1 K24 ZA LH0

- ① **Series**
HLE060
- ② **Bearing Type**
RB
- ③ **Carriage Type**
NL Standard Carriage
VL Extended Carriage
- ④ **Unit Type**
M Idler
D Dual Axis Unit
E Single Axis Unit
- ⑤ **Travel Length**
nnnn nnnn=mm (3000 mm max for NLcarriage;
2900 mm max for VL carriage)
- ⑥ **Drive Shaft Option - Center to Center**
DA0000 No Drive Shaft - Single Axis or Idler Unit
DAnnnn (nnnn=mm) Dual Axis Center to Center
(200 mm min; 1500 mm max)
DCnnnn (nnnn=mm) Dual Axis with Covered Link Shaft Center
to Center (200 mm min; 1500 mm max)
- ⑦ **Shaft Configuration Options**
WOO No Shaft, Idler Unit
ARO Gearhead Right
ALO Gearhead Left
ARW Gearhead Right Shaft Left
ALW Gearhead Left Shaft Right
WLO Shaft Left
WRO Shaft Right
WBO Double Shaft
MBL Motor Block Left
MBR Motor Block Right
MLW Motor Block Left, Shaft Right
MRW Motor Block Right, Shaft Left
DAL Double Axis Gearhead, Drive Left
DAR Double Axis Gearhead, Drive Right
DML Double Axis, Motor Block Left
DMR Double Axis, Motor Block Right

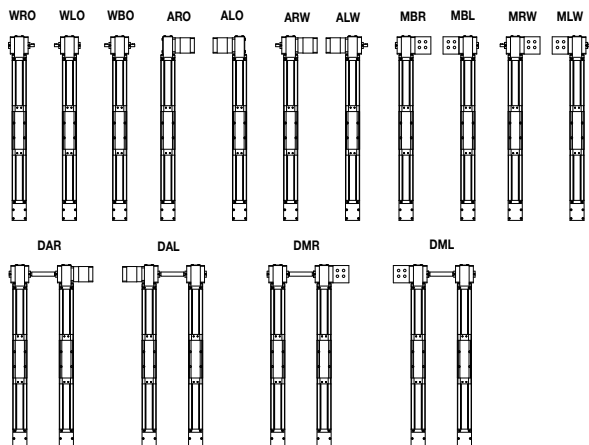

- ⑧ **Drive Station Interface**
SP19 Drive Housing For PV60-FN
SP20 Idler Unit
SP21 No Motor Block
SP22 Motor Block NEMA 23 with 0.375" Bore Coupling
SP23 Motor Block NEMA 34 with 0.25" Bore Coupling
SP24 Motor Block NEMA 34 with 0.375" Bore Coupling
SP25 Motor Block NEMA 34 with 0.50" Bore Coupling
SP28 Motor Block NEMA 23 without Coupling
SP29 Motor Block NEMA 34 without Coupling
SP30 Motor Block Neo 70 with 11.0 mm Bore Coupling

- ⑨ **Gearbox Option***
G0 No Gearbox (Requires MBR, MBL, MRW, MLW)
G1 Customer Supplied Gearhead*
G1203 PV60 Gearhead 3:1 Ratio
G1205 PV60 Gearhead 5:1 Ratio
G1210 PV60 Gearhead 10:1 Ratio
G1215 PV60 Gearhead 15:1 Ratio
G1225 PV60 Gearhead 25:1 Ratio

*Contact factory for approval of any alternative gearbox information.

- ⑩ **Mounting Orientation**
H1 Carriage Up
H2 Carriage Down
H3 Carriage on Side, Drive Station Up
H4 Carriage on Side, Drive Station Down

- ⑪ **Motor Kit Option**
K00 No Motor Kit
K21 Motor Kit LV23, HV23, OS23, ES23, VS23 to PV60
K22 Motor Kit BE23X to PV60
K23 Motor Kit SM23, SE23 to PV60
K24 Motor Kit LV34, HV34
K25 Motor Kit BE34, NO34X, JO34X, TS31, TS32 to PV60
K26 Motor Kit RS34, ES34 to PV60
K27 Motor Kit NO70, JO70 to PV60
K28 Motor Kit SMB60 to PV60

- ⑫ **Strip Seal Option**
ZA Unit with Strip Seal (IP30)
ZB Unit without Strip Seal
- ⑬ **Limit/Home Switch Option**
LH0 No Limit Switch Assembly
LH3 Three NPN Prox Switches, 10-30 VDC
LH4 Three PNP Prox Switches, 10-30 VDC

Belt Driven
Tables

Fill in an order code from each of the numbered fields to create a complete model order code.

① ② ③ ④ ⑤ ⑥ ⑦ ⑧ ⑨ ⑩ ⑪ ⑫ ⑬

Order Example: HLE100 RB NL E 1000 DA0000 ARO SP7 G2-05 H2 ZB K6 LH0

- ① **Series**
HLE100
- ② **Bearing Type**
RB
- ③ **Carriage Type**
NL Standard Carriage
VL Extended Carriage
- ④ **Unit Type**
M Idler
D Dual Axis Unit
E Timing Belt Drive, Nominal Thrust, Maximum Life
- ⑤ **Travel Length**
nnnn Specified travel in mm (nnnn = mm)
- ⑥ **Drive Shaft Option - Center to Center**
DA0000 No Drive Shaft - Single Axis or Idler Unit
DAnnnn (nnnn=mm)
- ⑦ **Shaft Configuration Options**
WOO No Shaft, Idler Unit
WLO Shaft Left
WRO Shaft Right
WBO Double Shaft
ALO Reducer Left
ARO Reducer Right
ALW Reducer Left, Shaft Right
ARW Reducer Right, Shaft Left
DAL Double Axis, Drive Left
DAR Double Axis, Drive Right
MBL Motor Block Left
MBR Motor Block Right
- ⑧ **Drive Station Interface**
SP0 Idler or Shaft Option
SP3 Motor Block - NEMA 34 with 0.500 in. coupling
SP4 Motor Block - NEMA 34 with 0.375 in. coupling

- SP5 Motor Block - NEMA 34 without coupling
- SP6 Motor Block - with coupling for JO923 direct drive
- SP7 Motor Block - NEMA 42 with 0.625 in. coupling
- SP8 Motor Block - NEMA 42 without coupling
- SP9 Drive Housing for PX90/PV90/PEN/PER-090
- SP10 Drive Housing for PS90
- SP11 Drive Housing for PX115/PV115
- SP12 Drive Housing for PS115
- ⑨ **Gearbox Option**
G0-00 No Gearbox
G10-nn PS90
G11-nn PX115
G12-nn PS115
G13-nn PX90
G14-nn PV90
G15-nn PV115
nn = ratio
Single stage ratios 3:1, 5:1, 10:1 Dual stage ratios 15:1, 25:1
- ⑩ **Mounting Orientation**
H1 Carriage Up
H2 Carriage Down
H3 Carriage on Side, Drive Station Up
H4 Carriage on Side, Drive Station Down
- ⑪ **Strip Seal Option**
ZA Unit with Strip Seal (IP30)
ZB Unit without Strip Seal
- ⑫ **Motor Kit Option**
K0 No motor kit
K1 J034*, N034*, BE34*, TS31, TS32 to GT-090, PE-090
K2 J070*, N070* to GT-090, PE-090
K3 J090*, N090* to GT-090, PE-090
K4 M105* to GT-090, PE-090
K5 ES3*, OEM83-*, ZETA83-*, S83-*, RS3* to GT-090, PE-090
K6 J034*, N034*, BE34*, TS3
K7 J090*, N090*
K8 M105*
K9 ES3*, OEM83-*, ZETA83-*, S83-*, RS3*
K10 RS42, RE42, S106-205
K11 S106-178, S106-250
K12 M145
K35 Parker MPP092/MPJ092
K37 Parker MPP100/MPJ100
K39 Parker MPP115/MPJ115
K41 Parker MPP142/MPJ142
K50 Parker HDY55; MPL15XX (Allen Bradley)
K51 AKM3X-AN (Kollmorgen)
K52 SGMAH-04 (Yaskawa)
K53 SGMAH-08 (Yaskawa)
K54 MKD041 (Indramat)
K55 AKM4X-AN (Kollmorgen)
K56 MKD070 (Indramat)
- ⑬ **Limit/Home Switch Option**
LH0 No Limit Switch Assembly
LH3 Three NPN Prox Switches, 10-30 VDC
LH4 Three PNP Prox Switches, 10-30 VDC

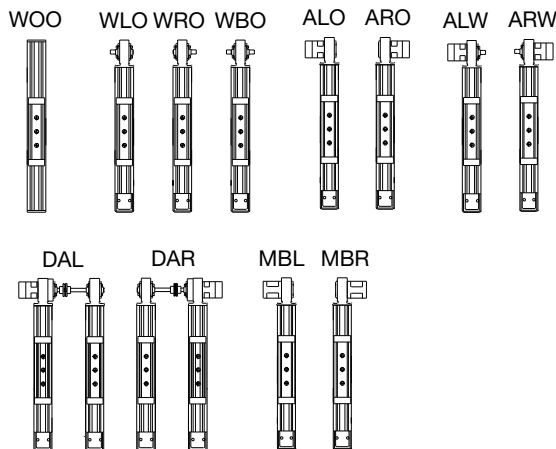

Free sizing and selection support
from Virtual Engineer at
parker.com/VirtualEngineer



Fill in an order code from each of the numbered fields to create a complete model order code.

① ② ③ ④ ⑤ ⑥ ⑦ ⑧ ⑨ ⑩ ⑪ ⑫ ⑬

Order Example: HLE150 RB NL E 1000 DA0000 ARO SP1 G2-05 H2 ZA K7 LH2

- ① **Series**
HLE150
- ② **Bearing Type**
RB
- ③ **Carriage Type**
NL Standard Carriage
VL Extended Carriage
- ④ **Unit Type**
M Idler
E Timing Belt Drive, Nominal Thrust, Maximum Life
F Timing Belt Drive, Maximum Thrust, Nominal Life
- ⑤ **Travel Length**
nnnn Specified travel in mm (nnnn = mm)
- ⑥ **Drive Shaft Option - Center to Center**
DA0000 No Drive Shaft - Single Axis or Idler Unit
DAnnnn (nnnn=mm)
- ⑦ **Shaft Configuration Options**
WOO No Shaft, Idler Unit
WLO Shaft Left
WRO Shaft Right
WBO Double Shaft
ALO Reducer Left
ARO Reducer Right
ALW Reducer Left, Shaft Right
ARW Reducer Right, Shaft Left
DAL Double Axis, Drive Left
DAR Double Axis, Drive Right

- ⑧ **Drive Station Interface**
SP0 Idler or Shaft Option
SP10 Drive Housing for PX115/PV115
SP11 Drive Housing for PS115
SP12 Drive Housing for PS142
- ⑨ **Gearbox Option**
G0-00 No Gearbox
G10-*nn* PX115
G11-*nn* PS115
G12-*nn* PS142
G13-*nn* PX90
G15-*nn* PV115
nn = ratio
Single stage ratios 3:1, 5:1, 10:1 Dual stage ratios 15:1, 25:1
- ⑩ **Mounting Orientation**
H1 Carriage Up
H2 Carriage Down
H3 Carriage on Side, Drive Station Up
H4 Carriage on Side, Drive Station Down
- ⑪ **Strip Seal Option**
ZA Unit with Strip Seal (IP30)
ZB Unit without Strip Seal
- ⑫ **Motor Kit Option**
K0 No motor kit
K11 S106-178, S106-250 TO GT-115, PE-115
K12 M145 TO GT-115, PE-115
K13 M145 TO GT-142, PE-142
K35 PARKER MPP092/MPJ092
K37 PARKER MPP100/MPJ100
K39 PARKER MPP115/MPJ115
K41 PARKER MPP142/MPJ142
K50 PARKER HDY55; MPL15XX (ALLEN BRADLEY)
K51 AKM3X-AN (KOLLMORGEN)
K52 SGMAH-04 (YASKAWA)
K53 SGMAH-08 (YASKAWA)
K54 MKD041 (INDRAMAT)
K55 AKM4X-AN (KOLLMORGEN)
K56 MKD070 (INDRAMAT)
K57 MKD090 (INDRAMAT)
*SINGLE STAGE RATIOS: 3, 5, 8, 10; DUAL STAGE RATIOS: 12, 15, 16, 20, 25
- ⑬ **Limit/Home Switch Option**
LH0 No Limit Switch Assembly
LH3 Three NPN Prox Switches, 10-30 VDC
LH4 Three PNP Prox Switches, 10-30 VDC

Belt Driven Tables

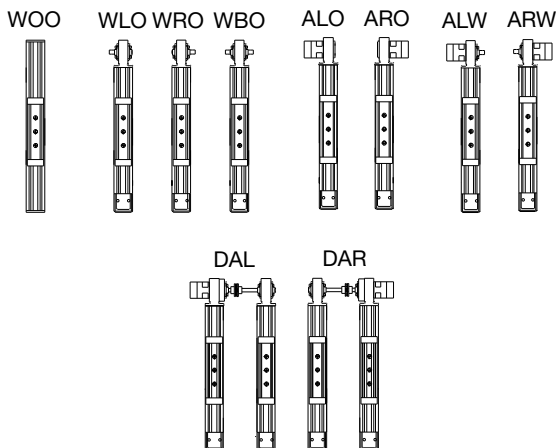

HLE-SR Series Belt Driven Linear Modules

Belt-Drive Actuators for High Thrust, Long Stroke Applications

- Low running friction
- Low wear and low maintenance
- Quiet operation
- High efficiency
- Long service life
- High dynamic performance due to high load capacity square rail systems



Proven Technology

- Easily accessible lubrication points
- Minimal preventive maintenance required
- T-slots integrated on sides of the profile for mounting attachments or for use as a cable duct
- Timing belts can be replaced without removing load attachment plate
- Multiple configuration options due to T-slots available on both the profile and load plate

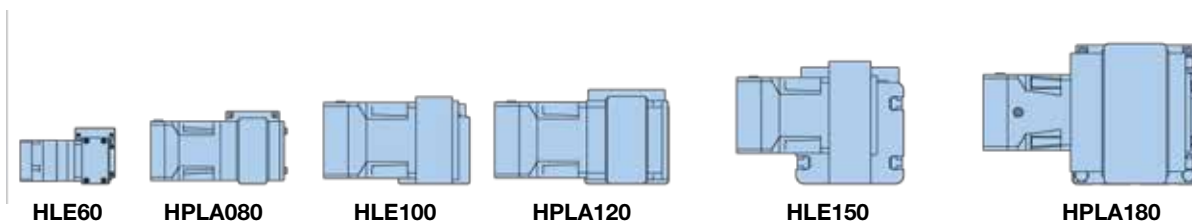

	HLE60	HPLA80	HLE100	HPLA120	HLE150	HPLA180
Maximum Travel (mm)	4,000	5,540	6,200	9,470	7,900	9,240
Maximum Payload (N)	353	1,304	1,549	2,598	3,402	4,501
Maximum Acceleration (m/s²)	10	10	10	10	10	10

*Do not exceed allowable axial and moment loading.

HLE-SR Bearing System

The bearing system is the principal distinction between the RB (Roller Bearing) type modules and the SR (Square Rail) type. The SR employs a square rail bearing system, which permits greater load carrying capability without increasing overall size. Square

rail bearings are recirculating ball bearings designed to move heavy loads on a precise linear path. Linear guides, which house several rows of re-circulating ball bearings, ride on a high strength, steel square rail. The steel square rail cross section enables bearing ways to be ground into the

sides of the rail. These bearing ways are shaped in an arch which approximates the same radius as the ball bearing. This increases the contact surface between the ball and the rail, thereby increasing the load capacity of the linear bearing.

HLE-SR Drive Principle

The HLE-SR employs the same high performance belt and pulley drive mechanism as the HLE-RB. It features a zero backlash steel reinforced timing belt drive,

which provides high speeds, high acceleration, and good bidirectional repeatability. A belt tension station, conveniently located at the end of the unit provides for quick and easy

belt adjustment. The drive station is designed to accept planetary gear reducers as well as a wide variety of servo and stepper motors.

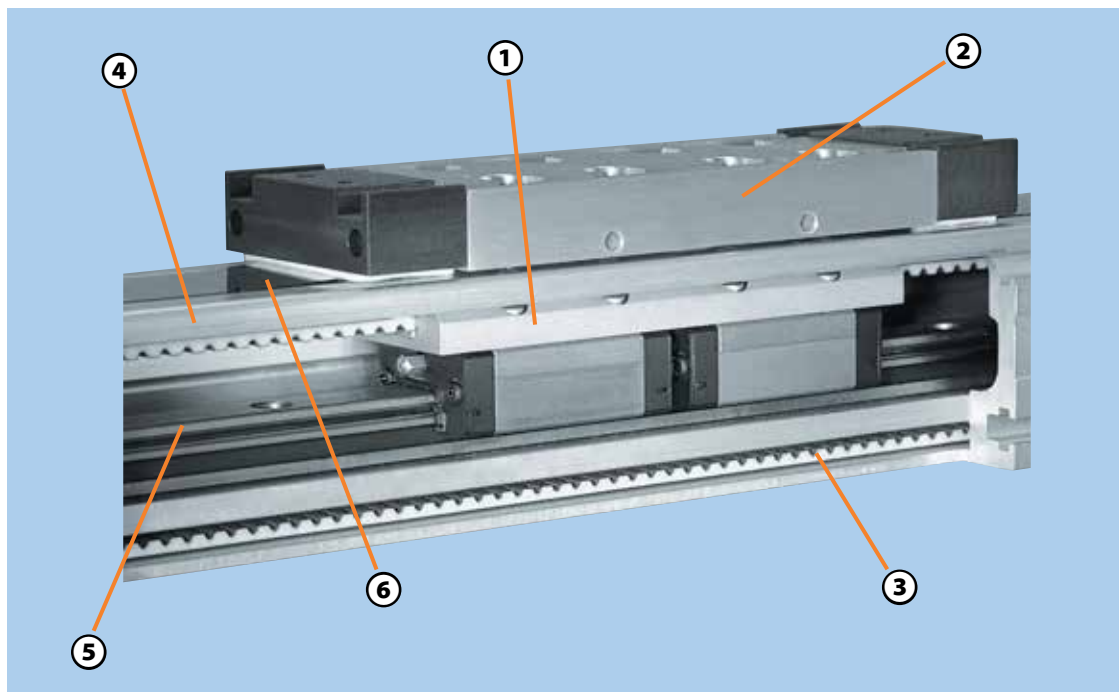

- 1 Carriage**

A rigid carriage assembly is built upon two bearing housings which contain several rows of recirculating ball bearings designed to ride in grooves ground into a steel square rail linear raceway. Longer or custom carriages are also available.

Load Attachment Plate

Longitudinal T-Slots integrated on the top of this plate facilitate the assembly of attachments to the HLE-SR. Utilization of these T-Slots together with standard clamping profiles enables easy straight-forward construction of multi-axis systems.
 - 2 Drive Belt**

A zero backlash, steel reinforced timing belt provides high speed, high acceleration and high bidirectional repeatability. A serrated clamp mechanism between belt and carriage guarantees a safe and strong connection.
 - 3 Housing**

The HLE-SR housing is a light-weight, compact and self-supporting extruded aluminum section. It is available in two cross-sections: 60 x 60 mm (HLE60) and 100 x 100 mm (HLE100). T-slots along the length are utilized for clamping mechanical components, joining units, and attaching sensors or mechanical switches.
 - 4 Bearing Raceway**

A high strength steel alloy bearing rail features precision ground “gothic arch” raceways to provide precise translation and high strength support of the recirculating ball bearings.
 - 5 Optional IP30 Strip Seal**

Magnetically attached stainless steel seal strip provides environmental protection to interior components.
- Optional Features**
- Direct mounting for planetary gear reducers
 - Adjustable “end of travel” limit switches and “Home” position sensor
 - Cable carrier systems
 - Performance matched Parker servo systems
 - Structural components for vertical and multi-axis mounting
 - Toe clamps and hardware for fast/easy mounting
 - External bumpers
 - Link shafts and support bearing for dual unit axes
 - Splice plates for extending travels beyond length available in a single profile

SPECIFICATIONS

As part of the advanced, cost-effective construction of machines and handling systems, the HPLA is a good choice for applications such as materials handling (palletizing, depalletizing, feeding, and part removal), warehouse technology (parts picking, storage and retrieval), and machine tool automation (workpiece loading and unloading, tool changing). Additional examples include textile machinery building (cross-cutting, slitting and stacking, quilting, seam stitching) and construction (formwork and placing reinforcing steel bars in concrete).



Other typical applications are process engineering (painting, coating, bonding), testing technology (guiding ultrasonic sensors, laboratory equipment), and cleanroom technology (wafer transport, wafer coating).

Characteristic	Units	HLE60-SR		HLE100-SR	
Unit Weight (basic unit without stroke)					
Standard Carriage, NL	kg (lb.)	3.5	(7.7)	16.2	(35.7)
Extended Carriage, VL	kg (lb.)	5.91	(13)	20.0	(44.1)
Carriage Weight					
Standard Carriage, NL	kg. (lb)	1.8	(4.0)	2.2	(4.9)
Extended Carriage, VL	kg. (lb)	2.1	(4.6)	3.8	(8.4)
Weight per meter of additional length	kg/m (lb/ft)	5.5	(3.7)	13.3	(8.9)
Moment of Inertia (related to the drive shaft)					
Standard Carriage, NL	kg-cm ² (lb-in ²)	3.52	(1.20)	34.8	(11.9)
Extended Carriage, VL	kg-cm ² (lb-in ²)	5.20	(1.83)	52.2	(17.9)
Travel and Speed					
Maximum Speed ⁽¹⁾	m/s (in/s)	3	(120)	3	(120)
Maximum Acceleration ⁽¹⁾	m/s ² (in/s ²)	10	(393)	10	(393)
Maximum Travel ⁽²⁾ , NL	m (in)	3.05	(120)	6.15	(242)
Maximum Travel ⁽²⁾ , VL	m (in)	2.8	(114)	6.0	(236)
Geometric Data					
Cross Section, Square	mm (in)	57.2	(2.25)	100	(3.94)
Moment of Inertia I _x	cm ⁴ (in ⁴)	48.3	(1.16)	377	(9.06)
Moment of Inertia I _y	cm ⁴ (in ⁴)	59.5	(1.43)	432	(10.38)
Moment of Elasticity	N/mm ² (lb/in ²)	0.72 x 10 ⁵	(0.1044 x 10 ⁶)	0.72 x 10 ⁵	(0.1044 x 10 ⁶)
Pulley Data, Torques, Forces					
Travel Distance per Revolution	mm/rev (in/rev)	125	(4.92)	240.0	(9.45)
Pulley Diameter	mm (in)	39.8	(1.57)	74.5	(2.93)
Maximum Drive Torque ⁽³⁾	Nm (lb-in)	8.87	(79)	61.5	(544)
Maximum Belt Traction ⁽³⁾ (effective load)	N (lb)	668	(150)	1650	(371)
Repeatability ⁽⁴⁾	mm (in)	±0.2	(±0.008)	±0.2	(±0.008)

For the following deviations from the above standards, please contact Parker engineering: (1) Greater speeds and accelerations may be achieved. (2) Splicing possible for longer travel distances. This may cause reductions in effective load, drive torque, speed, acceleration, and repeatability. (3) Increased timing belt tension required. (4) Nominal value - component dependant. For improved repeatability consult factory.

HPLA/HLE OPTIONS & ACCESSORIES

Limit and home sensors, switches, cable carriers, splice plates, and more.

See Options & Accessories at the end of the belt-driven section.

HLE-60SR Series – Load-Bearing Capacity of Carriage and Timing Belt

Load-Bearing Capacity of HLE-60SR Timing Belt (Fx)

Drive Option	Transferrable Thrust Force (n)	
	Nominal Belt Tension (81,000 km life)	Maximum Belt Tension (46,000 km life)
Supported Pulley (SP19 - SP30)	500	–

The forces and moments that the carriage is capable of transferring are speed-dependent. The curves shown in the graphs apply to a standard carriage (S). With the extended carriage (E), all the values apart from Fx (load-bearing capacity of timing belt) can be doubled if the load is applied equally to both halves of the carriage or distributed uniformly along its entire length.

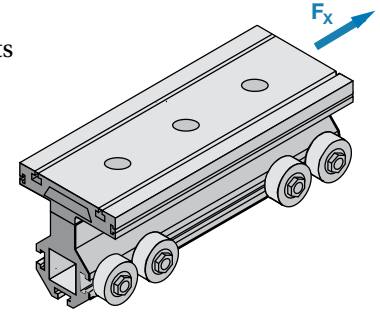

Belt Driven Tables

HLE-60SR Load-Bearing Capacity (Fy and Fz) (Values double for extended carriage)

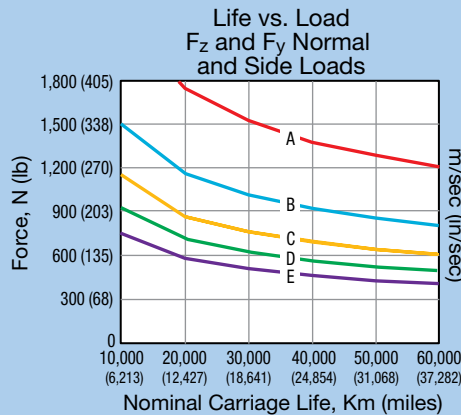

The curves show the maximum load-bearing capacity of a carriage in one direction of force or torque. If several loads are applied in different directions, the values given by the curves must be derated, i.e. the load or speed should be reduced if necessary.

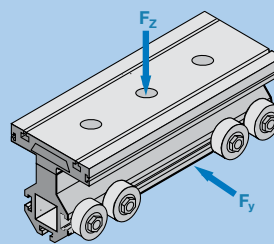

Virtual Engineer software is available for determination of precise carriage loading.

parker.com/VirtualEngineer

HLE-60SR Maximum Permissible Moment Load (Mx, My and Mz) (Values double for extended carriage)

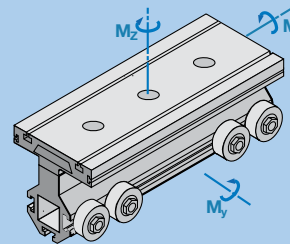

Curve	Velocity	
	m/sec.	(in/sec.)
A	0.25	(10)
B	0.50	(20)
C	1.00	(40)
D	2.00	(80)
E	3.00	(120)

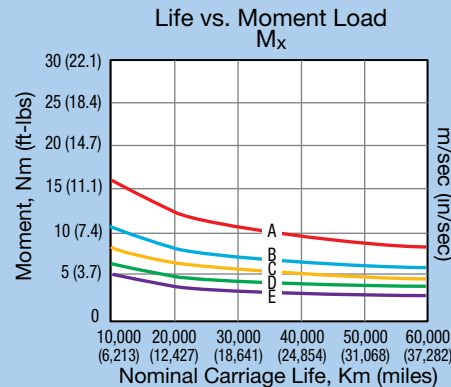
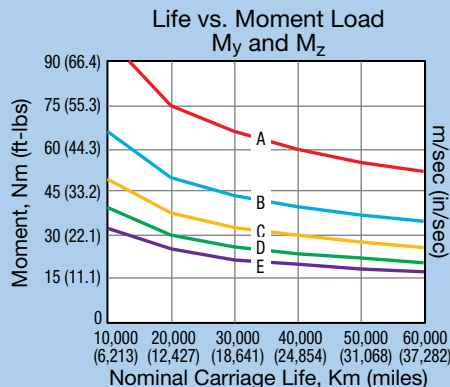

HLE-100SR Series – Load-Bearing Capacity of Carriage and Timing Belt

Load-Bearing Capacity of HLE-100SR Timing Belt (F_x)

Drive Option	Gearhead	Drive Option	Transferrable Thrust Force (n)	
			Nominal Belt Tension (81,000 km life)	Maximum Belt Tension (46,000 km life)
ARO/ALO	PS90	SP10	675	900
	PX115/PV115	SP11	675	900
	PS115	SP12	925	1115
ARW/ALW/ DAR/DAL	PV90/PX90	SP9	500	675
	PS90	SP10	675	900
	PX115/PV115	SP11	675	900

The forces and moments that the carriage is capable of transferring are speed-dependent. The curves shown in the graphs apply to a standard carriage (S). With the extended carriage (E), all the values apart from F_x (load-bearing capacity of timing belt) can be doubled if the load is applied equally to both halves of the carriage or distributed uniformly along its entire length.

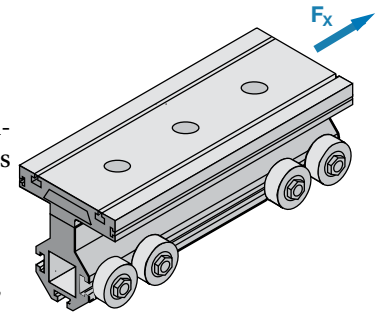

HLE-100SR Load-Bearing Capacity (F_y and F_z) (Values double for extended carriage)

The curves show the maximum load-bearing capacity of a carriage in one direction of force or torque. If several loads are applied in different directions, the values given by the curves must be derated, i.e. the load or speed should be reduced if necessary.

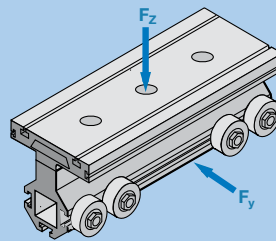
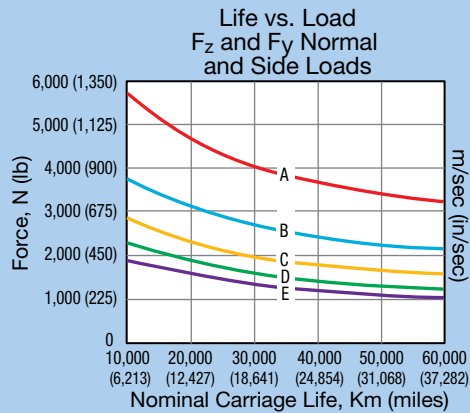

Virtual Engineer software is available for determination of precise carriage loading.

parker.com/VirtualEngineer

HLE-100SR Maximum Permissible Moment Load (M_x , M_y and M_z) (Values double for extended carriage)

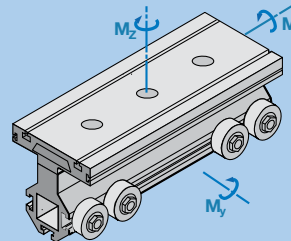

Curve	Velocity	
	m/sec.	(in/sec.)
A	0.25	(10)
B	0.50	(20)
C	1.00	(40)
D	2.00	(80)
E	3.00	(120)

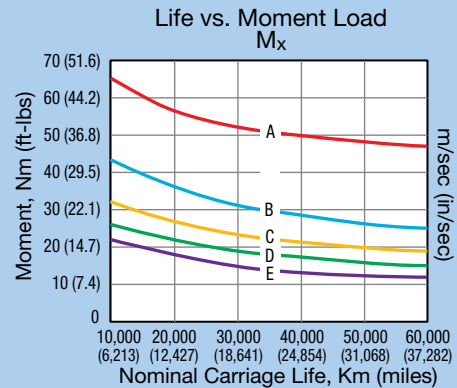
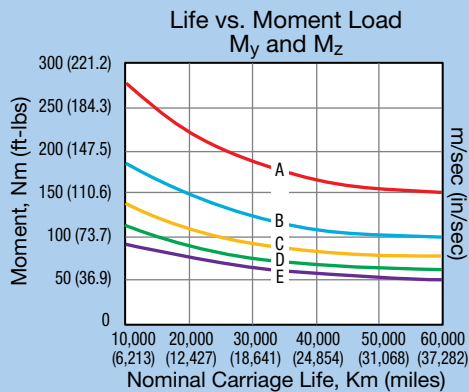

HLE-SR Deflection Characteristics

The HLE deflection curves can be used for determining the deflection based on the profile length and the application load weight. Applications requiring high acceleration forces can place a severe strain on the system stability. In these cases, a solid substructure may be required with the HLE product being supported at frequent intervals.

These deflection curves illustrate the deflection δ , based on the HLE profile being simply supported at both ends. The graphs take into consideration the self deflection due to the weight of the profile, along with the load to be transported. The maximum deflection cannot be exceeded unless additional supports are implemented. Alternatively, the next larger profile size may be considered. For deflection formulas and calculations, please refer to the Technical Information Library found on our web site www.parkermotion.com.

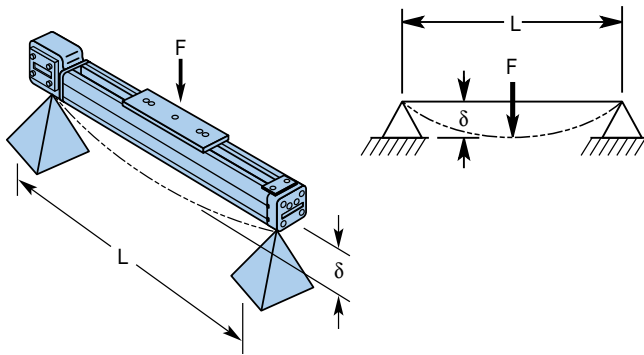

- F = Force N
- L = Unsupported length mm
- δ = Deflection mm

Deflection Curves

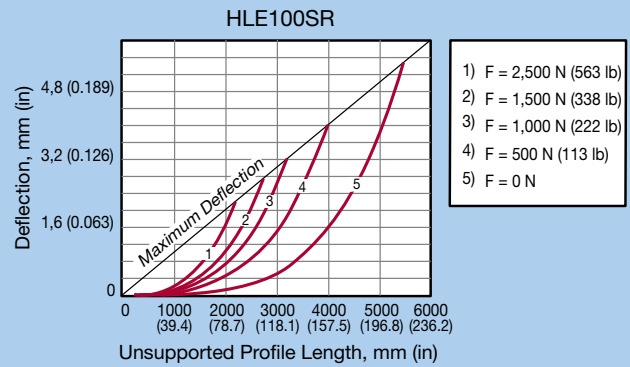
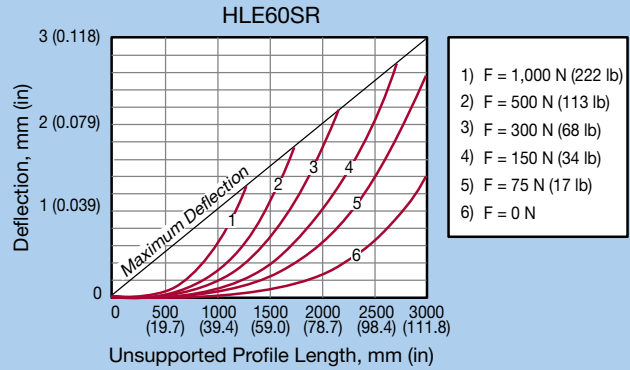

DIMENSIONS

Download 2D & 3D files from
www.parker.com/emn/HLE60-SR



DIMENSIONS

HLE60-SR with PV60 Direct Drive

Dimensions (mm)

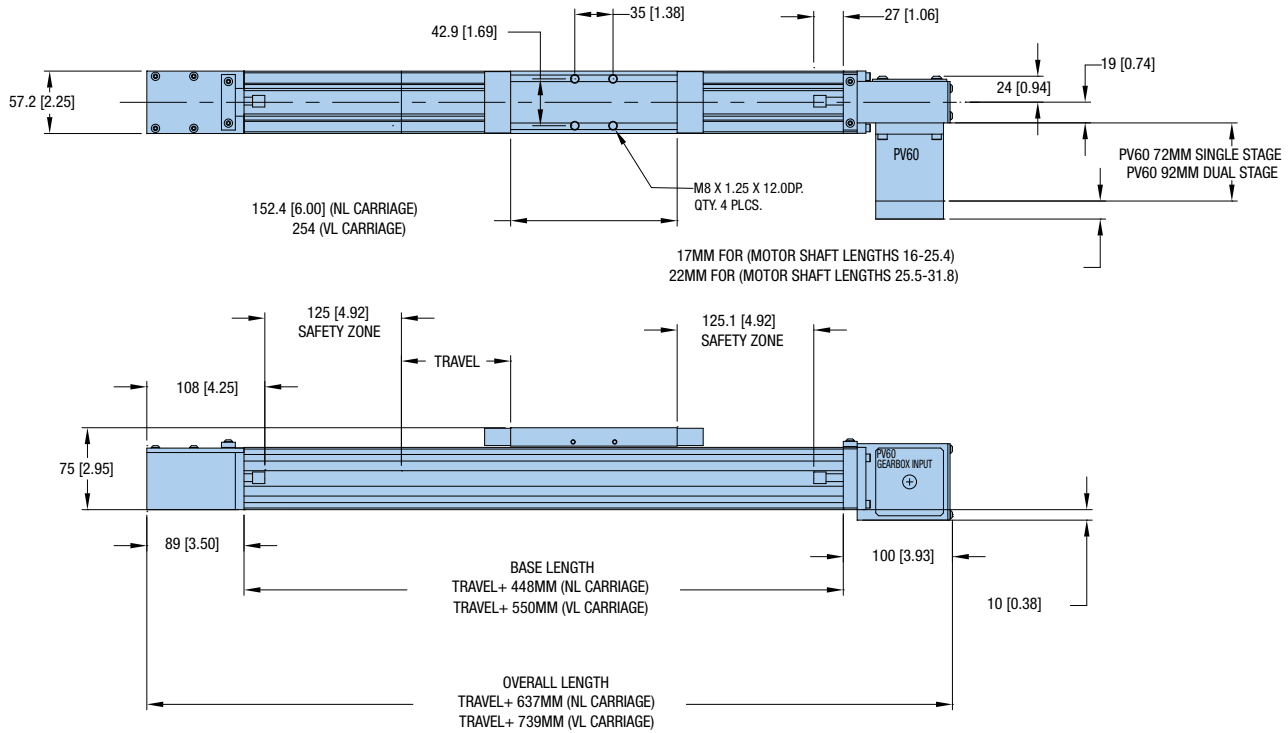

HLE60-SR Drive with Motor Block

Dimensions (mm)

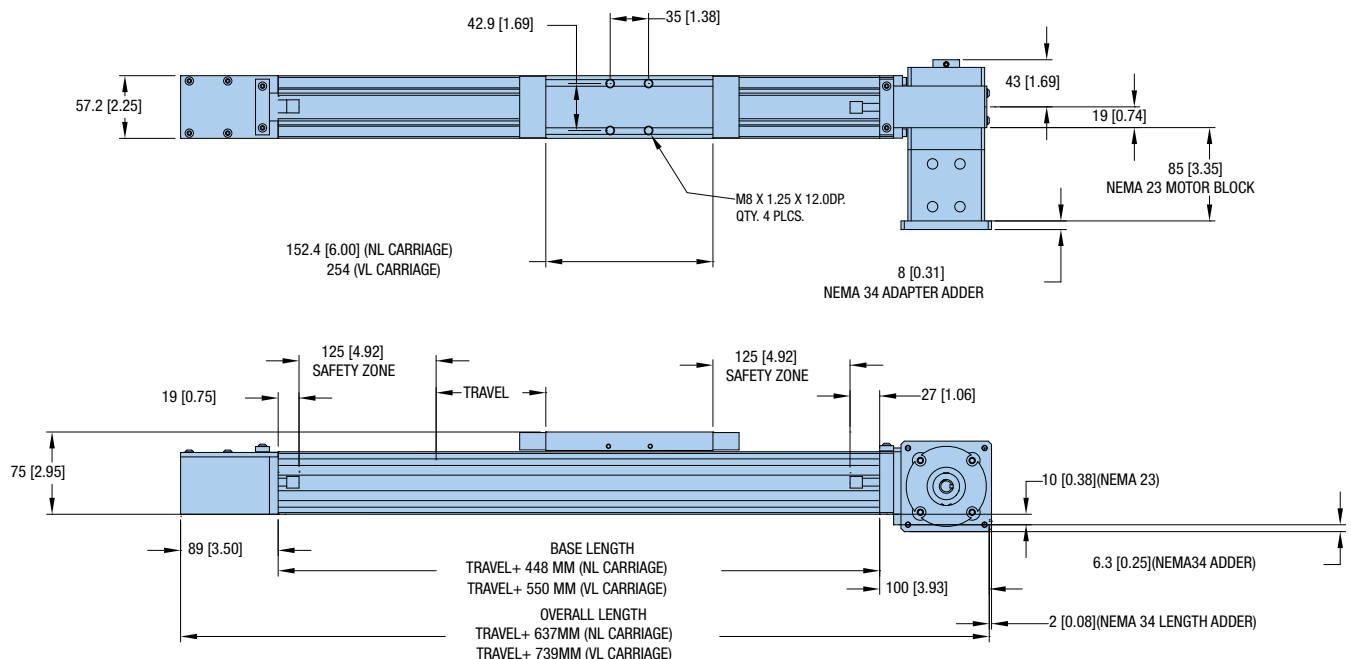



HLE60-SR Idler

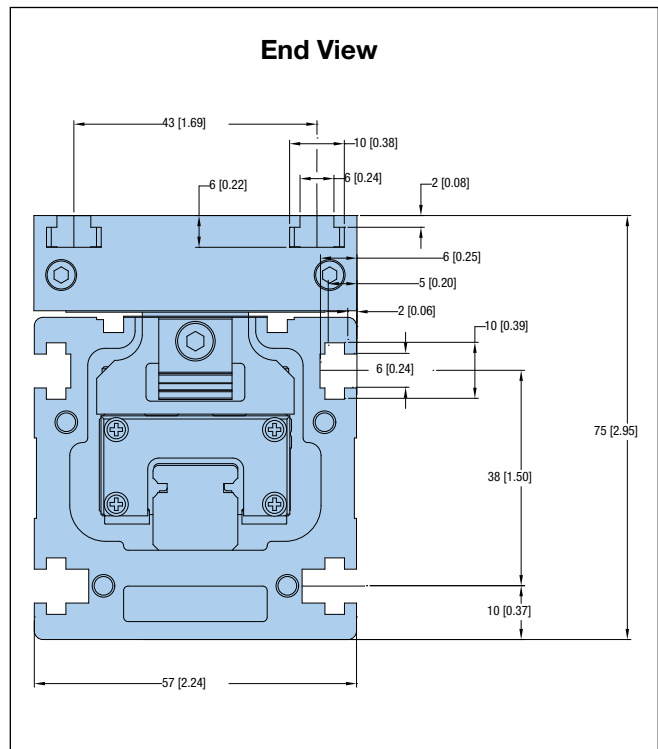
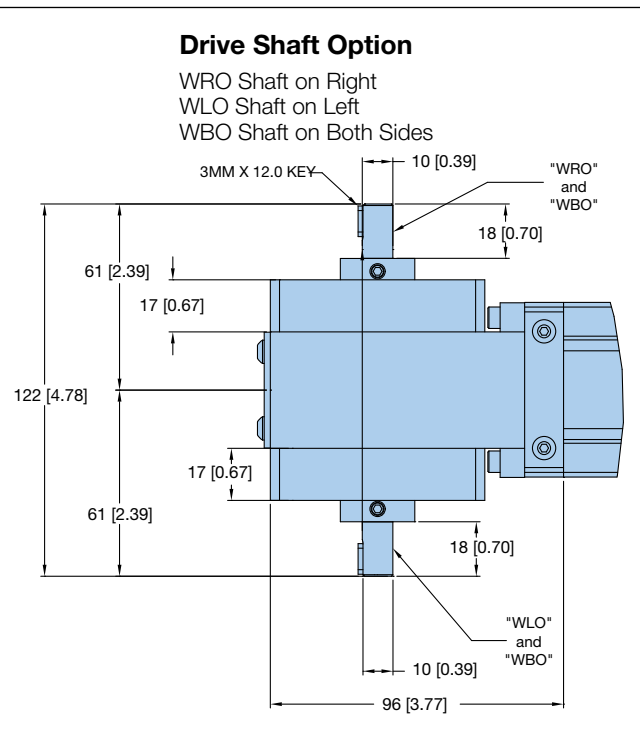
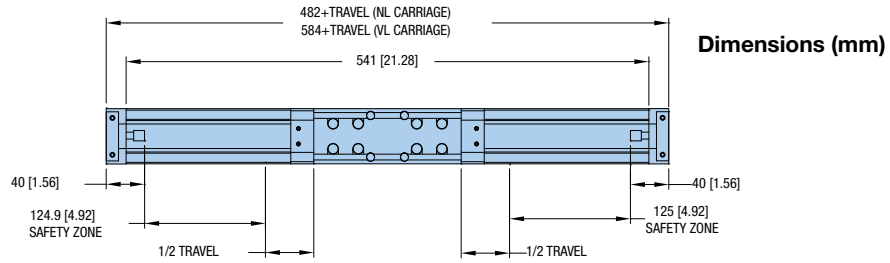

HPLA/HLE OPTIONS & ACCESSORIES

Limit and home sensors, switches, cable carriers, splice plates, and more.

See Options & Accessories at the end of the belt-driven section.

Free sizing and selection support
 from Virtual Engineer at
parker.com/VirtualEngineer



HLE100-SR Drive

Dimensions (mm)

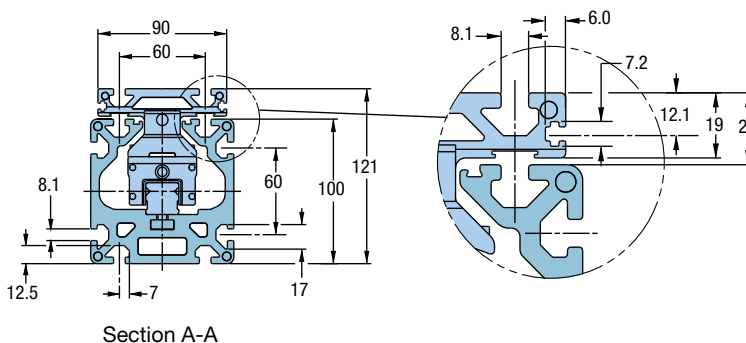
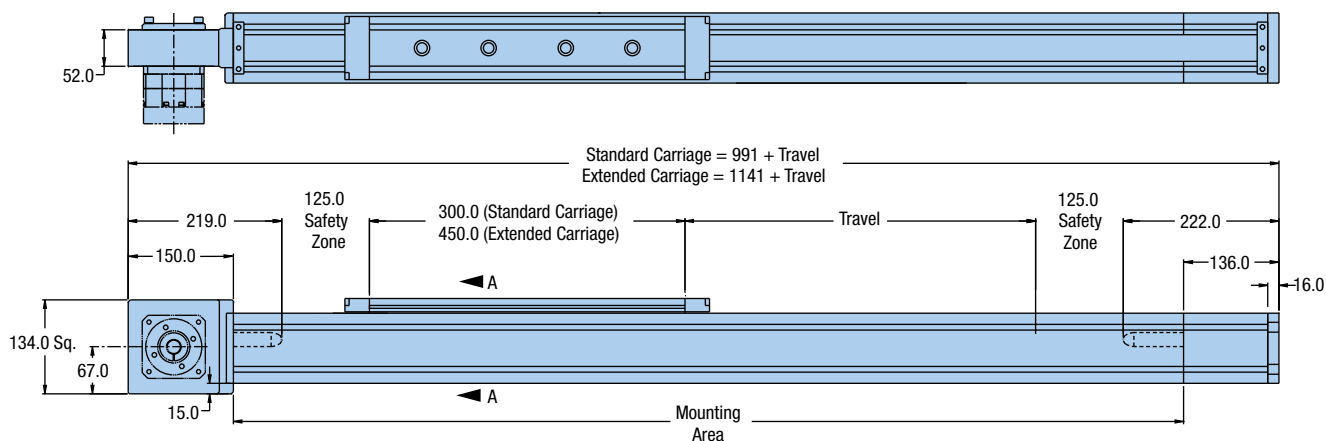

Drive Shaft Option

WRO Shaft on Right
 WLO Shaft on Left
 WBO Shaft on Both Sides

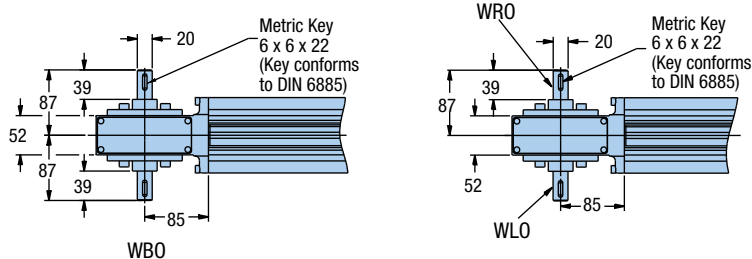

HLE100-SR Idler

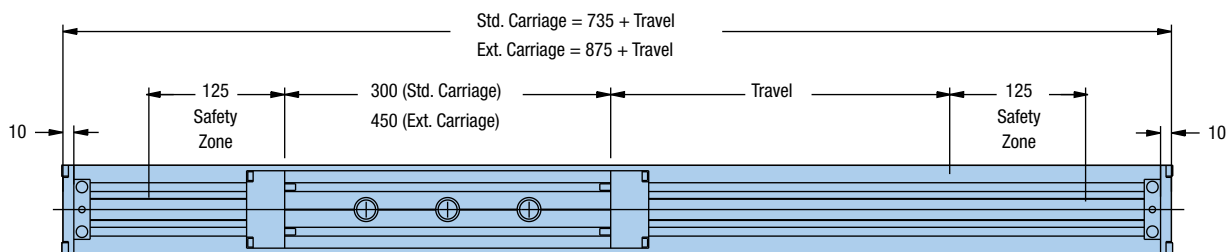

ORDERING INFORMATION HLE-SR

ORDERING INFORMATION

Fill in an order code from each of the numbered fields to create a complete model order code.

① ② ③ ④ ⑤ ⑥ ⑦ ⑧ ⑨ ⑩ ⑪ ⑫ ⑬

Order Example:

HLE060 SR NL E 2000 DA000 MBR SP5 G1205 H1 K24 ZA LH0

① **Series**
HLE060

② **Bearing Type**
SR

③ **Carriage Type**
NL Standard Carriage
VL Extended Carriage

④ **Unit Type**
M Idler
D Dual Axis Unit
E Single Axis Unit

⑤ **Travel Length**
nnnn nnnn=mm (3000 mm max for NL carriage;
2900 mm max for VL carriage)

⑥ **Drive Shaft Option - Center to Center**
DA0000 No Drive Shaft - Single Axis or Idler Unit
DAnnnn (nnnn=mm) Dual Axis Center to Center
(200 mm min; 1500 mm max)
DCnnnn (nnnn=mm) Dual Axis with Covered Link Shaft Center
to Center (200 mm min; 1500 mm max)

⑦ **Shaft Configuration Options**
WOO No Shaft, Idler Unit
ARO Gearhead Right
ALO Gearhead Left
ARW Gearhead Right Shaft Left
ALW Gearhead Left Shaft Right
WLO Shaft Left
WRO Shaft Right
WBO Double Shaft
MBL Motor Block Left
MBR Motor Block Right
MLW Motor Block Left, Shaft Right
MRW Motor Block Right, Shaft Left
DAL Double Axis Gearhead, Drive Left
DAR Double Axis Gearhead, Drive Right

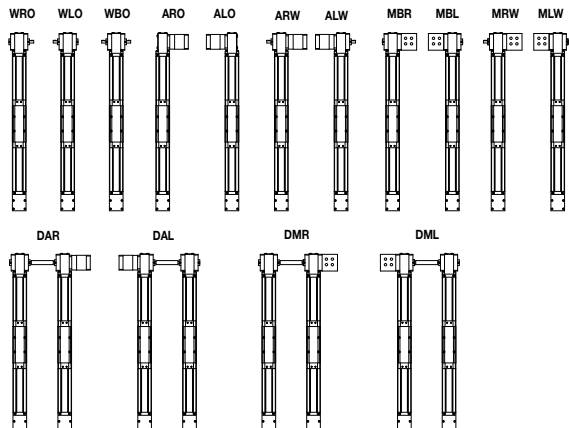

DML Double Axis, Motor Block Left
DMR Double Axis, Motor Block Right

⑧ **Drive Station Interface**

SP19 Drive Housing For PV60-FN
SP20 Idler Unit
SP21 No Motor Block
SP22 Motor Block NEMA 23 with 0.375" Bore Coupling
SP23 Motor Block NEMA 34 with 0.25" Bore Coupling
SP24 Motor Block NEMA 34 with 0.375" Bore Coupling
SP25 Motor Block NEMA 34 with 0.50" Bore Coupling
SP28 Motor Block NEMA 23 without Coupling
SP29 Motor Block NEMA 34 without Coupling
SP30 Motor Block Neo 70 with 11.0 mm Bore Coupling

⑨ **Gearbox Option***

G0 No Gearbox (Requires MBR, MBL, MRW, MLW)
G1 Customer Supplied Gearhead*
G1203 PV60 Gearhead 3:1 Ratio
G1205 PV60 Gearhead 5:1 Ratio
G1210 PV60 Gearhead 10:1 Ratio
G1215 PV60 Gearhead 15:1 Ratio
G1225 PV60 Gearhead 25:1 Ratio

*Contact factory for approval of any alternative gearbox information.

⑩ **Mounting Orientation**

H1 Carriage Up
H2 Carriage Down
H3 Carriage on Side, Drive Station Up
H4 Carriage on Side, Drive Station Down

⑪ **Motor Kit Option**

K00 No Motor Kit
K21 Motor Kit LV23, HV23, OS23, ES23, VS23 to PV60
K22 Motor Kit BE23X to PV60
K23 Motor Kit SM23, SE23 to PV60
K24 Motor Kit LV34, HV34 to PV60
K25 Motor Kit BE34, NO34X, JO34X, TS31, TS32 to PV60
K26 Motor Kit RS34, ES34 to PV60
K27 Motor Kit NO70, JO70 to PV60
K28 Motor Kit SMB60 to PV60

⑫ **Strip Seal Option**

ZA Unit with Strip Seal (IP30)
ZB Unit without Strip Seal

⑬ **Limit/Home Switch Option**

LH0 No Limit Switch Assembly
LH3 Three NPN Prox Switches, 10-30 VDC
LH4 Three PNP Prox Switches, 10-30 VDC

Belt Driven
Tables

HLE-SR

Fill in an order code from each of the numbered fields to create a complete model order code.

① ② ③ ④ ⑤ ⑥ ⑦ ⑧ ⑨ ⑩ ⑪ ⑫ ⑬

Order Example:	HLE100	SR	NL	E	2000	DA000	ARO	SP2	G2-03	H1	ZB	K2	LH0
-----------------------	---------------	-----------	-----------	----------	-------------	--------------	------------	------------	--------------	-----------	-----------	-----------	------------

- ① **Series**
HLE100
- ② **Bearing Type**
SR
- ③ **Carriage Type**
NL Standard Carriage
VL Extended Carriage
- ④ **Unit Type**
M Idler
E Timing Belt Drive, Nominal Thrust, Maximum Life
F Timing Belt Drive, Nominal Thrust, Maximum Thrust
- ⑤ **Travel Length**
nnnn Specified travel in mm (nnnn = mm)
- ⑥ **Drive Shaft Option - Center to Center**
DA0000 No Drive Shaft - Single Axis or Idler Unit
DAnnnn (nnnn=mm)
- ⑦ **Shaft Configuration Options**
WOO No Shaft, Idler Unit
WLO Shaft Left
WRO Shaft Right
WBO Double Shaft
ALO Reducer Left
ARO Reducer Right
ALW Reducer Left, Shaft Right
ARW Reducer Right, Shaft Left
DAL Double Axis, Drive Left
DAR Double Axis, Drive Right
MBL Motor Block Left
MBR Motor Block Right

- ⑧ **Drive Station Interface**
SP0 Idler or Shaft Option
SP3 Motor Block - NEMA 34 with 0.500 in. coupling
SP4 Motor Block - NEMA 34 with 0.375 in. coupling
SP5 Motor Block - NEMA 34 without coupling

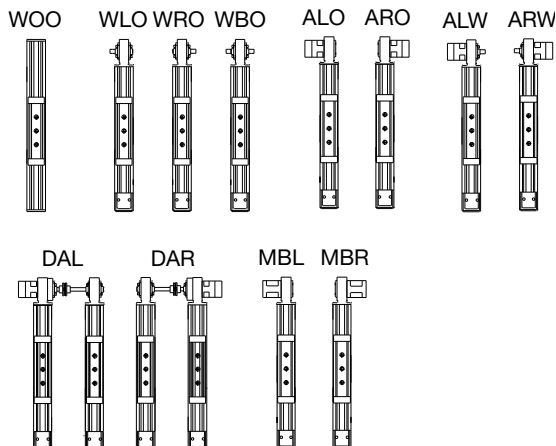

- SP6 Motor Block - with coupling for JO923 direct drive
- SP7 Motor Block - NEMA 42 with 0.625 in. coupling
- SP8 Motor Block - NEMA 42 without coupling
- SP9 Drive Housing for PX90/PV90/PEN/PER-090
- SP10 Drive Housing for PS90
- SP11 Drive Housing for PX115/PV115
- SP12 Drive Housing for PS115
- ⑨ **Gearbox Option**
G0-00 No Gearbox
G10-nn PS90
G11-nn PX115
G12-nn PS115
G13-nn PX90
G14-nn PV90
G15-nn PV115
nn = ratio Single stage ratios 3:1, 5:1, 10:1 Dual stage ratios 15:1, 25:1
- ⑩ **Mounting Orientation**
H1 Carriage Up
H2 Carriage Down
H3 Carriage on Side, Drive Station Up
H4 Carriage on Side, Drive Station Down
- ⑪ **Strip Seal Option**
ZA Unit with Strip Seal (IP30)
ZB Unit without Strip Seal
- ⑫ **Motor Kit Option**
K0 No Motor Kit
K1 J034*, N034*, BE34*, TS3*
K2 J070*, N070*
K3 J090*, N090*
K4 M105*
K5 ES3*, OEM83*, ZETA83*, S83*, RS3*
K6 J034*, N034*, BE34*, TS3*
K7 J090*, N090* to PE-115
K8 M105* to PE-115
K9 ES3*, OEM83*, ZETA83*, S83*, RS3*
K10 RS42, RE42, S106-205
K11 S106-178, S106-250
K12 M145
K35 MPP092
K37 MPP100
K39 MPP115
K41 Parker MPP142/MPJ142
K50 Parker HDY55; MPL15XX (Allen Bradley)
K51 AKM3X-AN (Kollmorgen)
K52 SGMAH-04 (Yaskawa)
K53 SGMAH-08 (Yaskawa)
K54 MKD041 (Indramat)
K55 AKM4X-AN (Kollmorgen)
K56 MKD070 (Indramat)
K57 MKD090 (INDRAMAT)
*Single stage ratios: 3, 4, 5, 8, 10; Dual stage ratios: 12, 15, 16, 20, 25
- ⑬ **Limit/Home Switch Option**
LH0 No Limit Switch Assembly
LH3 Three NPN Prox Switches, 10-30 VDC
LH4 Three PNP Prox Switches, 10-30 VDC

HZR Series

Belt-Drive Actuators for High Speed, Long Stroke Vertical Applications

- Designed as a vertical axis unit
- Load lifting capacities up to 150 kg
- Velocity up to 5 meters/sec.
- Positional repeatability of ± 0.2 mm
- Torsion-resistant housing
- Roller wheel bearings for smooth vertical motion
- High vertical acceleration

Typical Fields of Application

- Materials handling: palletization, feeding, removal
- Textile machinery building: crosscutting, slitting and stacking, quilting, seam stitching
- Process engineering: painting, coating, bonding
- Storage technology: commissioning, inventory
- Machine tool building: workpiece loading, tool changing
- Testing technology: guiding ultrasonic sensors



Belt Driven
Tables

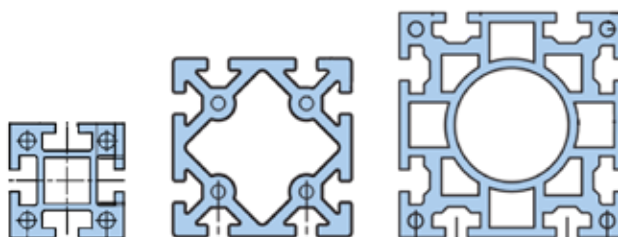

HZR050

HZR080

HZR100

	HZR50P Standard	HZR50E Extended	HZR80	HZR100
Maximum Travel (mm)	1,500	1,500	1,500	2,000
Maximum Payload (N)				
Maximum Acceleration (m/s²)	5		5	10

The HZR is a rugged vertical axis unit unique to the high speed automation industry. It is specifically designed to satisfy the mechanical demands placed on the vertical axis of a multi-axis gantry robot - utilized for high throughput lifting and transporting of heavy or bulky loads.

The payload is supported by a high strength extruded aluminum profile which is lifted and guided through a torsion-resistant cast aluminum housing. Maintenance-free, heavy duty polyamide bearing wheels evenly distribute and support the

high forces induced by rapid horizontal acceleration of the load. A wear-free, steel cord reinforced timing belt transmits large traction forces to provide high accelerations and lifting capability in the vertical direction.

SPECIFICATIONS

HZR Series

Characteristics	Units	HZR50P (Standard)		HZR50E (Extended)		HZR80		HZR100	
Unit Weight									
Basic Unit (based on 1 meter travel)	kg (lb)	15.3	(33.73)	17.2	(37.92)	37	(81.8)	60	(132.3)
Weight of additional length	kg/m (lb/ft)	2.9	(1.95)	2.9	(1.95)	7.4	(4.9)	10.2	(6.85)
Moment of Inertia (based on 1 meter travel)									
Inertia reflected to drive pulley	kg-cm ² (lb-in ²)	66.11	(22.58)	66.51	(22.72)	250	(85.4)	357	(122.0)
Travel and Speed¹									
Maximum Speed	m/s (in/s)	5	(200)	5	(200)	5	(200)	5	(200)
Maximum Acceleration	m/s ² (in/s ²)	5	(197)	5	(197)	10	(393)	10	(393)
Maximum Travel	m (in)	1.5	(59.1)	1.5	(59.1)	1.5	(59.1)	2.0	(78.7)
Geometric Data									
Cross Section (square profile)	mm (in)	50	(1.97)	50	(1.97)	80	(3.2)	100	(3.9)
Moment of Inertia I _x	cm ⁴ (in ⁴)	29.9	(0.72)	29.9	(0.72)	187.1	(4.5)	383.3	(9.2)
Section Modulus, W	cm ³ (in ³)	29.9	(1.82)	29.9	(1.82)	46.7	(2.85)	76.6	(4.67)
Pulley Data, Torques, Forces									
Travel Distance per Revolution	mm/rev (in/rev)	180	(7.09)	180	(7.09)	240	(9.45)	240	(9.45)
Pulley Diameter	mm (in)	57.3	(2.26)	57.3	(2.26)	76.4	(3.01)	76.4	(3.01)
Maximum Drive Torque	Nm (lb-in)	47	(416.3)	47	(416.3)	108	(956.7)	168	(1488.1)
Static Load	kg (lb)	45	(99.2)	45	(99.2)	75	(165)	150	(331)
Maximum Belt Traction (effective load)	N (lb)	1654	(371.8)	1654	(371.8)	2822	(635)	4410	(992)
Repeatability	mm (in)	±0.2	(±0.008)	±0.2	(±0.008)	±0.2	(±0.008)	±0.2	(±0.008)

1 For higher speeds, accelerations or longer travel consult Parker Application Engineering for assistance.



Force and Moment Loads

The forces and moments that the carriage is capable of transferring are speed-dependent. The curves shown in the graphs apply to a standard guiding (P). With the extended guiding (E), all the values apart from F_x (load-bearing capacity of timing belt) can be doubled if the load is applied equally to both halves of the carriage or distributed uniformly along its entire length.

The curves show the maximum load-bearing capacity of a carriage in one direction of force or torque. If several loads are applied in different directions, the values given by the curves must be derated, i.e. the load or speed should be reduced if necessary.

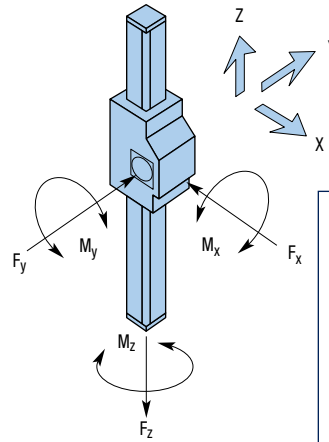

Virtual Engineer software is available for determination of precise carriage loading.

parker.com/VirtualEngineer

Belt Driven Tables

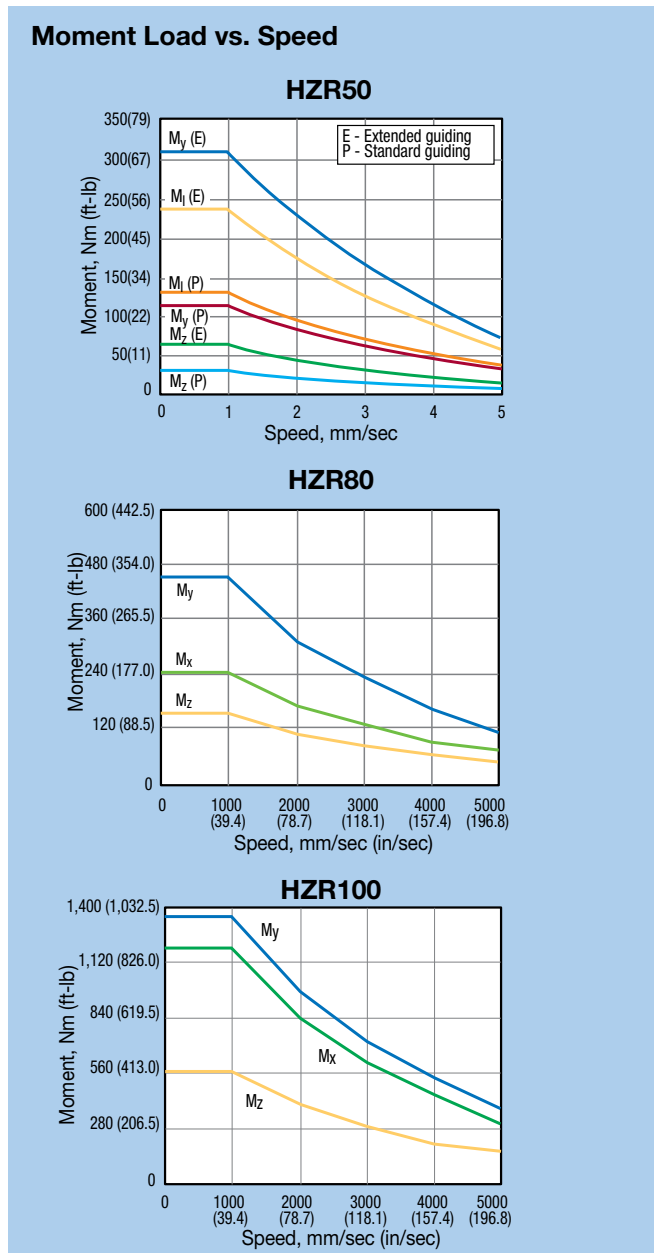
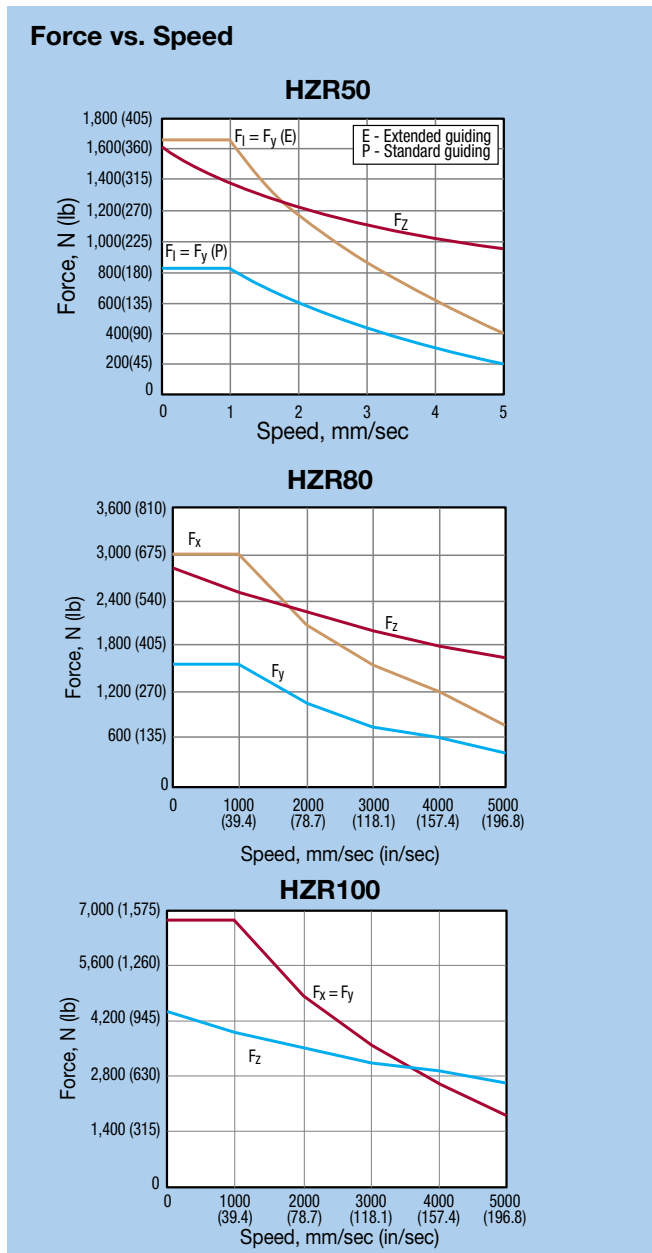

Extension Loads

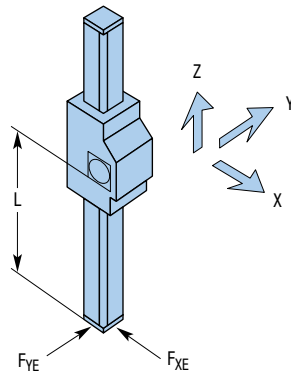

Force vs. Extended Length

HZR50

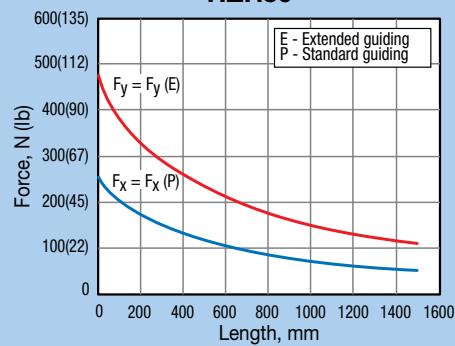

HZR80

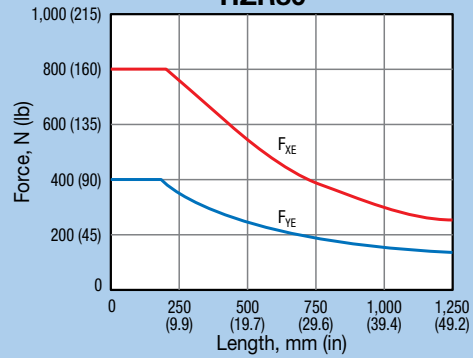

HZR100

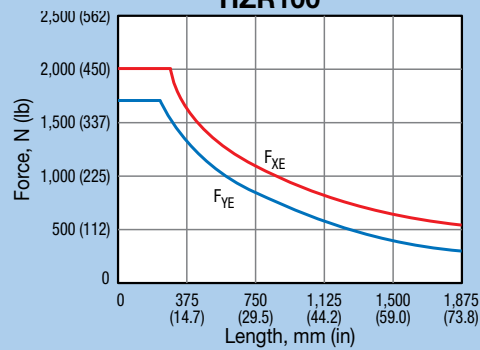

DIMENSIONS

Download 2D & 3D files from
www.parker.com/emn/HZR50



DIMENSIONS

HZR50

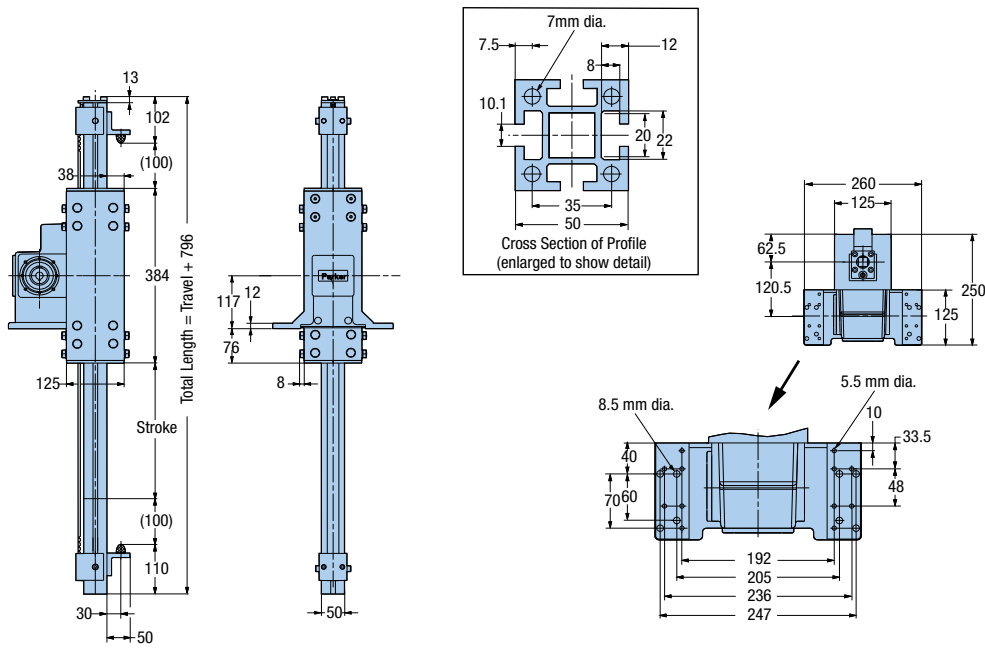

HZR80

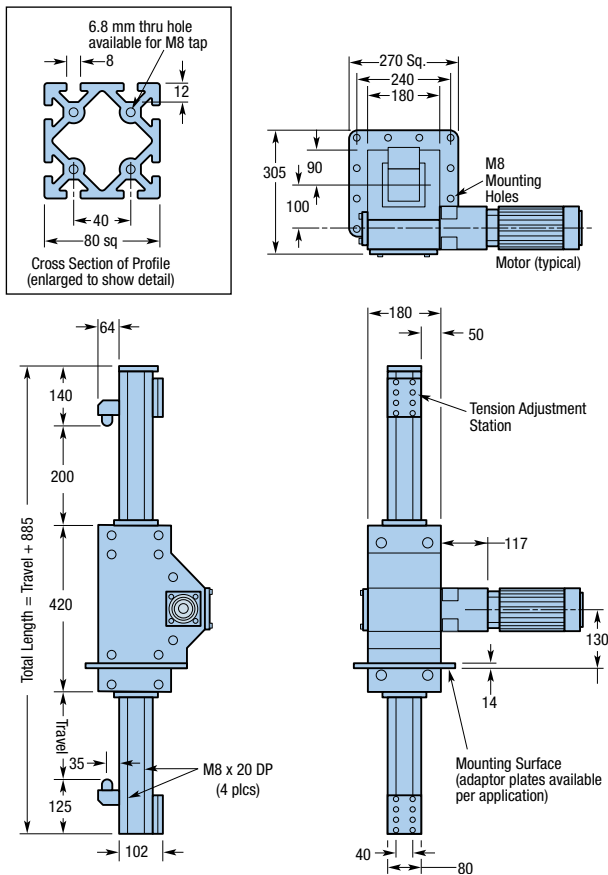

HZR100

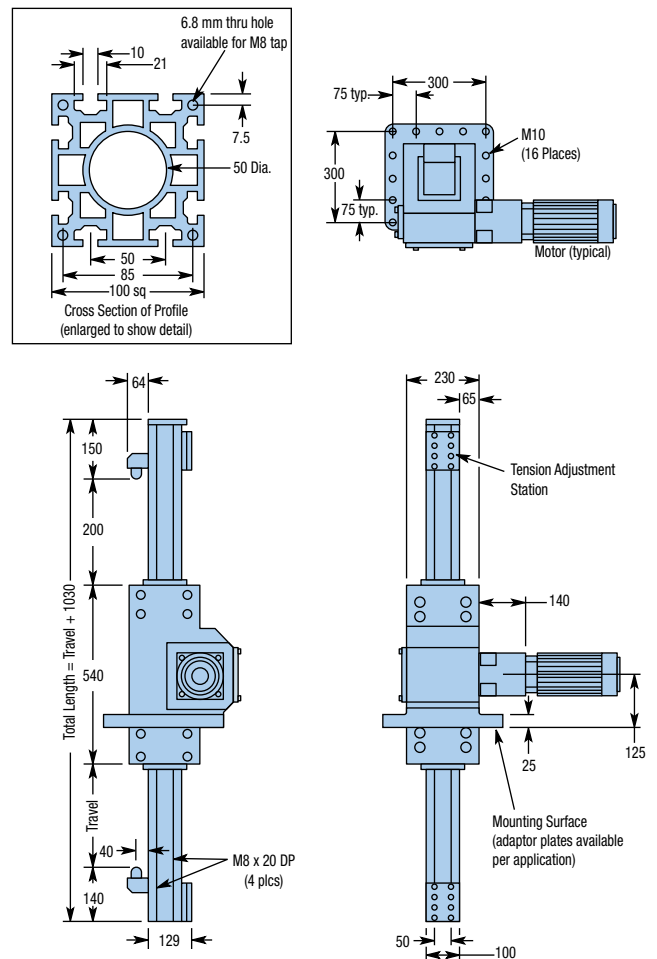

ORDERING INFORMATION

HZR Series

Fill in an order code from each of the numbered fields to create a complete model order code.

① ② ③ ④ ⑤ ⑥ ⑦ ⑧ ⑨

Order Example:

HZR80 1000 A SP2 ARO G2-03 K02 LH1 E

① **Series**

HZR50
HZR80
HZR100

② **Table Travel**

nnnn Specified travel in mm (nnnn = mm)

③ **Mounting Flange Options**

A No Mounting Flange
B HZR Mounting to HPLA80
C HZR Mounting to HLE100
D HZR Mounting to HPLA120
E HZR Mounting to HLE150

④ **Drive Station Interface**

SP10 Drive Housing for PX90/PV90
SP11 Drive Housing for PS90
SP12 Drive Housing for PX115/PV115
SP13 Drive Housing for PS115

⑤ **Orientation Options**

ARO Gearbox Right
ALO Gearbox Left

⑥ **Gearbox Option**

G0-00 No Gearbox
G1-nn Customer Supplied
G08-nn PX90 Gearbox included
G09-nn PX115 Gearbox included
G10-nn PS90 Gearbox included
G11-nn PS115 Gearbox included
G12-nn PS142 Gearbox included

nn = ratio

Single stage ratios 3:1, 5:1, 10:1 Dual stage ratios 15:1, 25:1

⑦ **Motor Kit Option**

K00 No Motor Kit
K20 Parker ES23X
K21 Parker BE23X
K23 Parker N070, Allen Bradley MPL15XX
K24 Parker N092
K26 Parker LV/HV34
K34 Parker MPP092/MPJ092
K36 Parker MPP100/MPJ100
K39 Parker MPP115/MPJ115
K41 Parker MPP142/MPJ142
K50 Parker HDY55; MPL15XX (Allen Bradley)
K51 AKM3X-AN (Kollmorgen)
K52 SGMAH-04 (Yaskawa)
K53 SGMAH-08 (Yaskawa)
K54 MKD041 (Indramat)
K55 AKM4X-AN (Kollmorgen)
K56 MKD070 (Indramat)

⑧ **Limit Switch Assembly**

LH0 No Switch Assembly
LH1 Three mechanical switches, with 1 NO and 1 NC contact per switch (HZR80 and HZR100)
LH2 Two mechanical switches and 1 NPN proximity switch (HZR80 and HZR100)
LH3 Three NPN proximity switches NO/NC, 10-30 VDC (HZR80 and HZR100)
LH4 Three PNP proximity switches NO/NC, 10-30 VDC (HZR80 and HZR100)
LH5 Three NPN proximity switches NO "Home"; NC Travel Limits 10-30 VDC (HZR50 only)
LH6 Three NPN proximity switches NO "Home"; NC Travel Limits 10-30 VDC (HZR50 only)

⑨ **Extended Option**

E 16 Additional Rollers (HZR50 only)

Free sizing and selection support
from Virtual Engineer at
parker.com/VirtualEngineer



Parker Gantry Robot Systems

Minimize Your Engineering Effort

Parker's gantry systems provide cost-effective, easy to integrate solutions that satisfy the vast majority of automation requirements. In addition to our standard gantry systems, Parker offers products with additional capabilities to fulfill the needs of special applications. Our engineering skill and manufacturing expertise have integrated these products into custom-tailored gantry solutions which have successfully addressed the most unique and exacting requirements of machine builders and integrators around the world.

Additional Capabilities

- Motors, Drives and Controls
- Extended Travels
- Rotary Motion Modules
- Cleanroom Preparations
- External Position Feedback
- Vertical Axis Brakes
- End Effectors
- Protective Guarding
- Custom Support Structures

Belt Driven
Tables

Gantry Robot Elements

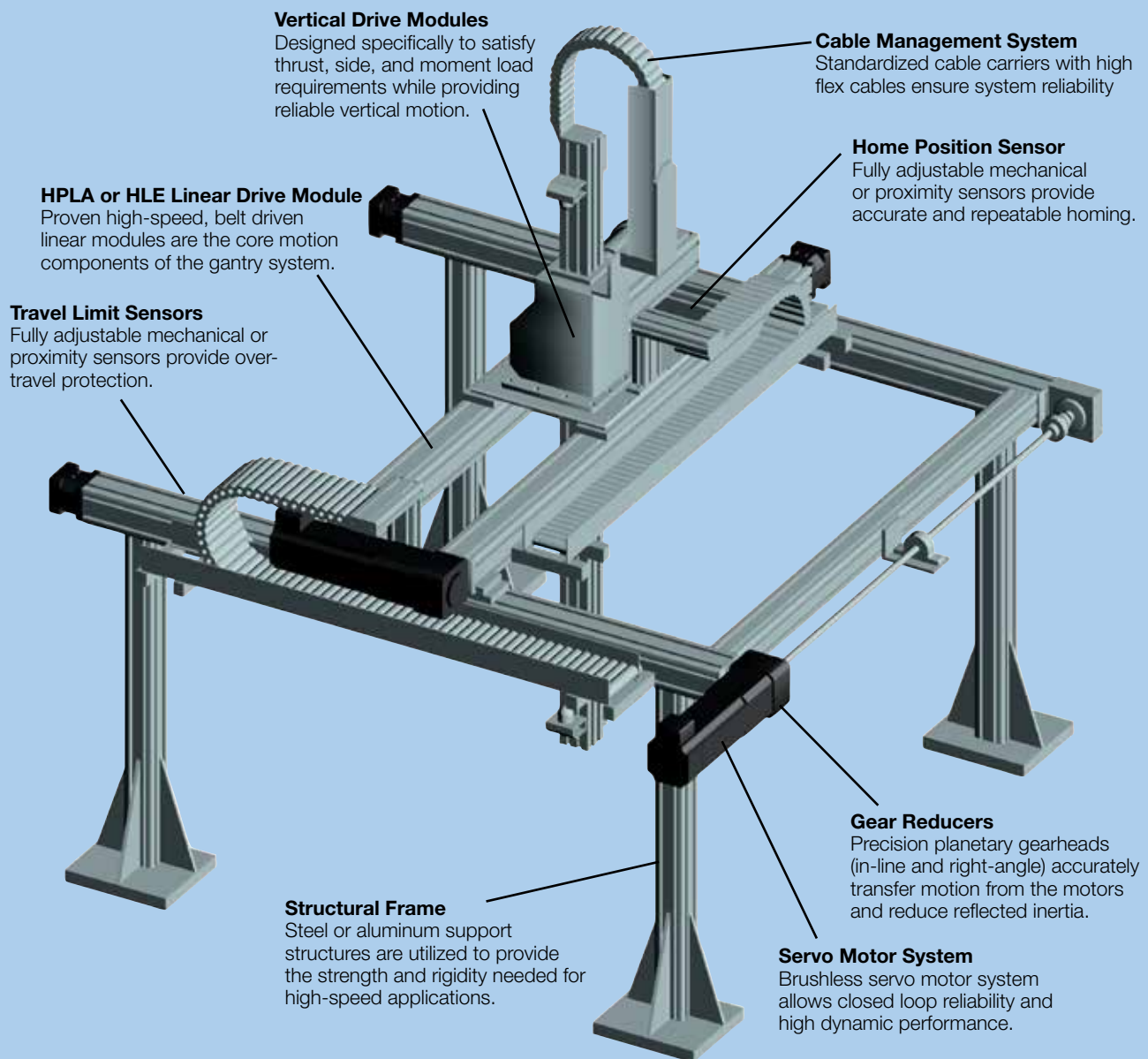

Seven Standard Configurations

Parker's seven standard system configurations are designed to satisfy the vast majority of gantry robot applications. By standardizing on these configurations, Parker has simplified sizing and selection, shortened lead times, and reduced costs for users of these systems. The travels and loads indicated are nominal, and should not be considered limiting factors. Longer travels and increased loads are attainable depending upon the combination of parameters.

System One
Two Axis: XX' - Y



System Four
Two Axis: XX' - Z

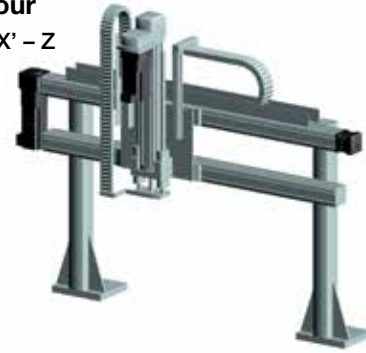

System Five
Two Axis: XX' - Z



System Two
Two Axis: XX' - YY'



System Six
Three Axis: XX' - YY' - Z

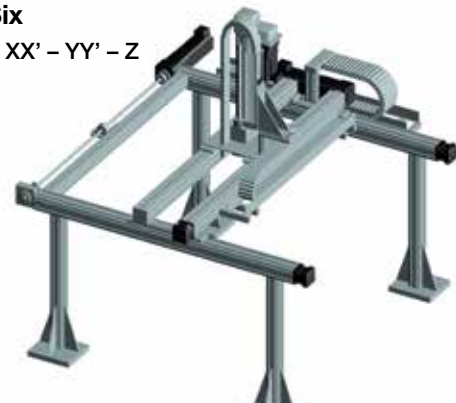

System Three
Two Axis: XX' - Z



System Seven
Three Axis: XX' - YY' - Z

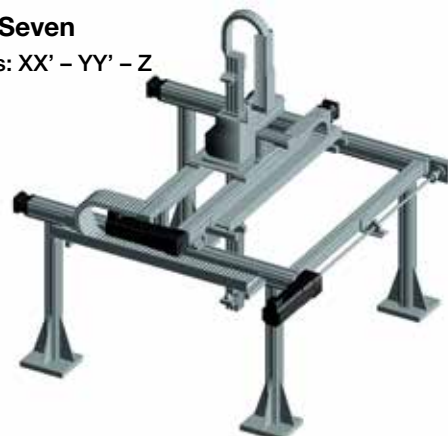

System One

System One provides two axes of horizontal motion. The primary axis (X) is comprised of two HPLA or HLE Linear Modules linked by a common drive shaft, and the secondary axis (Y) is comprised of one HPLA or HLE Linear Module. These linear modules are capable of high speeds and accelerations over long travels. This system is designed for rapid transport of light to moderate loads in a single horizontal plane.

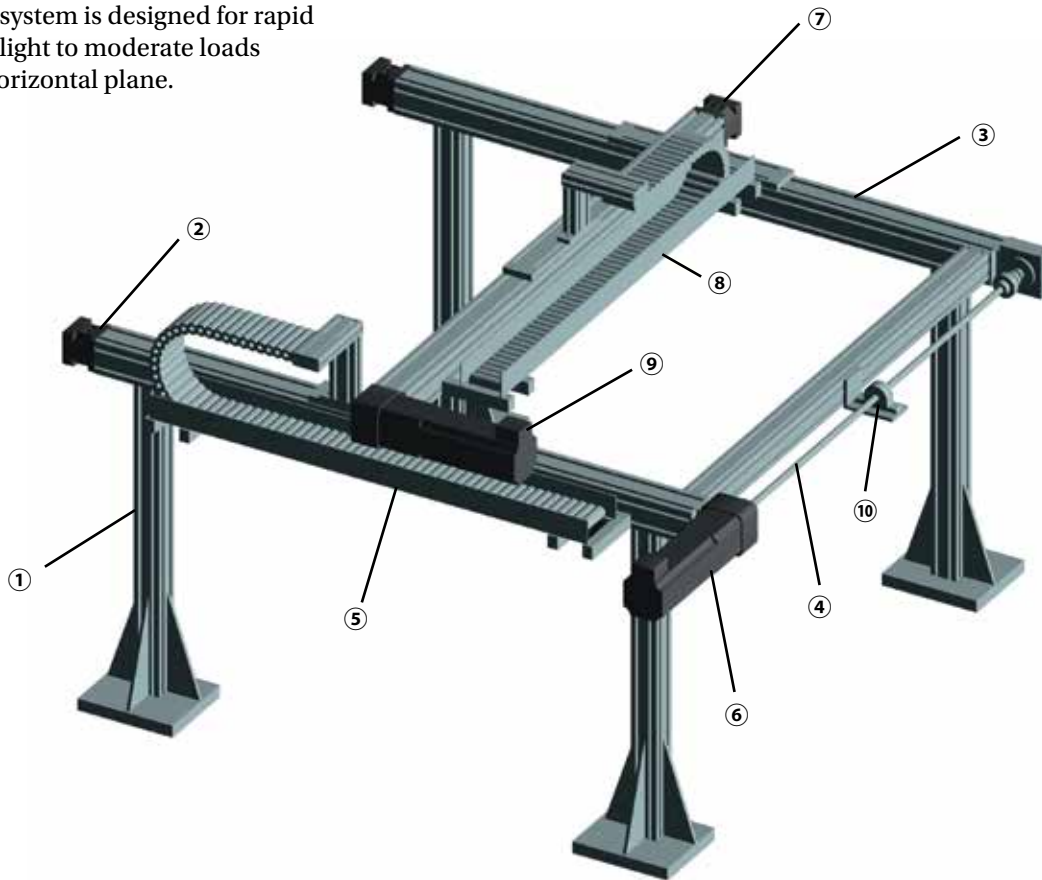
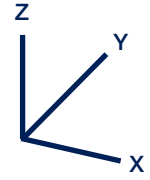

Belt Driven Tables

- ① Support Structure Available (steel or aluminum framing)
- ② X-Axis Drive Rail Assembly
- ③ X-Axis Driven Rail Assembly
- ④ X-Axis Link Shaft Assembly
- ⑤ X-Axis Cable Carrier
- ⑥ X-Axis Drive Motor
- ⑦ Y-Axis Drive Rail Assembly
- ⑧ Y-Axis Cable Carrier
- ⑨ Y-Axis Drive Motor
- ⑩ Pillow Block Bearing & Support (Based on Application)

Series No.	Axis Model Number			Load (kg)	Travel			Velocity		
	X-Axis	Y-Axis	Z-Axis		X-Axis (meters)	Y-Axis (meters)	Z-Axis (meters)	X-Axis (m/sec.)	Y-Axis (m/sec.)	Z-Axis (m/sec.)
1	HLE60RB	HLE60RB	—	15	2.9	1.3	—	2.0	2.0	—
2	HLE60SR	HLE60SR	—	25	2.8	1.3	—	2.0	2.0	—
3	HPLA080	HPLA080	—	30	5.4	2.0	—	2.0	3.0	—
4	HLE100RB	HLE100RB	—	35	6.0	2.0	—	2.0	3.0	—
5	HLE100SR	HLE100SR	—	75	6.0	2.0	—	2.0	3.0	—
6	HPLA120	HPLA120	—	85	9.3	3.0	—	2.0	3.0	—
7	HLE150RB	HLE150RB	—	100	7.9	3.0	—	2.0	3.0	—

Note: Loads, travels, and velocities shown are interdependent. Increased values are attainable. Actual configuration will depend on application requirements. Please consult factory for more details.

System Two

System Two utilizes two linear modules in both axes (X & Y). The second linear module of the Y-axis is an idler unit which increases load capacity (normal and moment) and permits longer travel. The addition of this unit doubles the load capacity over System One. Traction force can be improved by linking the second axis (Y) module to the first with a common drive shaft. The link shaft doubles the potential acceleration of the system. This system is intended for moderate to heavy loads.

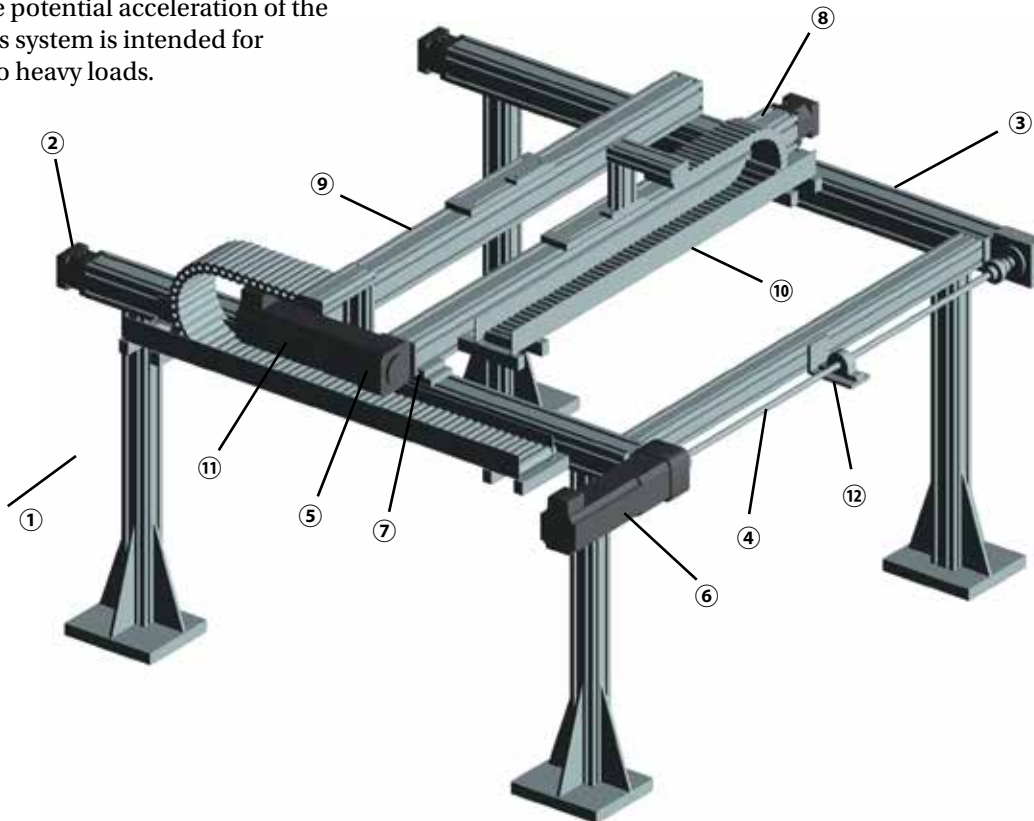
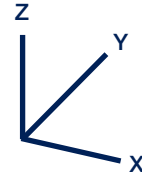

- ① Support Structure Available (steel or aluminum framing)
- ② X-Axis Drive Rail Assembly
- ③ X-Axis Driven Rail Assembly
- ④ X-Axis Link Shaft Assembly
- ⑤ X-Axis Cable Carrier
- ⑥ X-Axis Drive Motor
- ⑦ Clamping Profile
- ⑧ Y-Axis Drive Rail Assembly
- ⑨ Y-Axis Idler Rail Assembly
- ⑩ Y-Axis Cable Carrier
- ⑪ Y-Axis Drive Motor
- ⑫ Pillow Block Bearing & Support (Based on Application)

Series No.	Axis Model Number			Load (kg)	Travel (meters)			Velocity (m/sec.)		
	X-Axis	Y-Axis	Z-Axis		X-Axis	Y-Axis	Z-Axis	X-Axis	Y-Axis	Z-Axis
1	HLE60RB	HLE60RB	—	30	2.9	1.3	—	1.0	2.0	—
2	HLE60SR	HLE60SR	—	50	2.8	1.3	—	1.0	2.0	—
3	HPLA080	HPLA080	—	60	5.4	2.0	—	2.0	3.0	—
4	HLE100RB	HLE100RB	—	70	6.0	2.0	—	1.5	4.0	—
5	HLE100SR	HLE100SR	—	150	6.0	2.0	—	1.5	4.0	—
6	HPLA120	HPLA120	—	170	9.3	3.0	—	2.0	4.0	—
7	HLE150RB	HLE150RB	—	200	7.9	3.0	—	2.0	4.0	—

Note: Loads, travels, and velocities shown are interdependent. Increased values are attainable. Actual configuration will depend on application requirements. Please consult factory for more details.

System Three

System Three provides two axes of motion in a vertical plane. A ballscrew driven ET Cylinder is utilized to provide high thrust in the vertical direction. ET Rod Guides, in conjunction with the dual X-axis, minimize the effects of moment and side loading, permitting higher acceleration of the payload.

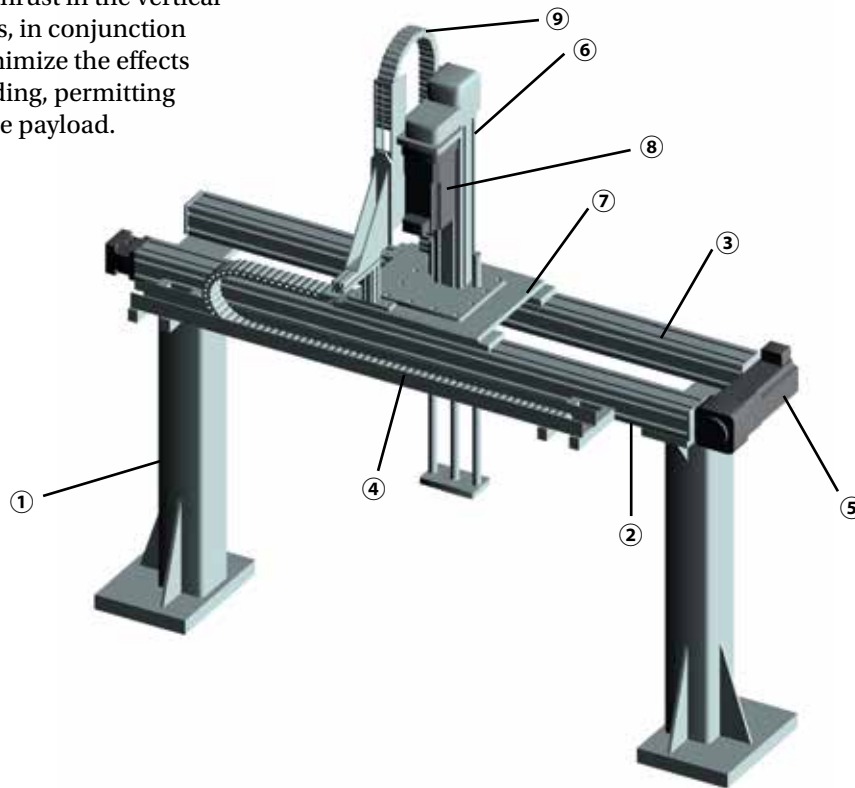
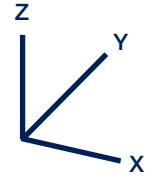

- ① Support Structure Available (steel or aluminum framing)
- ② X-Axis Drive Rail Assembly
- ③ X-Axis Idler Rail Assembly
- ④ X-Axis Cable Carrier
- ⑤ X-Axis Drive Motor
- ⑥ ET Cylinder Z-Axis with Flange Plate
- ⑦ Z-Axis Mounting Plate
- ⑧ Z-Axis Drive Motor
- ⑨ Z-Axis Cable Carrier

Series No.	Axis Model Number			Load (kg)	Travel			Velocity		
	X-Axis	Y-Axis	Z-Axis		X-Axis (meters)	Y-Axis (meters)	Z-Axis (meters)	X-Axis (m/sec.)	Y-Axis (m/sec.)	Z-Axis (m/sec.)
1	HLE60RB	—	ETB32	10	2.9	—	0.3	1.5	—	0.5
2	HLE60RB	—	ETB50	20	2.9	—	0.5	1.5	—	0.8
3	HLE60SR	—	ETB32	10	2.8	—	0.3	1.5	—	0.5
4	HLE60SR	—	ETB50	20	2.8	—	0.5	1.5	—	0.8
5	HPLA080	—	ETB50	35	5.4	—	0.5	2.0	—	0.8
6	HLE100RB	—	ETB50	40	6.0	—	0.5	2.0	—	0.8
7	HLE100RB	—	ETB80	50	6.0	—	1.0	2.0	—	0.5
8	HLE100SR	—	ETB50	40	6.0	—	0.5	2.0	—	0.5
9	HLE100SR	—	ETB80	50	6.0	—	1.0	2.0	—	0.5
10	HPLA120	—	ETB80	75	9.3	—	1.0	2.5	—	0.5
11	HPLA120	—	ETB100	100	9.3	—	1.0	2.5	—	1.0
12	HLE150RB	—	ETB80	75	7.9	—	1.0	2.5	—	0.5
13	HLE150RB	—	ETB100	100	7.9	—	1.0	2.5	—	1.0

Note: Loads, travels, and velocities shown are interdependent. Increased values are attainable. Actual configuration will depend on application requirements. Please consult factory for more details.

System Four

System Four is a variation of System Three that offers an alternative mounting arrangement. It is a popular choice for front loading applications and is often implemented as a wall mount unit.

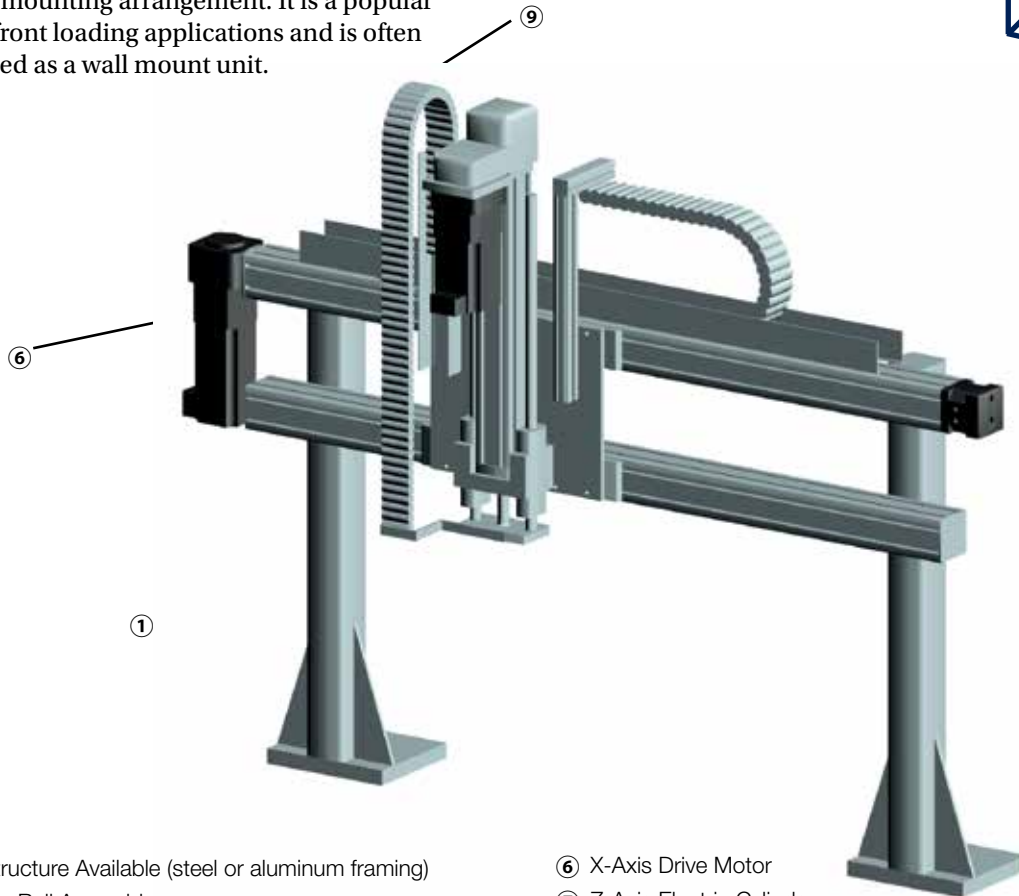
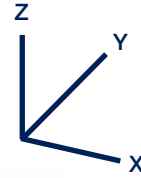

- ① Support Structure Available (steel or aluminum framing)
- ② X-Axis Drive Rail Assembly
- ③ X-Axis Idler Rail Assembly
- ④ Z-Axis Mounting Plate
- ⑤ X-Axis Cable Carrier
- ⑥ X-Axis Drive Motor
- ⑦ Z-Axis Electric Cylinder
- ⑧ Z-Axis Drive Motor
- ⑨ Z-Axis Cable Carrier

Series No.	Axis Model Number			Load (kg)	Travel (meters)			Velocity (m/sec.)		
	X-Axis	Y-Axis	Z-Axis		X-Axis	Y-Axis	Z-Axis	X-Axis	Y-Axis	Z-Axis
1	HLE60RB	—	ETB32	10	2.9	—	0.3	1.5	—	0.5
2	HLE60RB	—	ETB50	20	2.9	—	0.5	1.5	—	0.8
3	HLE60SR	—	ETB32	10	2.8	—	0.3	1.5	—	0.5
4	HLE60SR	—	ETB50	20	2.8	—	0.5	1.5	—	0.8
5	HPLA080	—	ETB50	35	5.4	—	0.5	2.0	—	0.8
6	HLE100RB	—	ETB50	40	6.0	—	0.5	2.0	—	0.8
7	HLE100RB	—	ETB80	50	6.0	—	1.0	2.0	—	0.5
8	HLE100SR	—	ETB50	40	6.0	—	0.5	2.0	—	0.5
9	HLE100SR	—	ETB80	50	6.0	—	1.0	2.0	—	0.5
10	HPLA120	—	ETB80	75	9.3	—	1.0	2.5	—	0.5
11	HPLA120	—	ETB100	100	9.3	—	1.0	2.5	—	1.0
12	HLE150RB	—	ETB80	75	7.9	—	1.0	2.5	—	0.5
13	HLE150RB	—	ETB100	100	7.9	—	1.0	2.5	—	1.0

Note: Loads, travels, and velocities shown are interdependent. Increased values are attainable. Actual configuration will depend on application requirements. Please consult factory for more details.

System Five

System Five is an X-Z system utilizing the HZR belt driven unit for the vertical axis. The rigidity of the HZR permits higher vertical speed, greater X-axis acceleration, and larger moment loading than System Three.

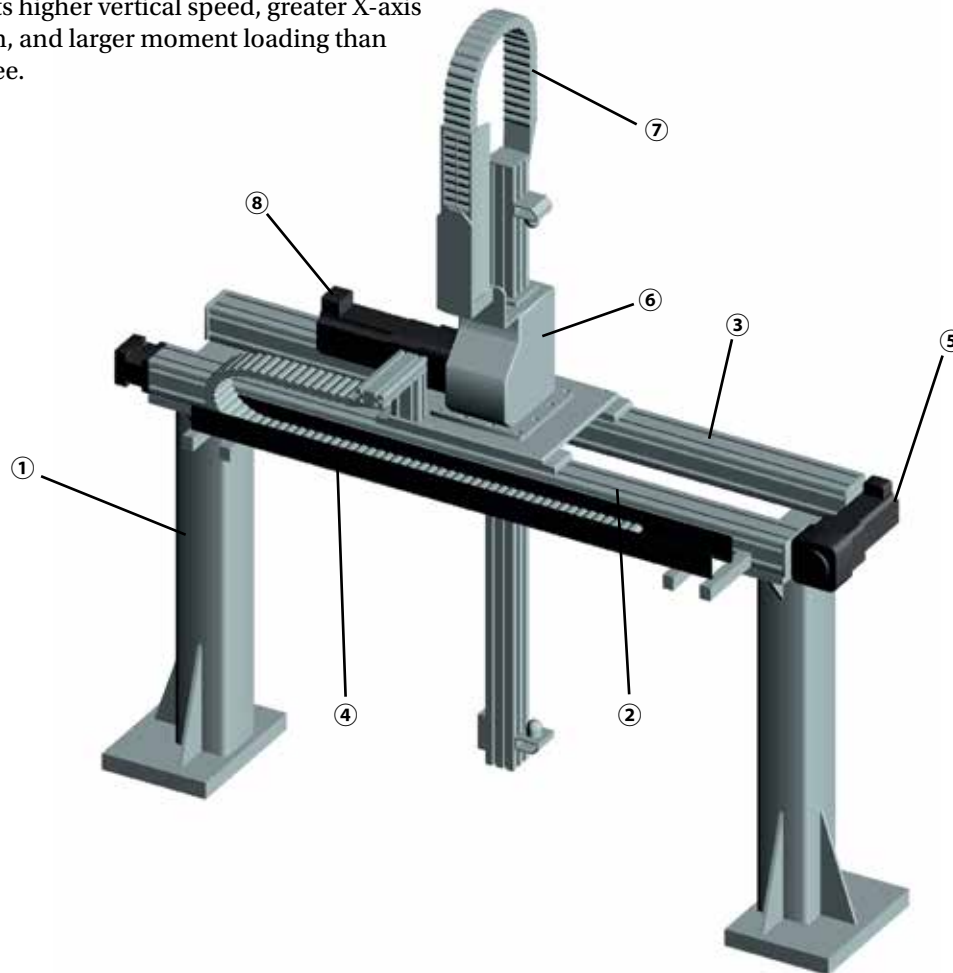
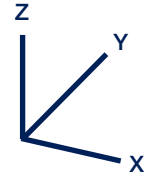

Belt Driven Tables

- ① Support Structure Available (steel or aluminum framing)
- ② X-Axis Drive Rail Assembly
- ③ X-Axis Idler Rail Assembly
- ④ X-Axis Cable Carrier
- ⑤ X-Axis Drive Motor
- ⑥ HZR Z-Axis with Flange Plate
- ⑦ Z-Axis Cable Carrier
- ⑧ Z-Axis Drive Motor

Series No.	Axis Model Number			Load (kg)	Travel (meters)			Velocity (m/sec.)		
	X-Axis	Y-Axis	Z-Axis		X-Axis	Y-Axis	Z-Axis	X-Axis	Y-Axis	Z-Axis
1	HLE100RB	—	HZR80	50	6.0	—	1.0	2.0	—	1.5
2	HLE100RB	—	HZR100	100	6.0	—	1.5	2.0	—	1.5
3	HLE100SR	—	HZR80	50	6.0	—	1.0	2.0	—	1.5
4	HLE100SR	—	HZR100	100	6.0	—	1.5	2.0	—	1.5
5	HPLA120	—	HZR80	50	9.3	—	1.0	2.5	—	1.5
6	HPLA120	—	HZR100	100	9.3	—	1.5	2.5	—	1.5
7	HLE150RB	—	HZR80	50	7.9	—	1.0	2.5	—	1.5
8	HLE150RB	—	HZR100	100	7.9	—	1.5	2.5	—	1.5

Note: Loads, travels, and velocities shown are interdependent. Increased values are attainable. Actual configuration will depend on application requirements. Please consult factory for more details.

System Six

System Six is a three-axes version of System Two. HPLA/ HLE linear modules provide motion in the X and Y directions while a vertically mounted ET cylinder provides the third axis (Z) of motion. The ET cylinder provides high vertical thrust capacity at moderate speeds. With the Z-axis retracted, this system can transport moderate to heavy loads at high rates of speed over long travel distances.

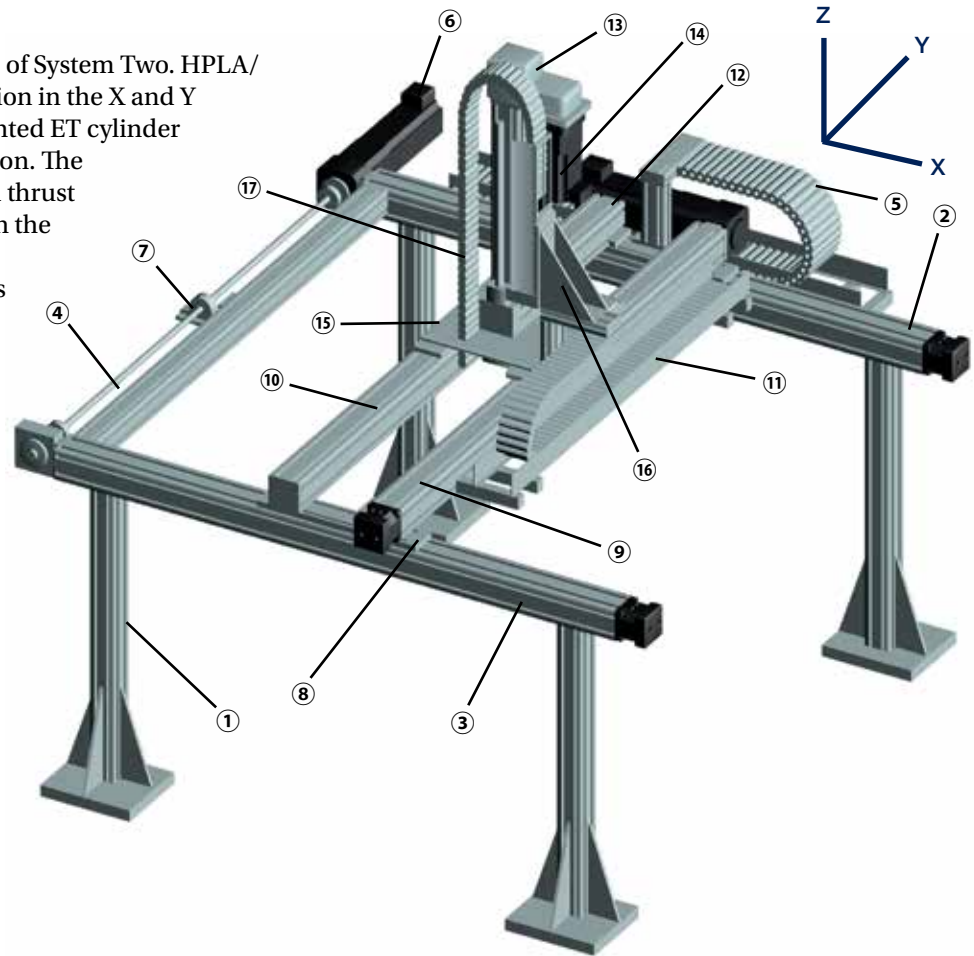

- ① Support Structure Available (steel or aluminum framing)
- ② X-Axis Drive Rail Assembly
- ③ X-Axis Driven Rail Assembly
- ④ X-Axis Link Shaft Assembly
- ⑤ X-Axis Cable Carrier
- ⑥ X-Axis Drive Motor
- ⑦ Pillow Block Bearing Support (Based on Application)
- ⑧ Clamping Profile
- ⑨ Y-Axis Drive Rail Assembly
- ⑩ Y-Axis Idler Rail Assembly
- ⑪ Y-Axis Cable Carrier
- ⑫ Y-Axis Drive Motor
- ⑬ Z-Axis ET Electric Cylinder
- ⑭ Z-Axis Drive Motor
- ⑮ Electric Cylinder Mounting Plate
- ⑯ Electric Cylinder Mounting Bracket
- ⑰ Z-Axis Cable Carrier

Series No.	Axis Model Number			Load (kg)	Travel (meters)			Velocity (m/sec.)		
	X-Axis	Y-Axis	Z-Axis		X-Axis	Y-Axis	Z-Axis	X-Axis	Y-Axis	Z-Axis
1	HLE60RB	HLE60RB	ETB32	10	2.9	1.0	0.3	1.0	1.5	0.5
2	HLE60RB	HLE60RB	ETB50	20	2.9	0.5	0.5	1.0	1.5	0.8
3	HLE60SR	HLE60SR	ETB32	10	2.8	1.0	0.3	1.0	1.5	0.5
4	HLE60SR	HLE60SR	ETB50	20	2.8	0.5	0.5	1.0	1.5	0.8
5	HPLA080	HPLA080	ETB50	45	5.4	1.5	0.5	2.0	2.0	0.8
6	HLE100RB	HLE100RB	ETB80	50	6.0	1.5	1.0	2.0	2.0	0.5
7	HLE100SR	HLE100SR	ETB80	50	6.0	1.4	1.0	2.0	2.0	0.5
8	HPLA120	HPLA120	ETB100	100	9.3	3.0	1.0	2.5	2.5	1.0
9	HLE150RB	HLE150RB	ETB100	100	7.9	3.0	1.0	2.5	2.5	1.0

Note: Loads, travels, and velocities shown are interdependent. Increased values are attainable. Actual configuration will depend on application requirements. Please consult factory for more details.

System Seven

System Seven is a three-axes system which utilizes the HZR unit for the vertical axis. As a result, this system can provide longer vertical travel, higher speed, and greater acceleration than System Six. The inherent rigidity of the HZR also contributes to superior system stiffness, stability, and ease of tuning. If the Z-axis is retracted during horizontal motion, System Seven can easily handle moderate to heavy loads. With the Z-axis fully extended it can handle light to moderate loads.

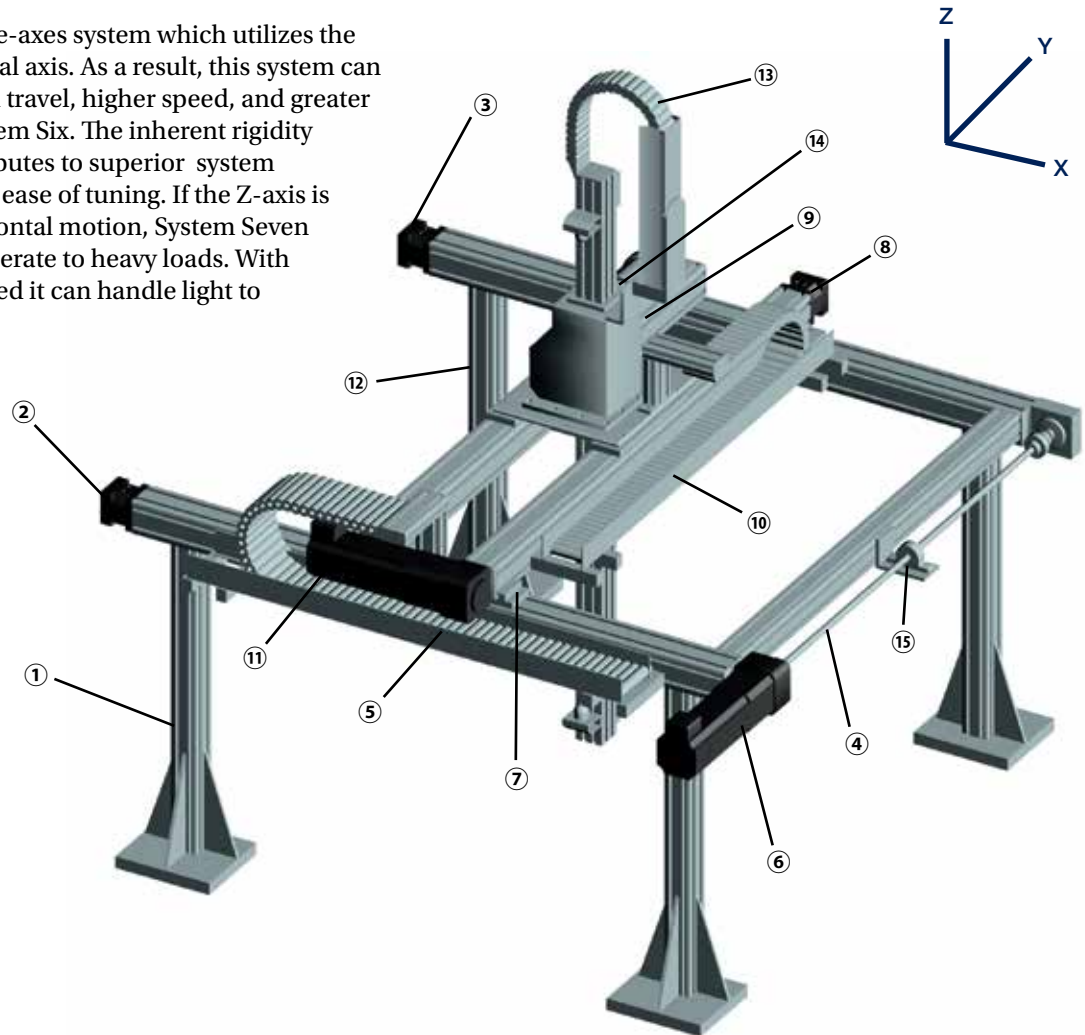

Belt Driven Tables

- | | |
|--|---|
| <ul style="list-style-type: none"> ① Support Structure Available (steel or aluminum framing) ② X-Axis Drive Rail Assembly ③ X-Axis Driven Rail Assembly ④ X-Axis Link Shaft Assembly ⑤ X-Axis Cable Carrier ⑥ X-Axis Drive Motor ⑦ Clamping Profile ⑧ Y-Axis Drive Rail Assembly | <ul style="list-style-type: none"> ⑨ Y-Axis Idler Rail Assembly ⑩ Y-Axis Cable Carrier ⑪ Y-Axis Drive Motor ⑫ HZR Z-Axis with Flange Plate ⑬ Z-Axis Cable Carrier ⑭ Z-Axis Drive Motor ⑮ Pillow Block Bearing & Support (Based on Application) |
|--|---|

Series No.	Axis Model Number			Load (kg)	Travel (meters)			Velocity (m/sec.)		
	X-Axis	Y-Axis	Z-Axis		X-Axis	Y-Axis	Z-Axis	X-Axis	Y-Axis	Z-Axis
1	HLE100RB	HLE100RB	HZR80	50	6.0	2.0	1.0	2.0	2.0	1.5
2	HLE100RB	HLE100RB	HZR100	100	6.0	1.3	1.5	2.0	2.0	1.5
3	HLE100SR	HLE100SR	HZR80	50	6.0	2.0	1.0	2.0	2.0	1.5
4	HLE100SR	HLE100SR	HZR100	100	6.0	1.3	1.5	2.0	2.0	1.5
5	HPLA120	HPLA120	HZR80	50	9.3	4.0	1.0	2.5	2.5	1.5
6	HPLA120	HPLA120	HZR100	100	9.3	3.3	1.5	2.5	2.5	1.5
7	HLE150RB	HLE150RB	HZR80	50	7.9	4.0	1.0	2.5	2.5	1.5
8	HLE150RB	HLE150RB	HZR100	100	7.9	3.3	1.5	2.5	2.5	1.5

Note: Loads, travels, and velocities shown are interdependent. Increased values are attainable. Actual configuration will depend on application requirements. Please consult factory for more details.

Gantry Systems Capabilities & Accessories

Parker's gantry systems provide cost-effective, easy to integrate solutions that satisfy the vast majority of automation requirements. In addition to these standard gantry systems, Parker offers products with additional capabilities to fulfill the needs of special applications. Our engineering skill and manufacturing expertise have integrated these products into custom-tailored gantry solutions which have successfully addressed the most unique and exacting requirements of machine builders and integrators around the world.

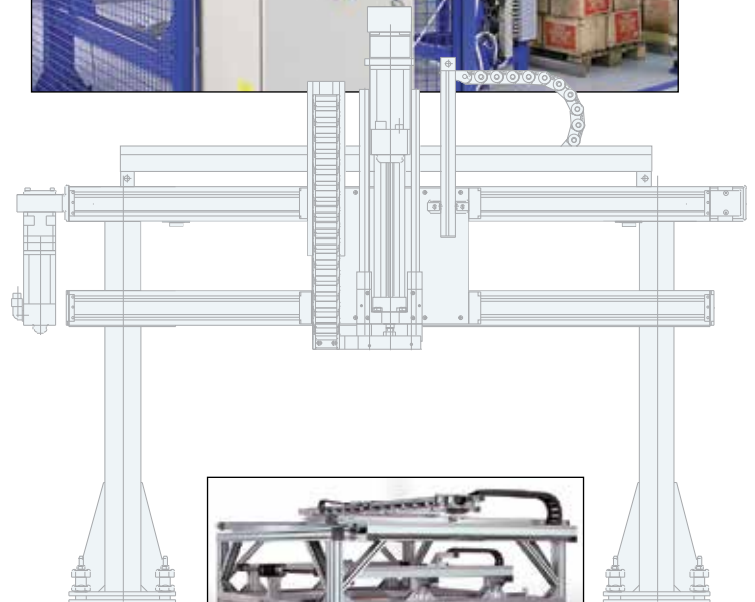

Support Structures

Parker can include the support structure and machine guarding as part of your complete system solution. Parker's ParFrame™ extruded aluminum structures are suited for light to medium duty requirements. High strength steel supports are offered for applications involving greater loads and forces.

Aluminum Structures

- Lightweight aluminum extrusions
- Economical modular construction
- Standard metric sizes – compatible with linear drive units

Steel Support Structures

- Heavy duty support
- High system stiffness
- Ideal for higher overhead gantries
- Engineered and fabricated to customer specifications



HPLA/HLE/HZR OPTIONS & ACCESSORIES

Limit and Home Sensors

“End of Travel” Limit Sensors are offered to assure safe operation of the unit by restricting travel to within allowable parameters. This range is dependent upon the load, velocity and acceleration factors determined by the application.

A “Home” Sensor can be positioned to establish a “Machine Start-up” location within the range of travel. Either mechanical or electrical proximity switches can be selected. Limit sensors can be easily positioned along the length of travel to further reduce the allowable operating envelope.

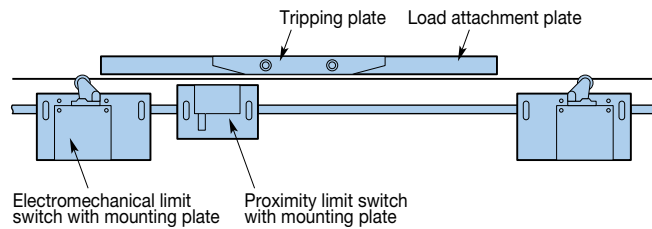

Electrical Proximity Switches

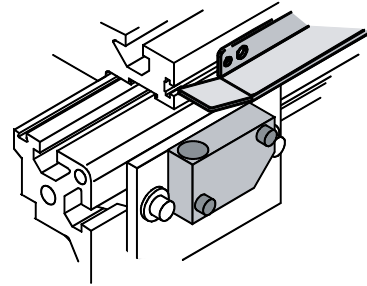

4-wire NPN switch with mounting hardware

Product	Part Number
HPLA (all models):	002-2440-03
HLE60-RB, HLE60-SR	002-1892-01
HLE100-RB, HLE100-SR	510-900010
HLE150-RB, HLE150-Z	510-900030

4-wire PNP switch with mounting hardware

Product	Part Number
HPLA (all models):	002-2440-01
HLE60-RB, HLE60-SR	002-1892-02
HLE100-RB, HLE100-SR	510-900020
HLE150-RB, HLE150-Z	510-900040

Inductive proximity switches are triggered by a standard tripping plate mounted to the side of the carriage. Available in both NPN and PNP 4-wire DC complementary outputs, the switches can be wired either NO or NC operation.

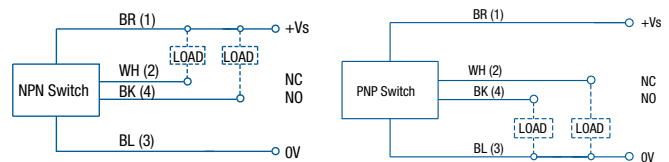

Sensing Distance	4 mm ± 10%
Voltage Supply	10-30 VDC
Switching Capacity	200 mA
Switching Response	2000 Hz
Current Consumption	<200 mA
Voltage Drop	<3 V
Protection Class	IP67
Operating Temperature	-25° C to 70° C (-13° F to 158° F)
Lead Termination	5 meter (200 in)
Reverse Polarity Protection	Yes
Short Circuit Protection	Yes

Cable Carriers

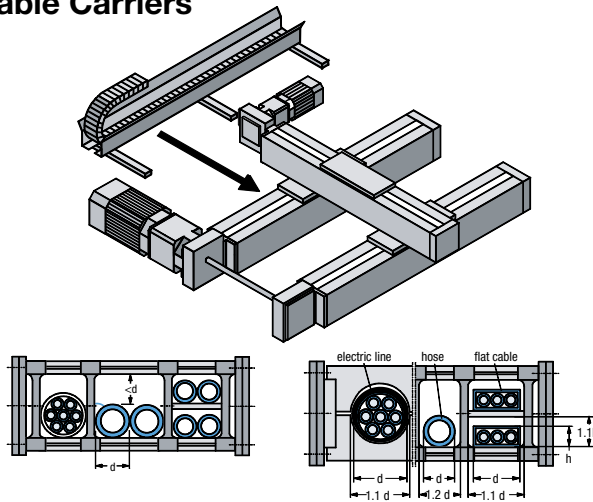

Typical Cross Sections

A cable carrier assembly is normally needed to transport cables to the carriage or custom payload. A complete cable carrier assembly includes the carrier, trough, end brackets, and mounting hardware. The cable carrier should be specifically matched to the linear actuator and other application requirements. Because of the extreme amount of cable flexing associated with high speed cable management, Parker uses only long life high-flex cables with its gantry systems. We recommend that all electric cables be approved for high speed cable carrier usage and that manufacturer's guidelines for bend radii are followed.

Cable Carrier Guidelines

Hose lines should be highly flexible and should only extend slightly under pressure. Weight should be distributed across the cable track as evenly as possible. Cables must not be twisted when routed in the cable carrier and should be routed next to one another with approximately 10% additional space.

Avoid laying several lines on top of each other and laying lines of different diameters directly next to one another. If multiple layers must be used, dividers should be inserted between each layer - should such circumstances arise, please contact a Parker application engineer. If there is no alternative to routing several lines beside each other without subdivisions, the clearance height within the carrier must be less than line diameter. This is the only way of preventing the cables from twisting. The supply cables must be able to move freely in the cable carrier - they must never be fastened or bundled together. Separating strips must always be inserted between flat cables routed in multiple layers.

Due to diversity of the requirements associated with high speed cable management systems, it is recommended that you contact your Parker applications engineer.

Toe Clamps

The toe clamps are used to rapidly install and fasten various combinations of linear actuators to each other; to a ParFrame™ structure; or to a mounting surface. Two clamps are required to fasten an HLE, HPLA, or HLEZ to a load attachment plate. The table at right shows the profiles for the various axis combinations.

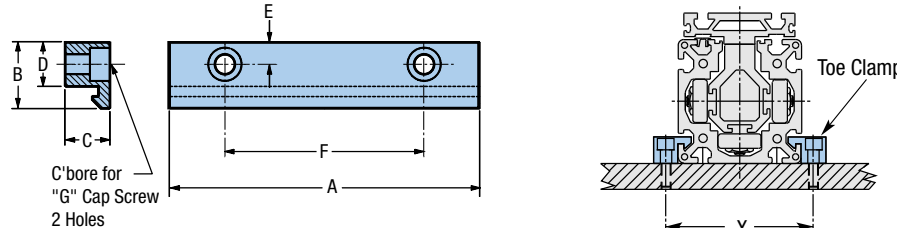
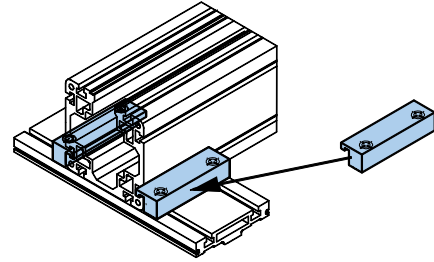

Belt Driven Tables

Dimensions

Used With	Part Number	A	B	C	D	E	F	G	X
HLE60-RB, HLE60-SR	000-7752-01	54	18	10	12	6	43	M5	70
HPLA080	500-000931	76	27	17	20	10	48	M5	100
HPLA080	500-000932	90	27	17	20	10	60	M8	100
HPLA080	500-000930	110	27	17	20	10	70	M8	100
HLE100-RB, HLE100-SR	500-000905	90	30	20	20	10	60	M6	120
HPLA120	500-000925	110	37.5	26	25	12.5	70	M8	145
HPLA180	500-000920	170	45	36	30	15	110	M10	210
HLE150-RB, HLE150-Z	500-000902	140	40	30	25	12	90	M8	176

Splice Plates

Splice Plates enable travels to be extended significantly beyond the standard range which is limited by extrusion length. Design concepts and factory installation expertise combine to produce perfectly spliced units which are easily recreated on site. The splice plate connection is only recommended for units with the carriage in the top or the bottom position.

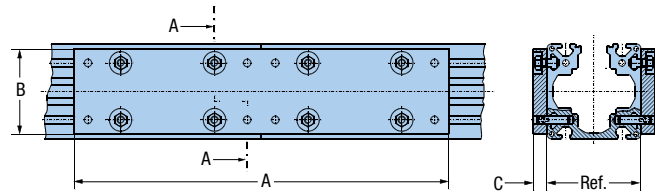

Dimensions

Model/Size	A	B	C	Ref.
HPLA080	300	70	15	80
HLE100-RB, HLE100-SR	400	90	15	100
HPLA120	400	110	15	120
HLE150-RB, HLE150-Z	500	130	15	150
HPLA180	500	165	20	180

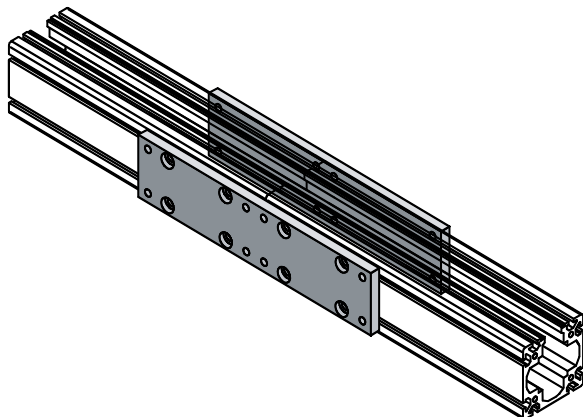

T-Nuts and T-Bolts

The T-nuts and bolts are used to fasten any element into the T-slots of the profile and to the upper side of the flange plate.

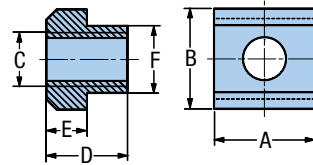

T-Nuts

Standard Part Number	Corrosion Resistant Part Number	Used With	Dimensions (mm)					
			A	B	C	D	E	F
100-2353-01	—	HLE60-RB, HLE60-SR	11	9	M5	3	—	—
131-700102	135-725390	HPLA080	10	10	M5	8	4	5.6
131-700147	—	HPLA080	20	10	M5	8	4	5.6
131-700103	135-725400	HLE100-RB, HLE100-SR	13	13	M6	10	6	—
131-700135	—	HPLA120, HLE150-RB, HLE150-Z	15	15	M6	12	6	10
131-700104	135-725402	HPLA120, HLE150-RB, HLE150-Z	15	15	M8	12	6	10
131-700141	—	HPLA120, HLE150-RB, HLE150-Z	30	15	M8	12	6	10
131-700112	135-725401	HPLA180	18	18	M6	14	7	12
131-700111	135-725420	HPLA180	35	18	M10	14	7	12

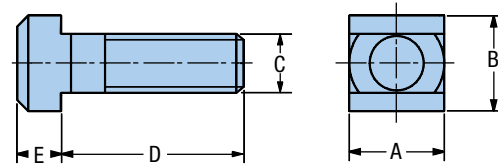

T-Bolts

Standard Part Number	Corrosion Resistant Part Number	Used With	Dimensions (mm)				
			A	B	C	D	E
131-700030	135-725430	HPLA080	10	10	M6	15	4
131-700031	—	HPLA080	10	10	M6	25	4
131-700032	—	HPLA080	10	10	M6	30	4
131-700001	—	HLE100-RB, HLE100-SR	13	13	M8	25	6
131-700002	135-725450	HLE100-RB, HLE100-SR	13	13	M8	32	6
131-700007	135-725459	HPLA120	15	15	M10	25	6
131-700008	135-725460	HPLA120, HLE150-RB, HLE150-Z	15	15	M10	32	6
131-700009	135-725465	HLE150-RB, HLE150-Z	15	15	M10	40	6
131-700016	135-725482	HPLA180	18	18	M12	25	7
131-700015	135-725480	HPLA180	18	18	M12	50	7

External Bumpers

External bumpers serve as adjustable hard stops. They are fitted to the grooves in the housing profile and are often utilized for restricting total travel.

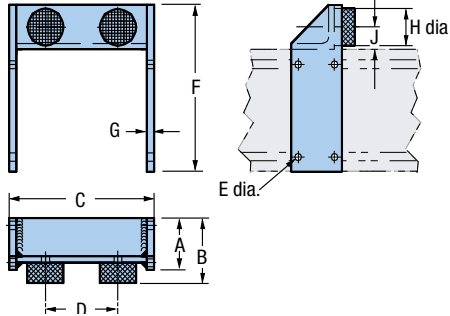
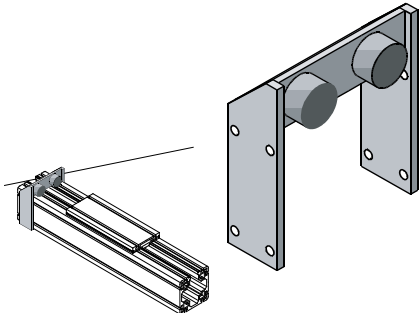

HPLA Series

Dimensions (mm)

Part Number	Used With	A	B	C	D	E	F	G	H	J
510-006497	HPLA080	30	45	90	56	5.5	91	5	15	11
510-007497	HPLA120	50	60	140	74	9	150	10	30	17
510-008497	HPLA150	70	88	200	100	11	225	10	50	30

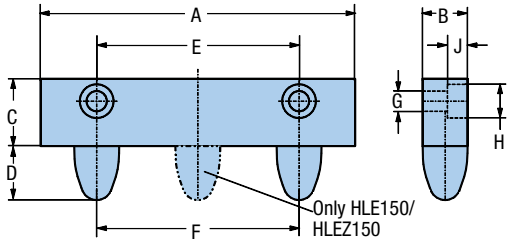
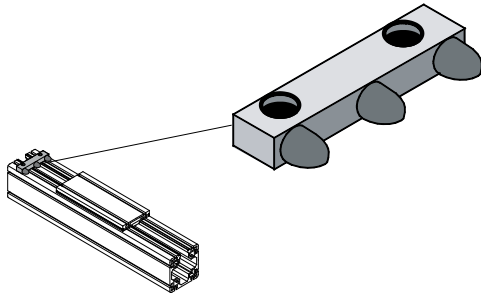

HLE Series

Dimensions (mm)

Part Number	Used With	A	B	C	D	E	F	G	H	J
510-300004	HLE100-RB, HLE100-SR	90	20	30	24	60	40	6.6	11	6.8
510-300005	HLE150-RB, HLE150-Z	140	20	30	24	90	90	6.6	11	9.0